

# C332

# OKI



## User's Guide



## PREFACE

Every effort has been made to ensure that the information in this document is complete, accurate, and up-to-date. The manufacturer assumes no responsibility for the results of errors beyond its control. The manufacturer also cannot guarantee that changes in software and equipment made by other manufacturers and referred to in this guide will not affect the applicability of the information in it. Mention of software products manufactured by other companies does not necessarily constitute endorsement by the manufacturer.

While all reasonable efforts have been made to make this document as accurate and helpful as possible, we make no warranty of any kind, expressed or implied, as to the accuracy or completeness of the information contained herein.

The most up-to-date drivers and manuals are available from:

**<http://www.oki.com/printing/>**

Copyright © 2016. All rights reserved.

OKI is a registered trademark of Oki Electric Industry Co., Ltd.

Energy Star is a trademark of the United States Environmental Protection Agency.

Microsoft, MS-DOS and Windows are registered trademarks of Microsoft Corporation.

Apple, Macintosh, Mac and Mac OS are registered trademarks of Apple Inc.

Other product names and brand names are registered trademarks or trademarks of their proprietors.



As an Energy Star Program Participant, the manufacturer has determined that this product meets the Energy Star guidelines for energy efficiency.



This product complies with the requirements of the Council Directives 2014/30/EU(EMC), 2014/35/EU(LVD),1999/5/EC (R&TTE), 2009/125/EC (ErP) and 2011/65/EU(RoHS), as amended where applicable, on the approximation of the laws of the member states relating to Electromagnetic Compatibility, Low Voltage, Radio & Telecommunications Terminal Equipment, Energy related Products and Restriction on the use of certain Hazardous Substances in electrical and electronic equipment.

The following cables were used to evaluate this product to achieve EMC directive 2014/30/EU compliance and configurations other than this may affect that compliance.

CABLE TYPE	LENGTH (METRE)	CORE	SHIELD
Power	1.8	×	×
USB	5.0	×	✓
LAN	7.0	×	×

## EMERGENCY FIRST AID

Take care with toner powder:

**If swallowed, give small amounts of cold water and seek medical attention. DO NOT attempt to induce vomiting.**



**If inhaled, move the person to an open area for fresh air. Seek medical attention.**

**If it gets into the eyes, flush with large amounts of water for at least 15 minutes keeping eyelids open. Seek medical attention.**

**Spillages should be treated with cold water and soap to help reduce risk of staining skin or clothing.**

## MANUFACTURER

Oki Data Corporation,  
4-11-22 Shibaura, Minato-ku,  
Tokyo 108-8551,  
Japan

## IMPORTER TO THE EU/AUTHORISED REPRESENTATIVE

Oki Europe Limited

Blays House  
Wick Road  
Egham  
Surrey, TW20 0HJ  
United Kingdom

For all sales, support and general enquiries contact your local distributor.

## ENVIRONMENTAL INFORMATION



# CONTENTS

<b>Preface</b> . . . . .	<b>2</b>
<b>Emergency first aid</b> . . . . .	<b>3</b>
<b>Manufacturer</b> . . . . .	<b>3</b>
<b>Importer to the EU/authorised representative</b> . . . . .	<b>3</b>
<b>Environmental information</b> . . . . .	<b>3</b>
<b>Contents</b> . . . . .	<b>4</b>
<b>Notes, cautions and warnings</b> . . . . .	<b>6</b>
<b>About this guide</b> . . . . .	<b>7</b>
Documentation suite . . . . .	7
On-line usage . . . . .	8
Printing pages . . . . .	8
<b>Getting Started</b> . . . . .	<b>9</b>
Overview . . . . .	9
Front view . . . . .	9
Rear view . . . . .	10
Changing the display language . . . . .	10
Switching on . . . . .	10
Switching off . . . . .	10
Energy saving settings . . . . .	11
Power saving mode . . . . .	11
Sleep mode . . . . .	11
Returning to standby mode . . . . .	11
<b>Paper recommendations</b> . . . . .	<b>12</b>
Cassette trays . . . . .	13
Multi purpose tray . . . . .	14
Output tray (face down) . . . . .	14
Rear output tray (face up) . . . . .	14
Duplex . . . . .	14
<b>Loading paper</b> . . . . .	<b>15</b>
Cassette trays . . . . .	15
Multi purpose tray . . . . .	18
<b>Operation</b> . . . . .	<b>19</b>
<b>Menu functions</b> . . . . .	<b>20</b>
<b>Operator panel</b> . . . . .	<b>20</b>
How to change the settings - user . . . . .	22
How to change the settings - administrator . . . . .	22
Menus . . . . .	23
Configuration . . . . .	23
Print Info . . . . .	25
Menus . . . . .	26
Admin Setup . . . . .	35
Network Setup . . . . .	36
USB Setup . . . . .	37
Print Setup . . . . .	37
Color Menu . . . . .	40
PS Setup . . . . .	41
PCL Setup . . . . .	42
XPS Setup . . . . .	43
IBM PPR Setup . . . . .	44
EPSON FX Setup . . . . .	45
Panel Setup . . . . .	46
Power Setup . . . . .	46

Tray Setup . . . . .	.46
Others Setup . . . . .	.47
Settings . . . . .	.48
Change Password . . . . .	.48
Print statistics . . . . .	.49
AirPrint . . . . .	.49
Google Cloud Print . . . . .	.50
Wireless Setting . . . . .	.51
Wireless (AP Mode) Setting . . . . .	.52
Boot Menu . . . . .	.52
<b>Maintenance . . . . .</b>	<b>.54</b>
Replacing consumable items . . . . .	.54
Toner cartridge replacement . . . . .	.54
Replacing the transfer belt unit . . . . .	.58
Fuser replacement . . . . .	.60
Cleaning . . . . .	.62
...the unit casing . . . . .	.62
...the LED head . . . . .	.62
<b>Installing upgrades . . . . .</b>	<b>.63</b>
Additional paper tray . . . . .	.63
Setting the driver device options . . . . .	.64
Wireless LAN Module . . . . .	.65
Precautions when using wireless LAN . . . . .	.65
Connecting via wireless LAN (Infrastructure mode) . . . . .	.65
Connecting via wireless LAN (AP mode) . . . . .	.67
<b>Troubleshooting . . . . .</b>	<b>.68</b>
Major printer components and paper path . . . . .	.68
Paper sensor error codes . . . . .	.69
Clearing paper jams . . . . .	.70
Dealing with unsatisfactory printing . . . . .	.75
<b>Before Machine Disposal . . . . .</b>	<b>.77</b>
<b>Specifications . . . . .</b>	<b>.78</b>
<b>Index . . . . .</b>	<b>.79</b>
<b>Oki contact details . . . . .</b>	<b>.80</b>

## NOTES, CAUTIONS AND WARNINGS

---

### NOTE

*A note provides additional information to supplement the main text.*

---

### CAUTION!

**A caution provides additional information which, if ignored, may result in equipment malfunction or damage.**

### WARNING!

**A warning provides additional information which, if ignored, may result in a risk of personal injury.**

For the protection of your product, and in order to ensure that you benefit from its full functionality, this model has been designed to operate only with genuine original toner cartridges. Any other toner cartridge may not operate at all, even if it is described as "compatible", and if it does work, your product's performance and print quality may be degraded.

**Use of non-genuine products may invalidate your warranty.**

Specifications subject to change without notice. All trademarks acknowledged.

## ABOUT THIS GUIDE

---

*NOTE*

*Images used in this manual may include optional features that your product does not have installed.*

---

### DOCUMENTATION SUITE

This guide is part of a suite of online and printed documentation provided to help you become familiar with your product and to make the best use of its many powerful features. The documentation is summarised below for reference and is found on the manuals DVD unless indicated otherwise:

- > **Installation Safety booklet:** provides information for safe use of your product.  
This is a paper document that is packaged with the product and should be read before setting up your machine.
- > **Set-up guide:** describes how to unpack, connect and turn on your product.  
This is a paper document that is packaged with the product.
- > **User's Guide:** helps you become familiar with your product and make the best use of its many features. Also included are guidelines for troubleshooting and maintenance to ensure that it performs at its best. Additionally, information is provided for adding optional accessories as your printing needs evolve.
- > **Network Guide:** helps you become familiar with the functionality of the built in network interface card.
- > **Printing Guide:** helps you become familiar with the many features of the driver software supplied with your product.
- > **Barcode Printing Guide:** helps you become familiar with your product's built in barcode printing feature.
- > **Installation Guides:** accompany consumable items and optional accessories to describe how to install them.  
These are paper documents that are packaged with the consumables and optional accessories.
- > **On-line Help:** on-line information accessible from the printer driver and utility software.

Depending on your OS, model or version, the description on this document may be different.

## ON-LINE USAGE

This guide is intended to be read on screen using Adobe Reader. Use the navigation and viewing tools provided in Adobe Reader.

There are many cross-references within this book, each highlighted as [blue text](#). When you click on a cross-reference the display will instantly jump to the part of the manual containing the referenced material.

By using the  button in Adobe Reader, you can navigate directly back to where you were before.

You can access specific information in two ways:

- > In the list of bookmarks down the left hand side of your screen, click on the topic of interest to jump to the required topic. (If the bookmarks are not available, use the ["Contents" on page 4.](#))
- > In the list of bookmarks, click on Index to jump to the Index. (If the bookmarks are not available, use the ["Contents" on page 4.](#)) Find the term of interest in the alphabetically arranged index and click on the associated page number to jump to the page containing the term.

## PRINTING PAGES

The whole manual, individual pages, or sections may be printed. The procedure is:

1. From the toolbar, select **File > Print** (or press the **Ctrl + P** keys).
2. Choose which pages you wish to print:
  - (a) **All pages**, (1), for the entire manual.
  - (b) **Current page**, (2), for the page at which you are looking.

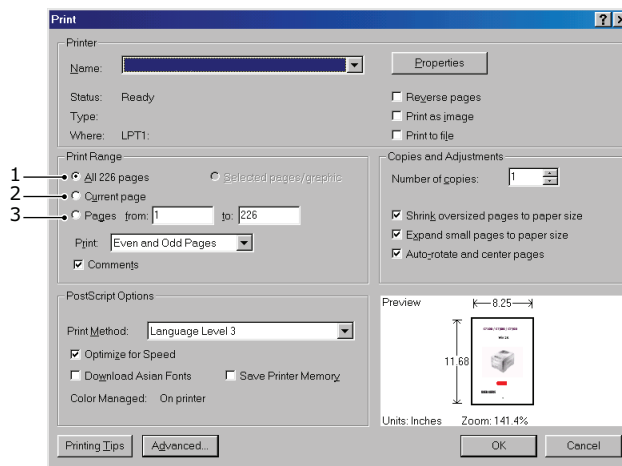

- (c) **Pages from and to**, (3), for the range of pages you specify by entering their page numbers.
- (d) Click **OK**.



# GETTING STARTED

## OVERVIEW

### FRONT VIEW

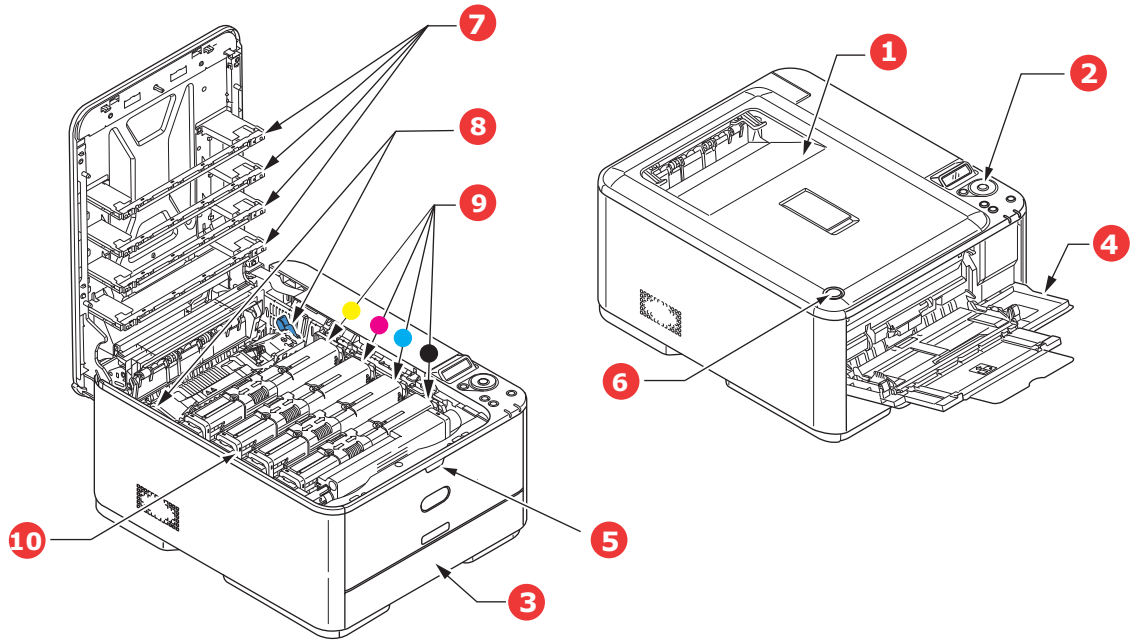

1. Output tray (face down stacker).  
Standard printed copy delivery point. Holds up to 150 sheets at 80g/m<sup>2</sup>.
2. Operator panel.  
Menu driven operator controls and LCD panel<sup>2</sup>.
3. Paper tray.  
Standard paper tray. Holds up to 250 sheets of 80g/m<sup>2</sup> paper.
4. Multi purpose tray.  
Used for feeding heavier paper stocks, envelopes and other special media. Also for manual feeding of single sheets when required.
  - a. The display language can be changed to show different languages. (see ["Changing the display language" on page 10](#)).
5. Multi-purpose tray release recess.
6. Output tray release button.
7. LED heads.
8. Fuser release levers.
9. Toner cartridges (C,M,Y,K).
10. ID unit.

## REAR VIEW

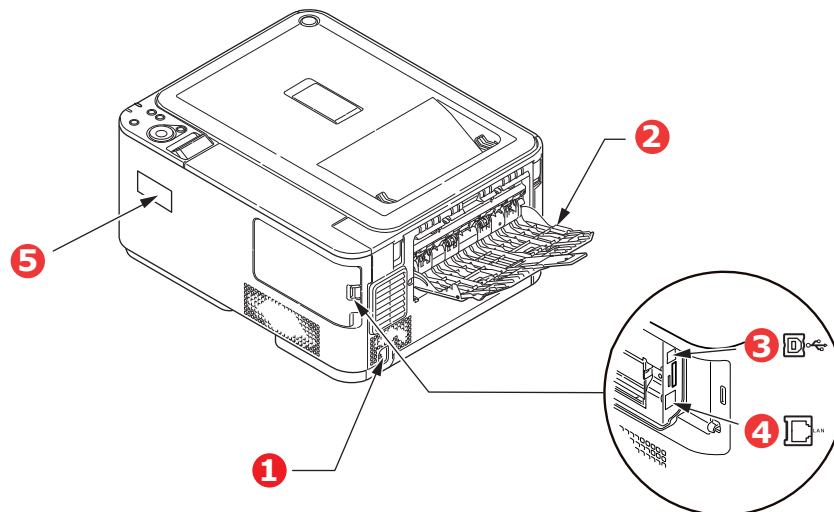

1. AC power socket.
  2. Rear output tray (face up stacker).
  3. USB interface.
  4. Network interface.<sup>a</sup>
  5. Wireless LAN I/F Cover.
- a. The Network Interface may have a protective "plug" which must be removed before connection can be made.

When the rear paper stacker is folded down paper exits the printer through the rear of the printer and is stacked here face up. This is mainly used for heavy print media. When used in conjunction with the multi purpose feed tray, the paper path through the printer is essentially straight. This avoids bending the paper around curves in the paper path and enables feeding of up to 220g/m<sup>2</sup> media.

## CHANGING THE DISPLAY LANGUAGE

The default language used by your machine for display messages is English. If required, this can be changed using the operator panel to display **ADMIN SETUP > OTHERS SETUP > LANGUAGE SETUP**.

## SWITCHING ON

1. Plug the power cable into the power socket of your machine.
2. Plug the power cable into the electric socket.
3. Press the power switch ON.

## SWITCHING OFF

Hold down the power switch for approximately one second.

---

### NOTE

*A message displays on the LCD screen and power switch indicator blinks, then the printer switches OFF automatically.*

---

## ENERGY SAVING SETTINGS

### POWER SAVING MODE

If you do not use the machine for a while, it will enter the power saving mode to control the power consumption of the device. To cancel or initiate power saving mode, press the **POWER SAVE** button on the control panel. The **POWER SAVE** button illuminates while in Power Save Mode.

---

*NOTE*

*By default, the time interval to enter power saving mode is set to 1 minute. You can change the time interval by pressing the **MENU** buttons on the control panel. Then select **MENUS > SYSTEM ADJUST > POW SAVE TIME**.*

---

### SLEEP MODE

Your machine transitions from power saving mode to sleep mode after a set period of time. In sleep mode the power consumption of the device is minimal. The **POWER SAVE** button blinks while in sleep mode.

---

*NOTE*

- > *The machine will not enter sleep mode if an error occurs and the machine requires attention.*
  - > *By default, the time interval to enter sleep mode is set to 15 minutes. You can change the time interval by pressing the **MENU** buttons on the control panel. Then select **MENUS > SYSTEM ADJUST > SLEEP TIME**.*
  - > *It will automatically switch from Sleep Mode to Power Save Mode. In a network environment with a large number of packets flows, your computer may respond by automatically switching from Sleep mode to Power Save Mode. After a period of time has elapsed, the computer will automatically enter into Sleep Mode.*
- 

### RETURNING TO STANDBY MODE

To return the machine to standby mode from power save or sleep mode, press the **POWER SAVE** button on the control panel.

---

*NOTE*

*When your machine receives a print job, it automatically returns to standby mode.*

---

## PAPER RECOMMENDATIONS

Your printer will handle a variety of print media, including a range of paper weights and sizes, labels and envelopes. This section provides general advice on choice of media, and explains how to use each type.

The best performance will be obtained when using standard 75~90g/m<sup>2</sup> paper designed for use in copiers and laser printers.

Use of heavily embossed or very rough textured paper is not recommended.

**Pre-printed stationery** can be used, but the ink must not offset when exposed to the high fuser temperatures used in the printing process.

### Envelopes

#### CAUTION!

**Envelopes should be free from twist, curl or other deformations. They should also be of the rectangular flap type, with glue that remains intact when subjected to hot roll pressure fusing used in this type of printer. Window envelopes are not suitable.**

### Labels

#### CAUTION!

**Labels should also be of the type recommended for use in copiers and laser printers, in which the base carrier page is entirely covered by labels. Other types of label stock may damage the printer due to the labels peeling off during the printing process.**

## CASSETTE TRAYS

SIZE	DIMENSIONS	WEIGHT (G/M <sup>2</sup> )	
A6 <sup>a</sup>	105 x 148mm	Light	64 - 74g/m <sup>2</sup>
A5	148 x 210mm	Medium Light	75 - 82g/m <sup>2</sup>
B5	182 x 257mm	Medium	83 - 104g/m <sup>2</sup>
B6 <sup>a</sup>	128 x 182mm	Heavy	105 - 120g/m <sup>2</sup>
B6 half	64 x 182mm		
Executive	184.2 x 266.7mm	Ultra heavy1	121 - 176g/m <sup>2</sup>
A4	210 x 297mm	Ultra heavy2	177 - 220g/m <sup>2</sup>
Letter	215.9 x 279.4mm	Tray 1/2:	64 - 176g/m <sup>2</sup>
Legal 13in.	216 x 330mm	MP tray:	64 - 220g/m <sup>2</sup>
Legal 13.5in.	216 x 343mm	Duplex:	64 - 176g/m <sup>2</sup>
Legal 14in.	216 x 356mm		
Statement <sup>a</sup>	139.7 x 216mm		
8.5in.SQ	216 x 216mm		
Folio	210 x 330mm		
Custom			
COM-9 Envelope <sup>b</sup>	98.4 x 225.4mm		
COM-10 Envelope <sup>b</sup>	104.8 x 241.3mm		
Monarch Envelope <sup>b</sup>	98.4 x 190.5mm		
DL Envelope <sup>b</sup>	110 x 220mm		
C5 Envelope <sup>b</sup>	162 x 229mm		
4 x 6inch	(4 x 6)		
5 x 7inch	(5 x 7)		
Index Card <sup>b</sup>	(3 x 5)		

a. A6, B6 and Statement printing from Tray 1 or the MP tray only.

b. This paper size can be printed from the MP Tray only.

If you have identical paper stock loaded in another tray (2nd tray if you have one, or multi purpose tray) you have the printer automatically switch to the other tray when the current tray runs out of paper. When printing from Windows applications, this function is enabled in the driver settings. When printing from other systems, this function is enabled in the Print Menu. (See ["AUTO TRAY SWITCH" on page 29.](#))

## **MULTI PURPOSE TRAY**

The multi purpose tray can handle the same sizes as the cassette trays but in weights up to 220g/m<sup>2</sup>. For very heavy paper stock use rear output tray (face up). This ensures that the paper path through the printer is almost straight.

The multi purpose tray can feed paper widths from 64mm to 216mm and lengths from 127mm to 1321mm (banner printing).

For paper lengths exceeding 356mm (Legal 14in.) use paper stock between 90g/m<sup>2</sup> and 128g/m<sup>2</sup> and rear output tray (face up).

Use the multi purpose tray for printing on envelopes. Up to 10 envelopes can be loaded at one time, subject to a maximum stacking depth of 10mm.

## **OUTPUT TRAY (FACE DOWN)**

Output tray on the top of the printer can hold up to 150 sheets of 80g/m<sup>2</sup> standard paper, and can handle paper stocks up to 176g/m<sup>2</sup>.

Pages printed in reading order (page 1 first) will be sorted in reading order (last page on top, facing down).

The number of sheets that can be stacked on the face down staker may vary depending on environment.

## **REAR OUTPUT TRAY (FACE UP)**

Rear output tray at the rear of the printer should be opened and the tray extension pulled out when required for use. In this condition paper will exit via this path, regardless of driver settings.

Rear output tray can hold up to 100 sheets of 80g/m<sup>2</sup> standard paper, and can handle stocks up to 220g/m<sup>2</sup>.

Always use this staker and the multi purpose feeder for paper stocks heavier than 176g/m<sup>2</sup>.

## **DUPLEX**

Automatic two-sided printing on the same range of paper sizes as tray 2 (i.e. all cassette sizes except A6), using paper stocks from 64 - 176g/m<sup>2</sup>.

# LOADING PAPER

## CASSETTE TRAYS

1. Remove the paper tray from the printer.

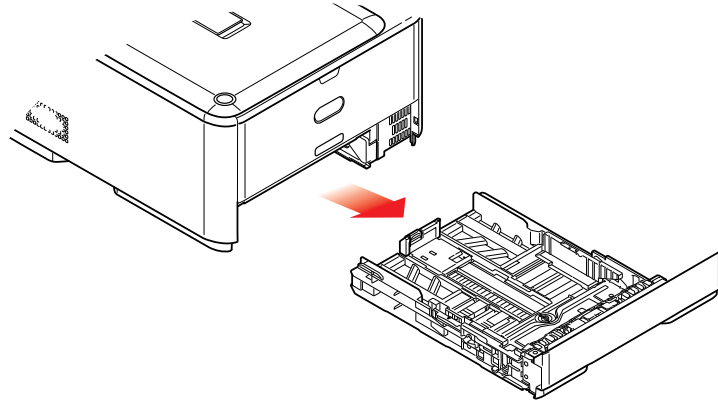

2. Fan the paper to be loaded at the edges (1) and in the middle (2) to ensure that all sheets are properly separated, then tap the edges of the stack on a flat surface to make it flush again (3).

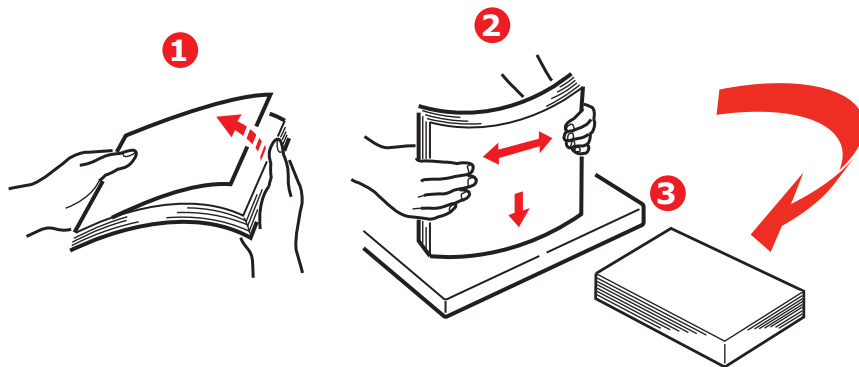

- 3.** Load paper (letter headed paper face down and top edge towards the front of the printer), as shown.

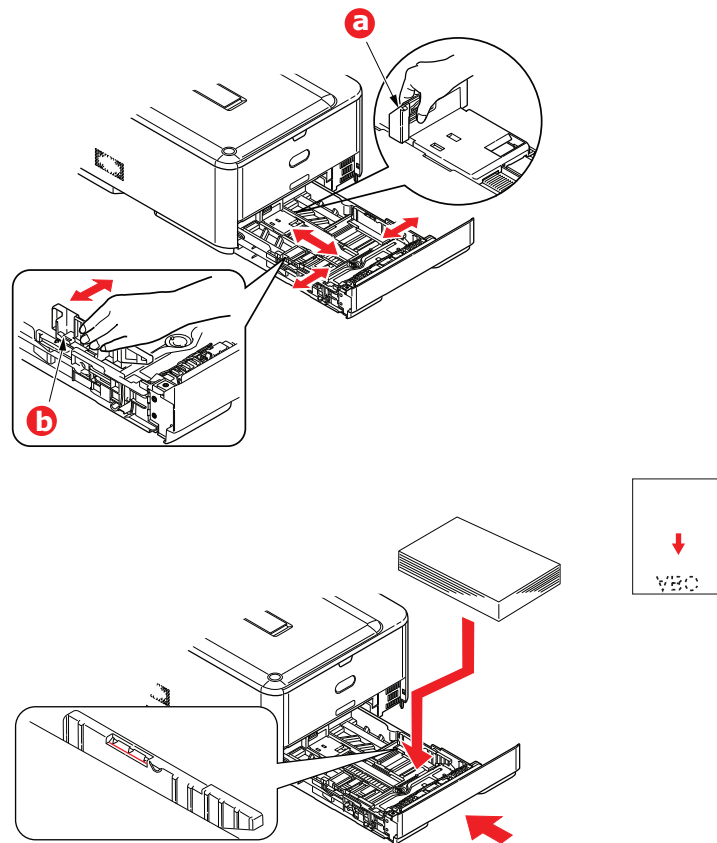

- 4.** Adjust the rear stopper (a) and paper guides (b) to the size of paper being used.  
**5.** Close the paper tray gently.

To prevent paper jams:

- > Do not leave space between the paper and the guides and rear stopper.
- > Do not overfill the paper tray. Capacity depends on the type of paper stock.
- > Do not load damaged paper.
- > Do not load paper of different sizes or types at the same time.
- > Close the paper tray gently.



- > Do not pull the paper tray out during printing (except as described below for the 2nd tray).

---

**NOTE**

- > *If you have two trays and you are printing from the 1st (upper) tray, you can pull out the 2nd (lower) tray during printing to reload it. However, if you are printing from the 2nd (lower) tray, do not pull out the 1st (upper) tray. This will cause a paper jam.*
  - > *For face down printing, make sure rear output tray (a) is closed (the paper exits from the top of the printer). Stacking capacity is approximately 150 sheets, depending on paper weight.*
  - > *For face up printing, make sure rear output tray (a) is open and the paper support (b) is extended. Paper is stacked in reverse order and tray capacity is approximately 100 sheets, depending on paper weight.*
  - > *Always use the face up (rear) stacker for heavy paper (card stock, etc.).*
- 

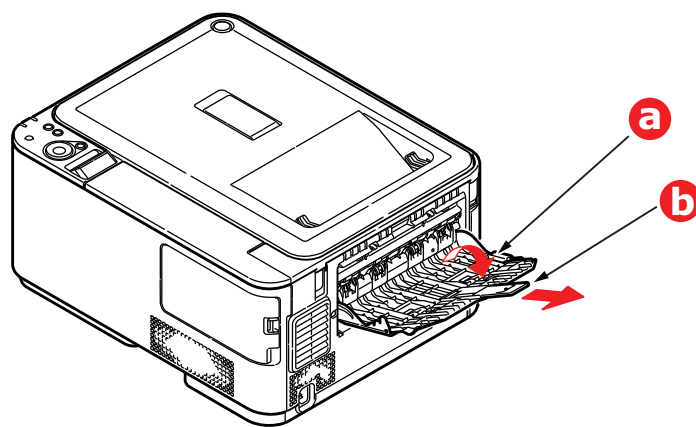

**CAUTION!**

**Do not open or close the rear paper exit while printing as it may result in a paper jam.**

## MULTI PURPOSE TRAY

1. Open the multi purpose tray (a).
2. Fold out the paper supports (b).

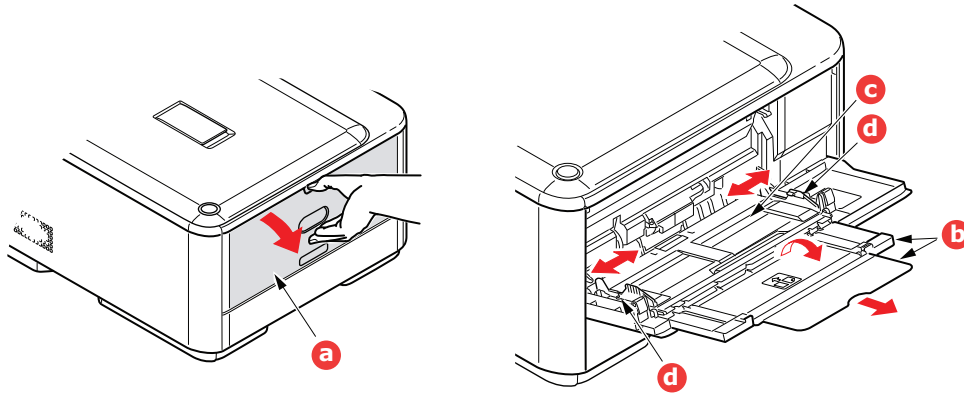

3. Press gently down on the paper platform (c) to ensure it is latched down.
4. Load the paper and adjust the paper guides (d) to the size of paper being used.
  - > For single-sided printing on headed paper load the paper into the multi purpose tray with pre-printed side up and top edge into the printer.
  - > For two-sided (duplex) printing on headed paper load the paper with pre-printed side down and top edge away from the printer.
  - > Envelopes should be loaded face up with top edge to the left and short edge into the printer. Do not select duplex printing on envelopes.
  - > Do not exceed the paper capacity of about 100 sheets or 10 envelopes. Maximum stacking depth is 10mm.
5. Press the tray latch button inwards to release the paper platform, so that the paper is lifted and gripped in place.
6. Set the correct paper size for the multi purpose tray in the Media Menu.

---

### NOTE

- > Do not press the paper from the top or pull the paper by holding it while the printer is printing from the MP tray. If you want to stop printing, open the output tray.
  - > For instructions on how to remove the paper, refer to "[Clearing paper jams](#)" on page 70.
-

## **OPERATION**

For full details of how to use the machine and any optional accessories to print jobs efficiently and effectively, please refer to the Printing Guide and the Barcode Guide.

## MENU FUNCTIONS

This section lists the menus accessed via the controls on the printer's operator panel and displayed in the LCD window.

### OPERATOR PANEL

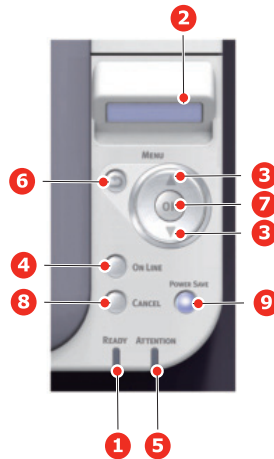

<b>1. READY LED</b>	<b>ON:</b> Ready to receive data. <b>BLINKING:</b> Processing data. <b>OFF:</b> Offline.	<b>2. DISPLAY</b>	Displays the printer status and any error messages.
<b>3. MENU Buttons</b>	In the <b>ONLINE</b> or <b>OFFLINE</b> mode: enters the Menu mode. In the <b>Menu</b> mode: forwards or reverses the menu item displayed. Press for 2 secs. or longer to fast forward or reverse.	<b>4. ON LINE Button</b>	Switches between ONLINE and OFFLINE. Exits the menu and goes ONLINE when pressed in the Menu mode. Forces printing on the paper currently loaded when pressed with "WRONG PAPER" or "WRONG PAPER SIZE" displayed.
<b>5. ATTENTION LED</b>	<b>ON:</b> A warning occurs. Printing may be possible (e.g low toner). <b>BLINKING:</b> An error occurs. Printing not possible (e.g. toner empty). <b>OFF:</b> Normal condition.	<b>6. BACK Button</b>	Returns to the previous higher level menu item.

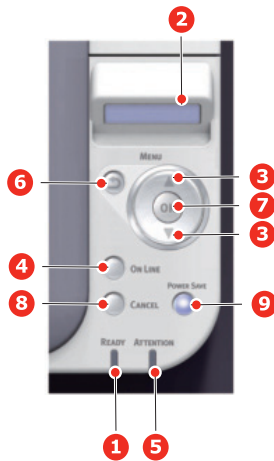

<p><b>7. OK Button</b></p>	<p>In the Menu mode: determines the setting selected.</p>	<p><b>8. CANCEL Button</b></p>	<p>Deletes the data being printed or received when pressed for two seconds or longer.</p> <p>Deletes the data when pressed for two seconds or longer with WRONG PAPER SIZE, RUN OUT OF PAPER, TRAY 1 IS OPEN, or TRAY 1 IS NOT FOUND is displayed.</p> <p>Exits the menu and goes ONLINE when pressed in the Menu mode.</p>
<p><b>9. POWER SAVE Button &amp; LED</b></p>	<p>Pressing this button switches the machine into power save mode or wakes the machine up from power save mode.</p> <p><b>ON</b>: Power save state.</p> <p><b>BLINKING</b>: Sleep state.</p> <p><b>OFF</b>: When it is not sleep or power save, either.</p>		

## HOW TO CHANGE THE SETTINGS - USER

It should be noted that many of these settings can be, and often are, overridden by settings in the Windows printer drivers. However, several of the driver settings can be left at "Printer Setting", which will then default to the settings entered in these printer menus.

Where applicable, factory default settings are shown in bold type in the following tables.

In the normal operating condition, known as "standby," the printer's LCD window will show "ONLINE." In this condition, to enter the menu system, press the **up** and **down** Menu buttons on the operator panel to move up and down through the list of menus until the menu you wish to view is displayed. Then proceed as follows:

1. Use the **up** and **down** MENU buttons on the control panel to scroll through the menus. When the item you want to change is displayed, press **OK** to view the sub-menu for that item.
2. Use the **up** and **down** MENU buttons to move up and down through the sub-menu items. When the item you want to change is displayed press **OK** to display the setting.
3. Use the **up** and **down** MENU buttons to move up and down through the available settings for the sub-menu item. When the item you want to change is displayed press **OK** to display the setting. An asterisk (\*) will appear next to the setting, indicating that this setting is currently in effect.
4. Do one of the following:
  - > Press **BACK** again to move up to the list of menus;
  - or...
  - > Press **ON LINE** or **CANCEL** to exit from the menu system and return to standby.

## HOW TO CHANGE THE SETTINGS - ADMINISTRATOR

You can set whether to **ENABLE** or **DISABLE** each category in the user menu.

Disabled categories are not displayed in the User's menu. Only a system administrator can change these settings.

1. Press **up** or **down** on the operator panel to display **ADMIN SETUP**.
2. Press the **OK** button.
3. At the Enter Password prompt, enter the Admin password:
  - (a) Using the **up** and **down** MENU buttons, scroll to the required letter/digit.
  - (b) Press the **OK** button to input and move to the next letter/digit.
  - (c) Repeat steps (a) and (b) until all letters/digits are entered.

**Enter your 6 to 12 digit password.**

(The default password is 999999).
4. Press the **OK** button.
5. Press the **up** or **down** MENU button until the "category" you want to change is displayed.
6. Press the **OK** button.
7. Press the **up** or **down** MENU button until the "item" you want to change is displayed.
8. Press the **OK** button.
9. Using the **up** or **down** MENU button, identify the parameter as required.
10. Press the **OK** button to enter an asterisk (\*) on the right side of the setting selected.

11. Press the **ON LINE** button to switch to online. The machine will automatically re-boot.

## MENUS

*NOTE*

*This guide is written to cover a number of models and as such may reference menu items or features that your machine does not have installed or does not support.*

## CONFIGURATION

ITEM		EXPLANATION	
TRAY COUNT	MP TRAY	The total number of pages fed from MP tray.	
	TRAY1	The total number of pages fed from tray 1.	
	TRAY2	The total number of pages fed from tray 2.	
SUPPLIES LIFE	DRUM UNIT LIFE	Percentage of image drum unit life remaining.	
	BELT LIFE	Percentage of belt life remaining.	
	FUSER LIFE	Percentage of fuser life remaining.	
	K TONER	K toner residual quantity.	
	C TONER	C toner residual quantity.	
	M TONER	M toner residual quantity.	
	Y TONER	Y toner residual quantity.	
NETWORK	NETWORK INFO	PRINTER NAME	Displays "Printer Name" (a printer name used in DNS or Network PnP) of the network with a wire.
		SHORT NAME	Displays "Short Printer Name" (a printer name used as NetBEUI Computer Name) of the network with a wire.
		ENABLING DEFAULT GATEWAY*	Displays the valid default gateway.
		WIRED	Displays the status ( <b>ENABLE/DISABLE</b> ) of the wired LAN.
		IPV4 ADDRESS	Current assigned IP address. To change, press OK and use <b>MENU</b> buttons to increment 1st octet, then press <b>OK</b> again to move on to next octet. When 4th octet has been set, press <b>OK</b> again to register new address.
		SUBNET MASK	Current assigned subnet mask. To change, proceed as above.
		GATEWAY ADDRESS	Current assigned gateway address. To change, proceed as above.
		MAC ADDRESS	Displays the MAC address of the network with a wire.
		NETWORK VERSION	Displays the version of F/W of the network with a wire.
		WEB VERSION	Displays the version of WebPage of the network with a wire.
		IPV6 LOCAL	Displays the local IPv6 address. This menu is not displayed when <b>DISABLE</b> is selected for <b>ADMIN SETUP &gt; NETWORK SETUP &gt; TCP/IP</b> .

\*: If the optional Wireless LAN Module is fitted.

ITEM		EXPLANATION	
NETWORK (cont.)	NETWORK INFO (cont.)	IPV6 STATELESS	Displays the IPv6 Address (Stateless Address) of the network.
		IPV6 STATEFUL	Displays the IPv6 Address (Stateful Address) of the network.
	WIRELESS (INFRASTRUCTURE) INFO*	FW VERSION	Displays the version of Wireless LAN Firmware.
		WIRELESS (INFRASTRUCTURE)	Displays the status ( <b>ENABLE/DISABLE</b> ) of the wireless LAN (Infrastructure mode).
		SSID	SSID of connection
		SECURITY	Displays the security type of wireless LAN.
		STATE	Displays the state of wireless LAN.
		BAND	Displays the using band of wireless LAN.
		CHANNEL	Display the using channel of wireless LAN.
		RSSI	Display the RSSI by percent.
		IPV4 ADDRESS	Displays the IPv4 Address of the network.
		SUBNET MASK	Displays the Subnet Mask of the network.
		GATEWAY ADDRESS	Displays the Gateway Address of the network.
		MAC ADDRESS	Displays the MAC Address of the printer.
		IPV6 LOCAL	Displays the IPv6 Address (Local) of the network.
		IPV6 STATELESS	Displays the IPv6 Address (Stateless Address) of the network.
		IPV6 STATEFUL	Displays the IPv6 Address (Stateful Address) of the network.
		WIRELESS (AP MODE) INFO*	WIRELESS (AP MODE)
	SSID		Displays the SSID of the connection destination.
	PASSWORD		Appears when <b>AP MODE USER SETTING</b> is set to <b>ENABLE</b> .
	CONNECTED DEVICES		Displays the number of connected devices.
	IPV4 ADDRESS		Displays the IPv4 address.
	SYSTEM	SERIAL NUMBER	Displays the serial number of the printer.
ASSET NUMBER		Displays the Asset Number.	
LOT NUMBER		Displays the Lot Number.	
FW VERSION		Displays the version number of Firmware.	
CU VERSION		Displays the version number of CU (Control Unit) firmware.	
PU VERSION		Displays the version number of PU (Print Unit) firmware.	
RAM		Displays the total size of all the RAM installed in the printer.	
FLASH MEMORY		Displays the total size of all the Flash Memory installed in the printer.	

\*: If the optional Wireless LAN Module is fitted.



## PRINT INFO

This menu provides a quick method of listing various items stored within the printer.

ITEM	EXPLANATION
CONFIGURATION	Prints complete menu listing with current settings shown.
NETWORK	Prints Network configuration information.
DEMO PAGE	Prints demonstration page containing graphics and text in color and monochrome.
PRINT FILE LIST	Prints a job file list.
PRINT PSE FONT	Prints a font list of installed PostScript.
PRINT PCL FONT	Prints a font list of installed PCL emulation and PCL barcode.
PRINT PPR FONT	Prints a font list of IBMPPR.
PRINT FX FONT	Prints a font list of EPSON FX.
USAGE REPORT	Prints the total of JobLog.
SUPPLIES REPORT	Prints the supplies report.
PRINT ERROR LOG	Prints an error log.
COLOR TUNING	Prints the pattern for the user to adjust TRC.
COLOR PROF LIST	Prints a list of stored color profiles.
JOB LOG	Prints the Job history.

## MENUS

ITEM		SETTINGS	EXPLANATION	
TRAY CONFIG	MP TRAY CONFIG	PAPERSIZE	<p>A4 A5 A6 B5 B6 B6 Half LEGAL14 LEGAL13.5 LEGAL13 LETTER EXECUTIVE STATEMENT 8.5"SQ Folio 16K(184x260mm) 16K(195x270mm) 16K(197x273mm) CUSTOM INDEXCARD 4x6 INCH 5x7 INCH COM-9 ENVELOPE COM-10 ENVELOPE MONARCH ENV DL ENVELOPE C5 ENVELOPE HAGAKI OUFUKUHAGAKI NAGAGATA #3 NAGAGATA #4 YOUGATA #4</p>	<p>Selects the size of paper to be fed from the multi purpose tray. For <b>CUSTOM</b> setting see <b>X DIMENSION</b> and <b>Y DIMENSION</b>.</p>
		X DIMENSION	<p>64 MILLIMETER ~ 210 MILLIMETER ~ 216 MILLIMETER</p>	<p>Specifies paper width of custom paper as a default value. Sets a paper size at right angles to the paper run direction.</p>
		Y DOMENSION	<p>127 MILLIMETER ~ 279 MILLIMETER ~ 297 MILLIMETER ~ 356 MILLIMETER ~ 1321 MILLIMETER</p>	<p>Specifies paper length of custom paper as a default value. Sets a paper size in the same direction as the paper run direction.</p>

ITEM		SETTINGS	EXPLANATION	
TRAY CONFIG (cont.)	MP TRAY CONFIG (cont.)	MEDIATYPE	<p><b>PLAIN</b></p> <p>LETTERHEAD</p> <p>LABELS</p> <p>BOND</p> <p>RECYCLED</p> <p>CARD STOCK</p> <p>ROUGH</p> <p>ENVELOPE</p> <p>GLOSSY</p> <p>USERTYPE1</p> <p>USERTYPE2</p> <p>USERTYPE3</p> <p>USERTYPE4</p> <p>USERTYPE5</p>	<p>Selects the type of media to be fed from the multi purpose tray so that the printer can adjust its internal parameters to better accommodate the selected type of media.</p> <p>Note: USERTYPEn are displayed only if registered in the host PC/Server.</p>
		MEDIAWEIGHT	<p>LIGHT</p> <p>MEDIUM LIGHT</p> <p><b>MEDIUM</b></p> <p>HEAVY</p> <p>ULTRA HEAVY1</p> <p>ULTRA HEAVY2</p>	<p>Selects the media weight to be fed from the multi purpose tray.</p>
		TRAY USAGE	<p>WHEN MISMATCHING</p> <p><b>DO NOT USE</b></p>	<p>If a document to be printed demands a paper size not installed in the selected tray, the printer can automatically feed from the multi purpose tray instead.</p> <p>If this function is not enabled, the printer will stop and request the correct size of paper to be loaded.</p>
TRAY1 CONFIG	PAPERSIZE	<p>A4</p> <p>A5</p> <p>A6</p> <p>B5</p> <p>B6</p> <p>LEGAL14</p> <p>LEGAL13.5</p> <p>LEGAL13</p> <p>LETTER</p> <p>EXECUTIVE</p> <p>STATEMENT</p> <p>8.5"SQ</p> <p>Folio</p> <p>16K(184x260mm)</p> <p>16K(195x270mm)</p> <p>16K(197x273mm)</p> <p>CUSTOM</p> <p>HAGAKI</p>	<p>Selects the size of paper loaded in Tray 1 (upper tray if both trays installed).</p> <p>For <b>CUSTOM</b> setting see <b>X DIMENSION</b> and <b>Y DIMENSION</b>.</p>	
		X DIMENSION	<p>100 MILLIMETER</p> <p>~</p> <p>210 MILLIMETER</p> <p>~</p> <p>216 MILLIMETER</p>	<p>Specifies paper width of custom paper as a default value.</p> <p>Sets a paper size at right angles to the paper run direction.</p>

ITEM		SETTINGS	EXPLANATION	
TRAY CONFIG (cont.)	TRAY1 CONFIG (cont.)	Y DIMENSION	148 MILLIMETER ~ 279 MILLIMETER ~ 297 MILLIMETER ~ 356 MILLIMETER	Specifies paper length of custom paper as a default value.  Sets a paper size in the same direction as the paper run direction.
		MEDIATYPE	<b>PLAIN</b> LETTERHEAD BOND RECYCLED CARD STOCK ROUGH GLOSSY USERTYPE1 USERTYPE2 USERTYPE3 USERTYPE4 USERTYPE5	Selects the type of media loaded in this tray. This will help the printer to adjust its internal operating parameters, such as engine speed and fusing temperature, to better accommodate the media to be fed.  For example, letterhead may benefit from a slightly lower fusing temperature to ensure that its ink does not offset.  Note: USERTYPE <sub>n</sub> are displayed only if registered in the host PC/Server.
		MEDIAWEIGHT	LIGHT MEDIUM LIGHT <b>MEDIUM</b> HEAVY ULTRA HEAVY1	Adjusts the printer for the weight of paper stock loaded in this tray.
	TRAY2 CONFIG	PAPERSIZE	A4 A5 B5 LEGAL14 LEGAL13.5 LEGAL13 LETTER EXECUTIVE 8.5"SQ Folio 16K(184x260mm) 16K(195x270mm) 16K(197x273mm) CUSTOM	Selects the size of paper loaded in Tray 2 (lower) if installed. For <b>CUSTOM</b> setting see <b>X DIMENSION</b> and <b>Y DIMENSION</b> .
		X DIMENSION	148 MILLIMETER ~ 210 MILLIMETER ~ 216 MILLIMETER	Specifies paper width of Custom paper as a default value.  Sets a paper size at right angles to the paper run direction.

ITEM		SETTINGS	EXPLANATION	
TRAY CONFIG (cont.)	TRAY2 CONFIG (cont.)	Y DOMENSION	210 MILLIMETER ~ 279 MILLIMETER ~ 297 MILLIMETER ~ 356 MILLIMETER	Specifies paper length of Custom paper as a default value.  Sets a paper size in the same direction as the paper run direction.
		MEDIATYPE	<b>PLAIN</b> LETTERHEAD BOND RECYCLED CARD STOCK ROUGH GLOSSY USERTYPE1 USERTYPE2 USERTYPE3 USERTYPE4 USERTYPE5	Selects the type of media loaded in this tray (if installed). This will help the printer to adjust its internal operating parameters, such as engine speed and fusing temperature, to better accommodate the media to be fed.  For example, letterhead may benefit from a slightly lower fusing temperature to ensure that its ink does not offset.  Note: USERTYPEn are displayed only if registered in the host PC/Server.
		MEDIAWEIGHT	LIGHT MEDIUM LIGHT <b>MEDIUM</b> HEAVY ULTRA HEAVY1	Adjusts the printer for the weight of paper stock loaded in this tray (if installed).
	PAPERFEED		MP TRAY <b>TRAY1</b> TRAY2	Selects the default tray for paper feed, Tray 1 (upper), Tray 2 (lower, if installed) or MP tray (multi purpose tray).
	AUTO TRAY SWITCH		<b>ON</b> OFF	If two trays contain identical paper, the printer can switch to an alternative source when the current tray runs out in the middle of a print job.
	TRAY SEQUENCE		<b>DOWN</b> UP PAPER FEED TRAY	Determines tray sequence order when automatically switching.
	DUPLEX LAST PAGE		<b>SKIP BLANK PAGE</b> ALWAYS PRINT	When <b>SKIP BLANK PAGE</b> is selected and a print job has an odd number of pages, the final page will be printed as Simplex.  When <b>ALWAYS PRINT</b> is selected and the print job contains an odd number of pages, the final page will be printed as Duplex.
	STSTEM ADJUST	POW SAVE TIME	<b>1 MIN</b> 2 MIN 3 MIN 4 MIN 5 MIN 10 MIN 15 MIN 30 MIN 60 MIN	Adjusts the idling time before the printer automatically switches into power saving mode. In this mode power consumption is reduced to a low level required to just keep the printer operating and ready to receive data.  When a job is sent the printer will require a warm-up time of up to 1 minute before printing can begin.

ITEM		SETTINGS	EXPLANATION
STSTEM ADJUST (cont.)	SLEEP TIME	1 MIN 2 MIN 3 MIN 4 MIN 5 MIN 10 MIN <b>15 MIN</b> 30 MIN 60 MIN	Adjusts the power saving time before the printer automatically switches into sleep mode.
	AUTO PW OFF TIME	1 HOURS 2 HOURS 3 HOURS <b>4 HOURS</b> 8 HOURS 12 HOURS 18 HOURS 24 HOURS	Sets the time to switch from idle state to Off mode.
	SILENT MODE	<b>ON</b> OFF	Specifies a print preparation operation when entering standby status from Sleep mode. <b>ON:</b> It is quiet as there is no print preparation. <b>OFF:</b> There is a rotation noise of the image to perform print preparation but you can start first printing early.
	ECO MODE	<b>ON</b> OFF	<b>ON:</b> Printing starts even before the temperature of the fuser reaches the prescribed degrees, if the job is small. <b>OFF:</b> Printing starts after the temperature of the fuser reaches the prescribed degrees.
	CLRABLE WARINING	<b>ONLINE</b> JOB	When <b>ONLINE</b> , non-critical warnings, such as requests for a different paper size, can be cleared by pressing the <b>ON LINE</b> button. When set to <b>JOB</b> , they are cleared when the print job resumes.
	AUTO CONTINUE	ON <b>OFF</b>	Determines whether or not the printer will automatically recover from a memory overflow condition.
	MANUAL TIMEOUT	OFF 30 SEC <b>60 SEC</b>	Specifies how many seconds the printer will wait for paper to be fed before cancelling the job.

ITEM	SETTINGS	EXPLANATION	
STSTEM ADJUST (cont.)	TIMEOUT INJOB	OFF 5 SEC 10 SEC 20 SEC 30 SEC <b>40 SEC</b> 50 SEC 60 SEC 90 SEC 120 SEC 150 SEC 180 SEC 210 SEC 240 SEC 270 SEC 300 SEC	Specifies how many seconds the printer will wait when received data pauses before forcing a page eject.  In PostScript Emulation mode the job will be cancelled if timeout occurs.
	TIMEOUT LOCAL	0 SEC 5 SEC ~ <b>40 SEC</b> ~ 290 SEC 295 SEC 300 SEC	Sets how long each port is left opened after a job is complete. (The network is excluded.)
	TIMEOUT NET	0 SEC 5 SEC ~ <b>90 SEC</b> ~ 290 SEC 295 SEC 300 SEC	Sets how long the network port is left opened after a job is complete.
	LOW TONER	<b>CONTINUE</b> STOP	Specifies whether the printer should continue printing even after a low toner condition is detected.
	EMPTY COLOR TONER	<b>ALARM</b> CANCEL	Specifies the action when there is an empty color toner.
	JAM RECOVERY	<b>ON</b> OFF	Specifies whether the printer should perform jam recovery after a paper jam has occurred. If <b>ON</b> , the printer will attempt to re-print any pages lost due to a paper jam once the jam has been cleared.
	ERROR REPORT	ON <b>OFF</b>	If <b>ON</b> , the printer will print error details when a PostScript Emulation error occurs. Note: Applies tp PS & PCL XL only.
	HEX DUMP	EXECUTE	Prints out data received from the host PC in hexadecimal Dump.  Turning off the power supply switch restores Normal Mode from HEX Dump Mode.

ITEM			SETTINGS	EXPLANATION
PRINT ADJUST	POSITION ADJUST	MP TRAY	X ADJUST ~ <b>0.00MILLIMETER</b> ~ -2.00MILLIMETER	Adjusts the position of a whole print image in the direction perpendicular to the direction the paper runs, that is horizontally, in 0.25 mm increments. Any parts of the print image that are outside the printable area as a result of this shift will be cropped.
			Y ADJUST ~ <b>0.00MILLIMETER</b> ~ -2.00MILLIMETER	Adjusts the position of a whole print image in the direction the paper runs, that is vertically, in 0.25 mm increments. Any parts of the print image that are outside the printable area as a result of this shift will be cropped.
			DUPLEX X ADJUST ~ <b>0.00MILLIMETER</b> ~ -2.00MILLIMETER	Adjusts the position of a whole print image in the direction perpendicular to the direction the paper runs, that is horizontally, in 0.25 mm increments. Any parts of the print image that are outside the printable area as a result of this shift will be cropped.
			DUPLEX Y ADJUST ~ <b>0.00MILLIMETER</b> ~ -2.00MILLIMETER	Adjusts the position of a whole print image in the direction the paper runs, that is vertically, in 0.25 mm increments. Any parts of the print image that are outside the printable area as a result of this shift will be cropped.
	TRAY1		X ADJUST ~ <b>0.00MILLIMETER</b> ~ -2.00MILLIMETER	Adjusts the position of a whole print image in the direction perpendicular to the direction the paper runs, that is horizontally, in 0.25 mm increments. Any parts of the print image that are outside the printable area as a result of this shift will be cropped.
			Y ADJUST ~ <b>0.00MILLIMETER</b> ~ -2.00MILLIMETER	Adjusts the position of a whole print image in the direction the paper runs, that is vertically, in 0.25 mm increments. Any parts of the print image that are outside the printable area as a result of this shift will be cropped.
			DUPLEX X ADJUST ~ <b>0.00MILLIMETER</b> ~ -2.00MILLIMETER	Adjusts the position of a whole print image in the direction perpendicular to the direction the paper runs, that is horizontally, in 0.25 mm increments. Any parts of the print image that are outside the printable area as a result of this shift will be cropped.
			DUPLEX Y ADJUST ~ <b>0.00MILLIMETER</b> ~ -2.00MILLIMETER	Adjusts the position of a whole print image in the direction the paper runs, that is vertically, in 0.25 mm increments. Any parts of the print image that are outside the printable area as a result of this shift will be cropped.



ITEM				SETTINGS	EXPLANATION
PRINT ADJUST (cont.)	POSITION ADJUST (cont.)	TRAY2	X ADJUST	+2.00MILLIMETER ~ <b>0.00MILLIMETER</b> ~ -2.00MILLIMETER	Adjusts the position of a whole print image in the direction perpendicular to the direction the paper runs, that is horizontally, in 0.25 mm increments.  Any parts of the print image that are outside the printable area as a result of this shift will be cropped.
			Y ADJUST	+2.00MILLIMETER ~ <b>0.00MILLIMETER</b> ~ -2.00MILLIMETER	Adjusts the position of a whole print image in the direction the paper runs, that is vertically, in 0.25 mm increments.  Any parts of the print image that are outside the printable area as a result of this shift will be cropped.
			DUPLEX X ADJUST	+2.00MILLIMETER ~ <b>0.00MILLIMETER</b> ~ -2.00MILLIMETER	Adjusts the position of a whole print image in the direction perpendicular to the direction the paper runs, that is horizontally, in 0.25 mm increments.  Any parts of the print image that are outside the printable area as a result of this shift will be cropped.
			DUPLEX Y ADJUST	+2.00MILLIMETER ~ <b>0.00MILLIMETER</b> ~ -2.00MILLIMETER	Adjusts the position of a whole print image in the direction the paper runs, that is vertically, in 0.25 mm increments.  Any parts of the print image that are outside the printable area as a result of this shift will be cropped.
PAPER BLACK SET			+2 +1 <b>0</b> -1 -2	Used for small adjustments when you experience faded print or light specks / streaking in monochrome printing on white paper.  Select a higher value to reduce fading, or a lower value to reduce specks or streaking in high density print areas.	
PAPER COLOR SET			+2 +1 <b>0</b> -1 -2	As above, but for color printing.	
SMR SETTING			+3 +2 +1 <b>0</b> -1 -2 -3	Sets a correction value for uneven print quality, to correct print variations caused by variations in temperature and humidity or in print density/frequency.	
BG SETTING			+3 +2 +1 <b>0</b> -1 -2 -3	Sets a correction value for dark-colored paper printing, to correct print variations caused by variations in temperature and humidity or in print density/frequency.	

ITEM		SETTINGS	EXPLANATION
PRINT ADJUST (cont.)	DRUM CLEANING	ON <b>OFF</b>	Sets whether to rotate the drum in idle prior to printing in order to reduce any horizontal white lines.  CAUTION: Each additional rotation will shorten the ID life by that amount.
	HIGH HUM. MODE	<b>OFF</b> ON	Set if the paper curl after printing is conspicuous.
	QUIET MODE	ON <b>OFF</b>	Sets Off/On of the quiet printing mode.

## ADMIN SETUP

This menu should only be changed by the System Administrators. In order to gain access to this menu, follow the instructions in ["How to change the settings - administrator"](#) on page 22.

CATEGORY	EXPLANATION
NETWORK SETUP	You can check and change the setting items related to a network and server.
USB SETUP	You can check and change the setting items related to USB.
PRINT SETUP	You can check and change the setting items related to printing.
COLOR MENU	You can check and change the setting items related to the print color.
PS SETUP	You can check and change the setting items related to the PS printer driver.
PCL SETUP	You can check and change the setting items related to the PCL printer driver.
XPS SETUP	You can check and change the setting items related to the XPS printer driver.
IBM PPR SETUP	You can check and change the setting items related to IBM PPR.
EPSON FX SETUP	You can check and change the setting items related to EPSON FX.
PANEL SETUP	You can check and change the setting items related to the panel.
POWER SETUP	You can check and change the setting items related to power.
TRAY SETUP	You can check and change the setting items related to trays.
OTHERS SETUP	You can check and change the other setting items.
SETTINGS	You can check and change the setting items related to setting values.
CHANGE PASSWORD	You can check and change the setting items related to passwords.

## NETWORK SETUP

This menu controls the operation of the printer's network interface.

ITEM	SETTINGS	EXPLANATION
ENABLING DEFAULT GATEWAY	<b>WIRED</b> WIRELESS (INFRASTRUCTURE)	
WIRED	<b>ENABLE</b> DISABLE	
TCP/IP	<b>ENABLE</b> DISABLE	Enables or disables this network protocol.
NETBIOS OVER TCP	<b>ENABLE</b> DISABLE	Sets Enable/Disable of NetBIOS over TCP protocol. Display Conditions: TCP/IP should be enabled.
IP ADDRESS SET	<b>AUTO</b> MANUAL	Specifies whether IP address allocation is automatic (DHCP) or manually assigned.
IPV4 ADDRESS	xxx.xxx.xxx.xxx	Current assigned IP address. To change, press <b>OK</b> and use <b>MENU</b> buttons to increment 1st octet, then press <b>OK</b> again to move on to next octet. When 4th octet has been set, press <b>OK</b> again to register new address.
SUBNET MASK	xxx.xxx.xxx.xxx	Current assigned subnet mask. To change, proceed as above.
GATEWAY ADDRESS	xxx.xxx.xxx.xxx	Current assigned gateway address. To change, proceed as above.
DHCPV6	xxx.xxx.xxx.xxx	Current assigned DHCPV6. To change, proceed as above.
WEB	<b>ENABLE</b> DISABLE	Enables or disables Web config. facility.
TELNET	ENABLE <b>DISABLE</b>	Enables or disables Telnet config. facility.
FTP	ENABLE <b>DISABLE</b>	Enables or disables communication via FTP.
IPSEC	ENABLE <b>DISABLE</b>	Sets Enable/Disable of IPsec. Enable via the web. <b>ENABLE</b> : IPsec is available. <b>DISABLE</b> : IPsec is not available.
SNMP	<b>ENABLE</b> DISABLE	Enables or disables SNMP protocol.
NETWORK SCALE	<b>NORMAL</b> SMALL	Selects network size. When <b>NORMAL</b> is selected, printer can work effectively, even when connected to a HUB that has a spanning tree feature. However, printer start up time gets longer when computers are connected with two or three small LANs. When <b>SMALL</b> is selected, computers can cover from two or three small LANs to a large LAN, but may not work effectively when connected to a HUB that has a spanning tree feature.
GIGABIT NETWORK	ENABLE <b>DISABLE</b>	Sets whether to enable access with Gigabit Ethernet.

ITEM	SETTINGS	EXPLANATION
HUB LINK SETTING	<b>AUTO NEGOTIATE</b> 100BASE-TX FULL 100BASE-TX HALF 10BASE-T FULL 10BASE-T HALF	Sets full or half duplex for communication via a network hub. When <b>AUTO NEGOTIATE</b> is set, negotiation is done automatically.
FACTORY DEFAULTS	EXECUTE	Reloads the settings present when the unit was setup by the manufacturer.

## USB SETUP

This menu controls the operation of the printer's USB data interface.

ITEM	SETTINGS	EXPLANATION
USB	<b>ENABLE</b> DISABLE	Sets USB I/F Enable/Disable.
SPEED	<b>480 Mbps</b> 12 Mbps	Selects the USB interface speed.
SOFT RESET	ENABLE <b>DISABLE</b>	Enables or disables the SOFT RESET command.
SERIAL NUMBER	<b>ENABLE</b> DISABLE	Specifies whether to <b>ENABLE</b> or <b>DISABLE</b> a USB serial number. The USB serial number is used to identify the USB device connected to your PC.
OFFLINE RECEIVE	ENABLE <b>DISABLE</b>	Enables or disables this function. When set to Enable, the interface retains a receive possible state even when switching to Offline. Interface sends the BUSY signal only when the receive buffer is full or a service call occurs.
CONNECTED HOST	<b>NORMAL</b> SPECIFIC	

## PRINT SETUP

This menu provides adjustment of various print job related functions.

ITEM	SETTINGS	EXPLANATION
PERSONALITY	<b>AUTO EMULATION</b> PCL XPS IBM PPR III XL EPSON FX PS3 EMULATION	Selects a printer language.
COPIES	<b>1</b> ~ 999	Enter the number of copies of a document to be printed from 1 to 999.
DUPLEX	ON <b>OFF</b>	Switches the Duplex (2 sided) function ON/OFF.

ITEM		SETTINGS	EXPLANATION
BINDING		<b>LONG EDGE</b> SHORT EDGE	Sets the default binding to SEF or LEF.
MEDIA CHECK		<b>ENABLE</b> DISABLE	Determines whether the printer check the size of paper loaded matches that required for the document sent to print.
OVERRIDE A4/LT		NO <b>YES</b>	If enabled, when the paper size of a job is set to A4 but there is no A4 set in the printer, if there is Letter paper in the printer, the job will be printed on Letter paper without requesting the user to fill the paper tray with A4 paper. Similarly, when the paper size of a job is set to Letter but there is no Letter set in the printer, if there is A4 paper in the printer, the job will be printed on A4 paper without requesting the user to fill the paper tray with Letter paper.
RESOLUTION		600 DPI <b>600 x 1200 DPI</b> 600 DPI M-LEVEL	Sets the default resolution for printing (dots per inch).
TONER SAVE	TONER SAVE LEVEL	<b>OFF</b> LOW MIDDLE HIGH	Set the toner save level.
	TONER SAVE COLOR	<b>ALL</b> EXCEPT100% BLACK	Specify toner save for 100% black. All: Enables toner save for all colors. Except 100% Black: Disables toner save for 100% black.
MONO-PRINT SPEED		<b>AUTO</b> COLOR SPEED NORMAL SPEED	Sets the monochrome print speed. Prints at the most appropriate speed for page process if <b>AUTO</b> is set. Prints always at the color print speed if <b>COLOR SPEED</b> is set. Prints always at the monochrome print speed if <b>NORMAL SPEED</b> is set.
ORIENTATION		<b>PORTRAIT</b> LANDSCAPE	Selects default page orientation between portrait (tall) and landscape (wide). - (PCL, IBMPPR & EPSON FX only)

ITEM	SETTINGS	EXPLANATION
EDIT SIZE	<b>CASSETTE SIZE</b> A4 A5 A6 B5 B6 B6 Half LEGAL14 LEGAL13.5 LEGAL13 LETTER EXECUTIVE STATEMENT 8.5"SQ Folio 16K(184x260mm) 16K(195x270mm) 16K(197x273mm) CUSTOM INDEXCARD 4x6 INCH 5x7 INCH COM-9 ENVELOPE COM-10 ENVELOPE MONARCH ENV DL ENVELOPE C5 ENVELOPE HAGAKI OUFUKUHAGAKI NAGAGATA #3 NAGAGATA #4 YOUGATA #4	Sets the size of the printable page area to match the size of paper in use. This is not the same as the physical paper size, which is always slightly larger. For dimensions of physical page sizes, see "Paper Recommendations" section in this guide. (PCL/IBMPPR/EPSONFX only)
X DIMENSION	64 MILLIMETER (2.5 INCH) ~ 210 MILLIMETER (8.3 INCH) ~ 216 MILLIMETER (8.5 INCH)	Specifies paper width of Custom paper as a default value. Sets a paper size at right angles to the paper run direction. Note: The default setting varies depending on the sales area.

ITEM	SETTINGS	EXPLANATION
Y DIMENSION	127 MILLIMETER (5.0 INCH) ~ 279 MILLIMETER (11.0 INCH) ~ 297 MILLIMETER (11.7 INCH) ~ 356 MILLIMETER (14.0 INCH) ~ 1321 MILLIMETER (52.0 INCH)	Specifies paper length of Custom paper as a default value. Sets a paper size in the same direction as the paper run direction. Note: The default setting varies depending on the sales area.
TRAPPING	<b>OFF</b> NARROW WIDE	Specifies the trapping value. Set it when there is an empty gap between two colors.

## COLOR MENU

The printer automatically adjusts color balance and density at appropriate intervals, optimising the printed output for bright white paper viewed in natural daylight conditions.

The items on this menu provide a means of changing the default settings for special or particularly difficult print jobs.

ITEM	SETTINGS	EXPLANATION	
DENSITY CONTROL	<b>AUTO</b> MANUAL		
ADJUST DENSITY	EXECUTE		
COLOR TUNING	PRINT PATTERN		
CYAN TUNING	CYAN HIGHLIGHT	-3~ <b>0</b> ~+3	Adjusts image density for each color component (cyan,magenta, yellow and black). Normal setting is 0.
	CYAN MID-TONE	-3~ <b>0</b> ~+3	
	CYAN DARK	-3~ <b>0</b> ~+3	
MAGENTA TUNING	MAGENTA HIGHLIGHT	-3~ <b>0</b> ~+3	
	MAGENTA MID-TONE	-3~ <b>0</b> ~+3	
	MAGENTA DARK	-3~ <b>0</b> ~+3	
YELLOW TUNING	YELLOW HIGHLIGHT	-3~ <b>0</b> ~+3	
	YELLOW MID-TONE	-3~ <b>0</b> ~+3	
	MYELLOW DARK	-3~ <b>0</b> ~+3	
BLACK TUNING	BLACK HIGHLIGHT	-3~ <b>0</b> ~+3	
	BLACK MID-TONE	-3~ <b>0</b> ~+3	
	BLACK DARK	-3~ <b>0</b> ~+3	



ITEM		SETTINGS	EXPLANATION
COLOR DENSITY	CYAN DENSITY	-3~ <b>0</b> ~+3	Adjusts the density of each color (cyan,magenta, yellow and black). Normal setting is 0.
	MAGENTA DENSITY	-3~ <b>0</b> ~+3	
	YELLOW DENSITY	-3~ <b>0</b> ~+3	
	BLACK DENSITY	-3~ <b>0</b> ~+3	
ADJUST REGISTRATION		EXECUTE	Performs automatic color registration adjustment. Normally this is done on power on and when output tray is opened and then closed. This process accurately aligns the cyan, magenta and yellow images to the black image.
INK SIMULATION		<b>OFF</b> SWOP ISO COATED JAPAN	Selects from a range of industry standard color swatches. Note: This function only applies to PS models
UCR		<b>LOW</b> MEDIUM HIGH	Selects limitation of the toner layer thickness. If paper curl occurs in dark printing, selecting <b>MEDIUM</b> or <b>HIGH</b> sometimes helps reduce curl.
CMY100% DENSITY		ENABLE <b>DISABLE</b>	When enabled, black areas are produced using 100% C, M, and Y instead of black. This results in a glossier finish.
CMYK CONVERSION		<b>ON</b> OFF	Setting to <b>OFF</b> will simplify the conversion process of CMYK data, which will reduce the processing time. This setting is ignored when Ink Simulation function is used. Note: This function only applies to PS models

## PS SETUP

ITEM	SETTINGS	EXPLANATION
L1 TRAY	<b>TYPE1</b> TYPE2	<b>TYPE1</b> : The tray selection number for the level 1 operator begins with 1. <b>TYPE2</b> : The number begins with 0.
NET PS-PROTOCOL	ASCII <b>RAW</b>	Specifies a communication protocol mode for PS data from a network.
USB PS-PROTOCOL	ASCII <b>RAW</b>	Specifies a communication protocol mode for PS data from USB.
PDF PAPER SIZE	<b>CURRENT TRAY SIZE</b> SIZE IN PDF FILE SCALING SIZE	Select the paper size of PDF Direct Print.
PDF SCALING SIZE	1% ~ <b>99%</b>	Specifies scaling size by percent when PDF Paper Size is set to Scaling Size.

## PCL SETUP

ITEM	SETTINGS	EXPLANATION
FONT SOURCE	<b>RESIDENT</b>	Specifies the location of the PCL default font. Normally this will be INTERNAL unless additional fonts are installed in the expansion ROM slot or additional fonts have been downloaded to RAM as permanent fonts.
FONT NO.	<b>10</b> ~ I90	Sets the current default font number from the currently selected source.
FONT PITCH	0.44 CPI ~ <b>10.00 CPI</b> ~ 99.99 CPI	Sets the width of the PCL default font in characters/inch (CPI). Default font is the fixed-pitch, scalable font. The value is displayed to the second decimal place. Displayed only when the font selected in Font No. is fixed-spacing, scalable font.
FONT HEIGHT	4.00 POINT ~ <b>12.00 POINT</b> ~ 999.75 POINT	Height of the PCL default font. Note: This menu item is displayed only when the font selected in Font No. is a proportional-spacing, scalable font.
SYMBOL SET	<b>PC-8</b> (Default Symbol Set only shown)	Selects a PCL symbol set.
A4 PRINT WIDTH	<b>78 COLUMN</b> 80 COLUMN	Sets the number of columns subject to Auto LF with A4 paper in PCL. This is the value when Auto CR/LF Mode is set to OFF with the 10CPI character.
WHITE PAGE SKIP	ON <b>OFF</b>	Selects whether blank pages are printed or not.
CR FUNCTION	<b>CR</b> CR+LF	Selects whether a received carriage return character (0Dh) also causes a line feed.
LF FUNCTION	<b>LF</b> LF+CR	Selects whether a received line feed character (0Ah) also causes a carriage return.
PRINT MARGIN	<b>NORMAL</b> 1/5 INCH 1/6 INCH	Sets the non-printable page area. <b>NORMAL</b> is PCL compatible.
TRUE BLACK	ON <b>OFF</b>	PCL: Sets if to use Composite Black (CMYK mixed) or Pure Black (K only) for the black (100%) in image data.
PEN WIDTH ADJUST	<b>ON</b> OFF	When minimum width is specified in PCL, sometimes a 1-dot line, looks broken. With <b>PEN WIDTH ADJUST</b> set to <b>ON</b> , when the minimum width is specified, the line width will be emphasized so as to look wider than a 1-dot line. With <b>PEN WIDTH ADJUST</b> set to <b>OFF</b> , the line will appear as before.

ITEM		SETTINGS	EXPLANATION
TRAY ID#	MP TRAY	1 ~ <b>4</b> ~ 59	Sets the # to specify the MP tray for the paper feed destination command (ESC&l#H) in PCL5e emulation.
	TRAY1	<b>1</b> ~ 59	Sets the # to specify Tray 1 for the paper feed destination command (ESC&l#H) in PCL5e emulation.
	TRAY2	1 ~ <b>5</b> ~ 59	Sets the # to specify Tray 2 for the paper feed destination command (ESC&l#H) in PCL5e emulation. (Displayed only if Tray 2 is installed).

### XPS SETUP

ITEM	SETTINGS	EXPLANATION
DIGITAL SIGNATURE	PRINT EVEN NG PRINT ONLY OK <b>OFF</b>	Sets the DigitalSignature function.
DISCARD CONTROL	<b>AUTO</b> EACH PAGE OFF	Sets the DiscardControl function.
MC MODE	<b>ON</b> OFF	Sets the MarkupComaptibility function.
UNZIP MODE	AUTO <b>SPEED</b> PRINT	Specifies the unzip method for XPS flies.
WHITE PAGE SKIP	ON <b>OFF</b>	Sets whether or not to eject pages that contain no print data (blank pages) using XPS.

## IBM PPR SETUP

ITEM	SETTINGS	EXPLANATION
CHARACTER PITCH	<b>10 CPI</b> 12 CPI 17 CPI 20 CPI PROPORTIONAL	Specifies character pitch in IBM PPR emulation.
FONT CONDENSE	<b>12CPI TO 20CPI</b> 12CPI TO 12CPI	Specifies 12CPI pitch for Condense Mode.
CHARACTER SET	<b>SET-2</b> SET-1	Specifies a character set.
SYMBOL SET	<b>IBM-437</b> (Default Symbol Set only shown)	Specifies a symbol set.
LETTER O STYLE	ENABLE <b>DISABLE</b>	Specifies the style that replaces 9BH with letter o and 9DH with a zero.
ZERO CHARACTER	<b>NORMAL</b> SLASHED	Sets the zero to be slashed or unslashed.
LINE PITCH	<b>6 LPI</b> 8 LPI	Specifies the line spacing.
WHITE PAGE SKIP	ON <b>OFF</b>	Selects whether blank pages are printed or not.
CR FUNCTION	<b>CR</b> CR+LF	Selects whether a received carriage return character (0Dh) also causes a line feed.
LF FUNCTION	<b>LF</b> LF+CR	Sets performance when LF code is received.
LINE LENGTH	<b>80 COLUMN</b> 136 COLUMN	Specifies the number of characters per line.
FORM LENGTH	11 INCH 11.7 INCH 12 INCH	Specifies the length of paper. Note: The default setting varies depending on the sales area.
TOF POSITION	<b>0.0 INCH</b> 0.1 INCH ~ 1.0 INCH	Specifies the distance of print from the top edge of the paper.
LEFT MARGIN	<b>0.0 INCH</b> 0.1 INCH ~ 1.0 INCH	Specifies the distance of print from the left hand edge of the paper.
FIT TO LETTER	ENABLE DISABLE	Sets the printing mode that can fit print data, equivalent to 11 inches (66 lines), in the LETTER-size printable area. Note: The default setting varies depending on the sales area.
TEXT HEIGHT	<b>SAME</b> DIFF	Sets the height of a character. <b>SAME:</b> Regardless of CPI, same height. <b>DIFF:</b> As CPI, character heights vary.

## EPSON FX SETUP

ITEM	SETTINGS	EXPLANATION
CHARACTER PITCH	<b>10 CPI</b> 12 CPI 17 CPI 20 CPI PROPORTIONAL	Specifies character pitch in this emulation.
CHARACTER SET	<b>SET-2</b> SET-1	Specifies a character set.
SYMBOL SET	<b>IBM-437</b> (Default Symbol Set only shown)	Specifies a symbol set.
LETTER O STYLE	ENABLE <b>DISABLE</b>	Specifies the style that replaces 9BH with letter o and 9DH with a zero.
ZERO CHARACTER	<b>NORMAL</b> SLASHED	Sets the zero to be slashed or unslashed.
LINE PITCH	<b>6 LPI</b> 8 LPI	Specifies the line spacing.
WHITE PAGE SKIP	ON <b>OFF</b>	Selects whether blank pages are printed or not.
CR FUNCTION	<b>CR</b> CR+LF	Selects whether a received carriage return character (0Dh) also causes a line feed.
LINE LENGTH	<b>80 COLUMN</b> 136 COLUMN	Specifies the number of characters per line.
FORM LENGTH	11 INCH 11.7 INCH 12 INCH	Specifies the length of paper. Note: The default setting varies depending on the sales area.
TOF POSITION	<b>0.0 INCH</b> 0.1 INCH ~ 1.0 INCH	Specifies the distance of print from the top edge of the paper.
LEFT MARGIN	<b>0.0 INCH</b> 0.1 INCH ~ 1.0 INCH	Specifies the distance of print from the left hand edge of the paper.
FIT TO LETTER	ENABLE DISABLE	Sets the printing mode that can fit print data, equivalent to 11 inches (66 lines), in the LETTER-size printable area.
TEXT HEIGHT	<b>SAME</b> DIFF	Sets the height of a character. <b>SAME:</b> Regardless of CPI, same height. <b>DIFF:</b> As CPI, character heights vary.

## PANEL SETUP

ITEM	SETTINGS	EXPLANATION
NEARLIFE STATUS	<b>ENABLE</b> DISABLE	Set LCD panel control at the time of near-life warning for drum. <b>ENABLE:</b> Display a near-life warning. <b>DISABLE:</b> Do not display a near-life warning.
NEARLIFE LED	<b>ENABLE</b> DISABLE	Enables/disables illumination of front panel LED when "near-end-of-life" warning of a toner or drum occurs. Attention LED is lit when setting is enabled, inhibited when disabled.

## POWER SETUP

ITEM	SETTINGS	EXPLANATION
AUTO PW OFF	ENABLE <b>AUTO CONFIG</b> DISABLE	Sets the Auto Power Off operation. <b>ENABLE:</b> When the printer is not used for a period of time, it turns off the power automatically. <b>AUTO CONFIG:</b> Auto power off is enabled, however, the printer will not turn off the power under the following conditions: > An Ethernet cable is plugged to the network interface connection. > The wireless LAN is enabled. Note: The default setting varies depending on the sales area.
POWER RETURN	<b>MANUAL</b> STATE CONTINUE	Set the power on method after energize.

## TRAY SETUP

ITEM	SETTINGS	EXPLANATION
UNIT OF MEASURE	INCH MILLIMETER	Selects the unit of measure. Note: The default setting varies depending on the sales area.
DEFAULT PAPERSIZE	A4 LETTER	Set default paper size. Note: The default setting varies depending on the sales area.

## OTHERS SETUP

ITEM		SETTINGS	EXPLANATION
RAM SETUP	RECEIVE BUF SIZE	<b>AUTO</b> 0.5 MB 1 MB 2 MB 4 MB 8 MB 16 MB 32 MB	Sets the size of the receive buffer.
	RESOURCE SAVE	<b>AUTO</b> <b>OFF</b> 0.5 MB 1 MB 2 MB 4 MB 8 MB 16 MB 32 MB	Sets the size of the resource saving area.
FLASH SETUP	FLASH INITIALIZE	EXECUTE	Initialises the resident FLASH MEMORY. If <b>NO</b> is selected, the machine will go back to the source menu. If <b>YES</b> is selected, the machine will be automatically rebooted and initialize the FLASH memory.
	FORMATTING	<b>PCL</b> COMMON PS	Format the specified partition. Press the OK button and the following message displays. <b>ARE YOU SURE?</b> <b>YES/NO</b> If <b>NO</b> is selected, the display will go back to the source menu. If <b>YES</b> is selected, the printer will automatically reboot and initialise the specified partition.
STORAGE SETUP	ENABLE INITIAL	<b>NO</b> YES	Prevents a setting change accompanying initialization of BlockDeveice(FLASH).
JOB LOG SETUP	CLEAR JOB LOG	EXECUTE	Clears the saved job logs.
SECURITY SETUP	ACCESS CONTROL	ENABLE <b>DISABLE</b>	Displays the security setting menu.
LANGUAGE SETUP	LANGUAGE SELECT	~ ENGLISH ~	Selects display language for the LCD panel.
	LANGUAGE INITIALIZE	EXECUTE	Initialize the message file loaded in FLASH.

ITEM		SETTINGS	EXPLANATION
JOB CANCEL SETUP	CANCEL KEY BEHAVIOR	<b>SHORT</b> LONG OFF	Specify the behavior when Cancel button is pressed in printing.
	INQUIRY DISPLAY	<b>ON</b> OFF	Specify whether the Job Cancel selection request will be displayed. <b>ON</b> : Display when Job Cancelling. <b>OFF</b> : Do not display.
	FOCUS POSITION	<b>YES</b> NO	Specify the default selection of Job Cancel request.
	DISPLAY TIMEOUT	60 ~ <b>180</b> ~ 300	Specify the timeout of Job Cancel selection request. When the time passed, the printing will be continued as Job Cancel = No.
NEARLIFE SETUP	DRUM NEARLIFE	500 ~ <b>1000</b> ~ 3000	
	FUSER NEARLIFE	500 ~ <b>1000</b> ~ 3000	
	BELT NEARLIFE	500 ~ <b>1000</b> ~ 3000	
ERASE PRIVACY DATA		EXECUTE	Erase the registered privacy data and the stored data in the printer.
BUS. PHONE SETUP	BUS. PHONE COOPE	ENABLE <b>DISABLE</b>	
	CONNECT ADDRESS	0.0.0.0 ~ 255.255.255.255	
	CONNECT PORT NO.	1 ~ <b>59000</b> ~ 65535	

## SETTINGS

ITEM	SETTINGS	EXPLANATION
MENU RESET	EXECUTE	Resets menus to default settings.

## CHANGE PASSWORD

ITEM	SETTINGS	EXPLANATION
NEW PASSWORD	*****	Set a new password for entering the administrator's menu. Password should be from 6 to 12 digits of alpha/numeric characters (or mix). The default value is "999999". The printer will restart after the <b>ADMIN MENU</b> .
VERIFY PASSWORD	*****	Verification of above.



## PRINT STATISTICS

This menu should only be changed by the System Administrators. In order to gain access to this menu, follow the instructions in ["How to change the settings - administrator" on page 22](#), but hold down the **MENU** button instead of the **OK** button. In this case, the default password is **0000**.

This menu is in **ENGLISH** only.

ITEM		SETTINGS	EXPLANATION
ENTER PASSWORD		nnnn	Enters a password to enter <b>PRINT STATISTICS</b> menu. The default password is "0000." <b>PRINT STATISTICS</b> category is not shown when Print Statistics function is not supported.
USAGE REPORT		<b>ENABLE/</b> <b>DISABLE</b>	Enables/Disables the printing of the Usage Report. When changing a setting value, the printer is rebooted.
MAINTENANCE CNT		<b>ENABLE/</b> <b>DISABLE</b>	Indication of frequency of consumable exchange/non indication is set. When Enable is set, also the maintenance counter is indicated in together. Conditions for display: Enable must be selected in <b>PRINT STATISTICS &gt; USAGE REPORT</b> .
RST MAIN CNT		EXECUTE	Resets the main counter.
RST SUPPLIES CNT		EXECUTE	Resets the number of replacement of consumables.
CHANGE PASSWORD	NEW PASSWORD	****	Sets a new password to enter <b>PRINT STATISTICS</b> menu.
	VERIFY PASSWORD	****	Verifies the change

## AIRPRINT

ITEM		SETTINGS	EXPLANATION
AirPrint		<b>ENABLE</b> <b>DISABLE</b>	Enable AirPrint function. <b>ENABLE</b> is displayed only when AirPrint is changed to Disabled by network error etc., select Enable in this menu, network will be re-initialized, and return to stand-by UI. When AirPrint is enabled, <b>DISABLE</b> will not be displayed. Select <b>ENABLE</b> in this menu, just return to stand-by UI. Network Re-initializing will not be executed. There is not a menu for changing AirPrint to disable.

## GOOGLE CLOUD PRINT

ITEM		SETTINGS	EXPLANATION
PRINT MANUALLY			Prints manually.
DELETE REGISTERED INFO			Deletes the registered information.
REGISTER TO Google Cloud Print			Registers to Google Cloud Print.
SETTINGS OF Google Cloud Print	USING CLOUD SERVICE	<b>ENABLE</b> PAUSE DISABLE	Sets whether or not to use cloud service.
	DNS PRIMARY	xxx.xxx.xxx.xxx	Sets the DNS server(Primary).
	DNS SECONDARY	xxx.xxx.xxx.xxx	Sets the DNS server(Secondary).
	PROXY	ENABLE <b>DISABLE</b>	Sets whether or not to use a proxy server.
	PROXY SERVER		Sets the proxy server.
	PROXY PORT NO.	1 ~ <b>8080</b> ~ 65535	Sets the port number of the proxy server.
	PROXY USER ID		Sets the proxy user ID.
PROXY PASSWORD		Sets the proxy password.	

## WIRELESS SETTING

If the optional Wireless LAN Module is fitted.

ITEM		SETTINGS	EXPLANATION	
WIRELESS (INFRA-STRUCTURE) SETTING	WIRELESS(INFRASTRUCTURE)		ENABLE <b>DISABLE</b>	Enables/disables the wireless LAN (Infrastructure).
	NETWORK SETTING	IP ADDRESS SET	<b>AUTO</b> MANUAL	Select the IP address setting method.
		IPV4 ADDRESS	xxx.xxx.xxx.xxx	Sets the IP Address.
		SUBNET MASK	xxx.xxx.xxx.xxx	Sets the Subnet Mask.
		GATEWAY ADDRESS	xxx.xxx.xxx.xxx	Sets the Gateway (default router) address.
		DHCPV6	ENABLE <b>DISABLE</b>	Sets enable/disable of DHCPv6.
	WPS SETUP		WPS-PBC	Executes WPS-PBC.
			WPS-PIN	Executes WPS-PIN.
	WIRELESS SELECTION	xxxxxx		Lists the detected wireless LAN (AP mode).
	MANUAL SETUP	SSID		Input the SSID.
		SECURITY	<b>DISABLE</b> WEP WPA/WPA2-PSK WPA2-PSK	Sets the security function of the wireless LAN.
		WEP KEY		Input WEP Key. 5-26 digits can be inputed.
		WPA ENCRYPTION TYPE	<b>AES</b> TKIP/AES	WPA2-PSK coding method.
		WPA PRE-SHARED KEY		Input the Pre Shared Key.
	RECONNECTION	EXECUTE		Wireless reconnection is executed.

## WIRELESS (AP MODE) SETTING

If the optional Wireless LAN Module is fitted.

ITEM		SETTINGS	EXPLANATION	
WIRELESS (AP MODE) SETTING	WIRELESS (AP MODE)	ENABLE <b>DISABLE</b>	Enables/disables the wireless LAN (AP mode).	
	AUTOMATIC SETUP (PUSHBUTTON)		When the OK button is pressed and the Yes/No confirmation screen is displayed, if Yes is selected, automatic connection can be started with a push-button.	
	MANUAL SETUP	SSID		Displays the SSID.
		PASSWORD		Displays the password.
	CONNECTION SETTING	SSID		Input the SSID.
		PASSWORD		Input the password.
		IPV4 ADDRESS	xxx.xxx.xxx.xxx	Input the IP address.
AP MODE USER SETTING	ENABLE <b>DISABLE</b>	Sets whether or not to disclose the AP mode information to users other than the administrator. <b>ENABLE:</b> Disclose user. <b>DISABLE:</b> Don't disclose user.		

## BOOT MENU

To enter the boot menu, you should holding on the **OK** button as the same time as the power is turned on.

ITEM		SETTINGS	EXPLANATION
ENTER PASSWORD		*****	The password to enter <b>BOOT MENU</b> is input. The password is same as the password to enter <b>ADMIN SETUP</b> .
WIRELESS MODULE		ENABLE <b>DISABLE</b>	A wireless LAN module is set as enable/disable. Even when removing a wireless LAN module after making it enable, this menu continues enable.
SIDM MENU	SIDM MANUAL ID#	0 ~ <b>2</b> ~ 9	Sets the Pn specified by MANUAL in the CSF control command (ESC EM Pn) of MANUAL-1 ID No. FX/PPR emulation.
	SIDM MANUAL2 ID#	0 ~ <b>3</b> ~ 9	Sets the Pn specified by MANUAL in the CSF control command (ESC EM Pn) of MANUAL-2 ID No. FX/PPR emulation.
	SIDM MP TRAY ID#	0 ~ <b>4</b> ~ 9	Sets the Pn specified by TRAY0 (MP Tray) in the CSF control command (ESC EM Pn) of MP Tray ID No. FX/PPR emulation.

ITEM		SETTINGS	EXPLANATION
SIDM MENU (cont.)	SIDM TRAY1 ID#	0 <b>1</b> ~ 9	Sets the Pn specified by TRAY1 in the CSF control command (ESC EM Pn) of Tray 1 ID No. FX/PPR emulation.
	SIDM TRAY2 ID#	0 ~ <b>5</b> ~ 9	Sets the Pn specified by TRAY2 in the CSF control command (ESC EM Pn) of Tray 2 ID No. FX/PPR emulation. (If tray 2 is installed.)
MENU LOCKOUT		ENABLE <b>DISABLE</b>	Sets enable/disable of Menu Lockout function. <b>ENABLE:</b> It isn't possible to enter the menu mode. <b>DISABLE:</b> It's possible to enter the menu mode.
PANEL LOCKOUT		MODE1 MODE2 OFF	Sets on/off Lockout function for buttons on the operator panel. <b>MODE1:</b> All buttons except for Online, OK, Cancel and Power save button are locked out. <b>MODE2:</b> All buttons except for Online and OK button are locked out. <b>OFF:</b> All buttons aren't locked out.
MENU OPERATION SETUP	UP/DOWN KEY	<b>NORMAL TYPE</b> OLD TYPE	When choosing Category/Item/Value by the menu mode, movement of Menu UP/DOWN button is defined. <b>NORMAL TYPE:</b> When a Menu DOWN button is pressed, the choices move to the next item (the way under the indication list). When a Menu UP button is pressed, the choices move to the previous item (the way on the indication list). <b>OLD TYPE:</b> When a Menu UP button is pressed, the choices move to the next item (the way under the indication list). When a Menu DOWN button is pressed, the choices move to the previous item (the way on the indication list).

# MAINTENANCE

## REPLACING CONSUMABLE ITEMS

**Only use genuine original consumables to ensure the best quality and performance from your hardware. Non original products may adversely affect your printer's performance and invalidate your warranty.**

### TONER CARTRIDGE REPLACEMENT

---

*NOTE*

*When the LCD display indicates TONER LOW, or if print appears faded, first open output tray and try tapping the cartridge a few times to evenly distribute the toner powder. This will enable you to obtain the best "yield" from your toner cartridge.*

---

#### **CAUTION!**

**To avoid toner wastage and possible toner sensor errors, do not change the toner cartridge(s) until "TONER EMPTY" is displayed.**

The toner used in this printer is a very fine dry powder. It is contained in four cartridges: one each for cyan, magenta, yellow and black.

Have a sheet of paper handy so that you have somewhere to place the used cartridge while you install the new one.

Dispose of the old cartridge responsibly, inside the pack that the new one came in. Follow any regulations, recommendations, etc., which may be in force concerning waste recycling.

If you do spill any toner powder, lightly brush it off. If this is not enough, use a cool, damp cloth to remove any residue.

Do not use hot water, and never use solvents of any kind. They will make stains permanent.

#### **WARNING!**

**If you inhale any toner or get it in your eyes, drink a little water or bathe your eyes liberally in cold water. Seek medical attention immediately.**

1. Press the cover release and open the printer's output tray fully.

#### **WARNING!**

**If the printer has been powered on, the fuser will be hot. This area is clearly labelled. Do not touch.**

- 2.** Note the positions of the four cartridges. It is essential that they go back in the same order.

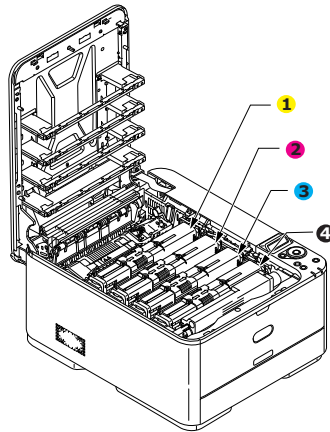

1. Yellow cartridge      2. Magenta cartridge  
3. Cyan cartridge      4. Black cartridge

- (a) Slide the colored release collar on the cartridge to be replaced fully towards the right hand side of the printer.

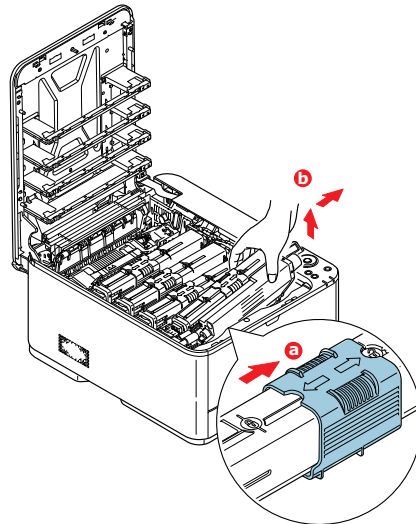

- (b) Lift the right-hand end of the cartridge and then draw the cartridge to the right to release the left-hand end as shown, and withdraw the toner cartridge out of the printer.

- 3.** Put the cartridge down gently onto a piece of paper to prevent toner from marking your furniture.
- 4.** Clean the top of the ID unit with a clean, lint free cloth.

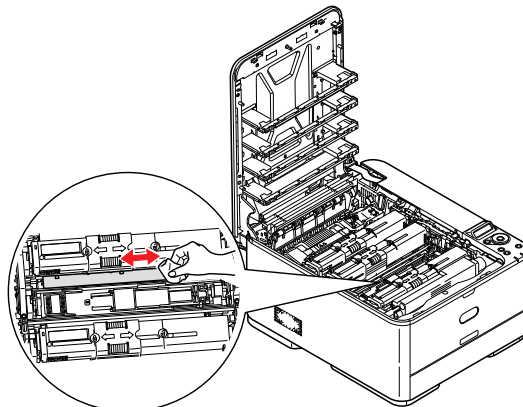

5. Remove the new cartridge from its box but leave its wrapping material in place for the moment.
6. Gently shake the new cartridge from end to end several times to loosen and distribute the toner evenly inside the cartridge.

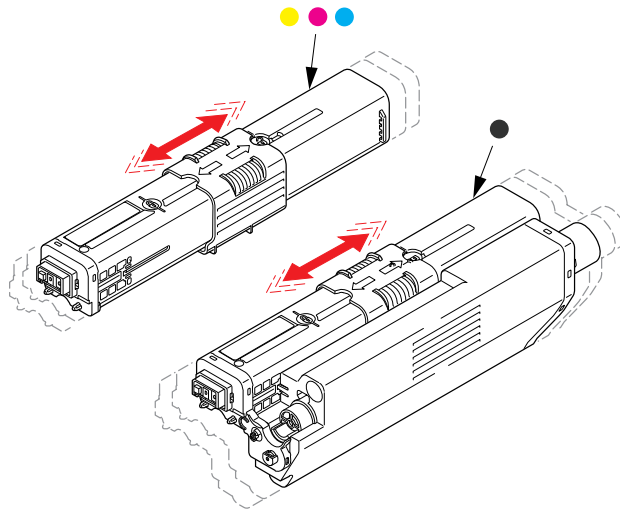

7. Remove the wrapping material.
8. Holding the cartridge by its top centre, lower it into the printer over the image drum unit from which the old cartridge was removed.
9. Insert the left end of the cartridge into the top of the image drum unit first, pushing it against the spring on the drum unit, then lower the right end of the cartridge down onto the image drum unit.
10. Pressing gently down on the cartridge to ensure that it is firmly seated, slide the colored collar fully towards the left hand side of the printer. This will lock the cartridge into place and release toner into the image drum unit.

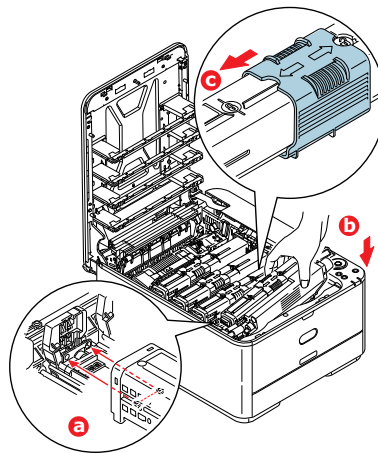



- 11.** Gently wipe the LED head surface with a clean, lint free cloth.

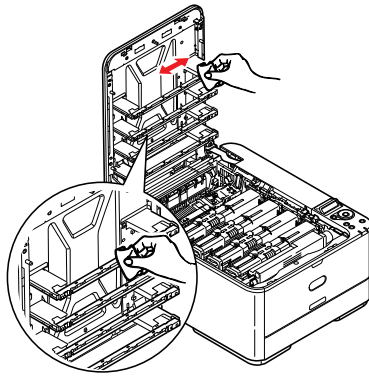

- 12.** Finally, close output tray and press down firmly at both sides so that the cover latches closed.

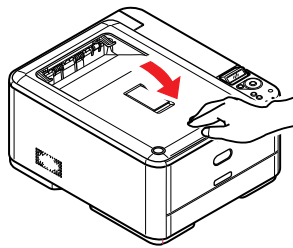

## REPLACING THE TRANSFER BELT UNIT

The belt unit is located under the image drum assembly.

Switch off the printer and allow the fuser to cool for about 10 minutes before opening output tray.

1. Press the cover release and open the printer's output tray fully.

### WARNING!

**If the printer has been powered on, the fuser will be hot. This area is clearly labelled. Do not touch.**

2. Holding it by its handles, lift the image drum assembly, complete with toner cartridges, up and out of the printer.

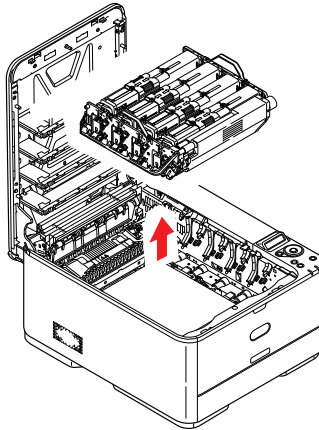

3. Place the assembly in a safe place away from direct sources of heat and light.

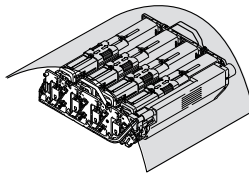

### CAUTION!

**The green image drum surface at the base of each cartridge is very delicate and light sensitive. Do not touch it and do not expose it to normal room light for more than 5 minutes. If the drum unit needs to be out of the printer for longer than this, please wrap the cartridge inside a black plastic bag to keep it away from light. Never expose the drum to direct sunlight or very bright room lighting.**

4. Pull the locking levers at each side of the transfer belt up and towards the front of the machine.

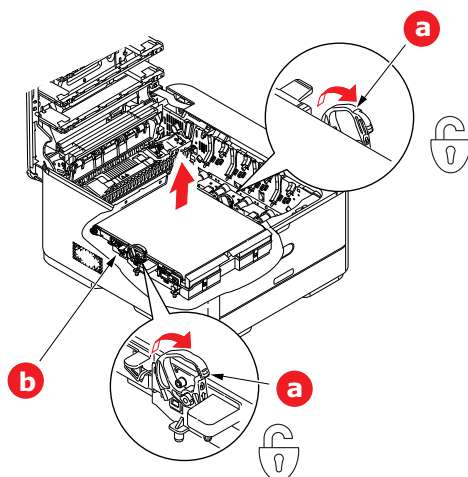

5. Using the locking levers (a), lift the belt (b) upwards and withdraw from the machine.
6. Lower the new belt unit into place, with the drive gear towards the rear of the printer. Locate the drive gear into the gear inside the printer by the rear right corner of the unit, and lower the belt unit flat inside the printer.

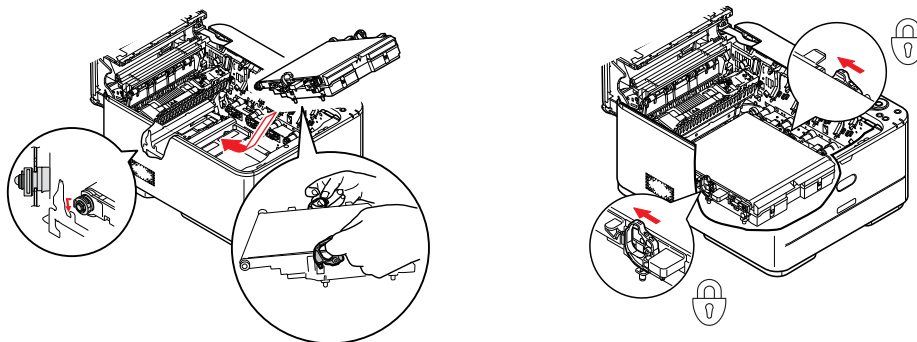

7. Push the locking levers towards the rear of the machine. This will secure the belt unit in place.
8. Holding the image drum assembly by its handles, lower it into place in the machine, locating the pegs at the sides into their slots in the sides of the printer cavity.

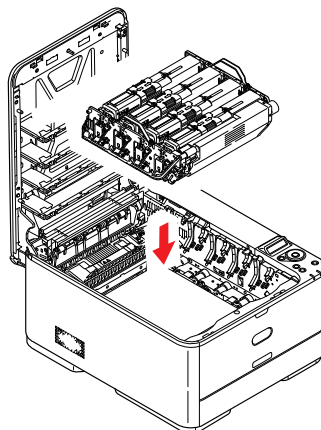

9. Finally, close output tray and press down firmly at both sides so that the cover latches closed.

## FUSER REPLACEMENT

The fuser is located inside the printer just behind the toner cartridges.

### WARNING!

**If the printer has recently been powered on, some fuser components will be very hot. Handle the fuser with extreme care, holding it only by its handle, which will only be mildly warm to the touch. A warning label clearly indicates the area. If in doubt, switch the printer off and wait at least 10 minutes for the fuser to cool before opening the printer cover.**

1. Press the cover release and open the printer's output tray fully.
2. Identify the fuser handle (a) on the top of the fuser unit.

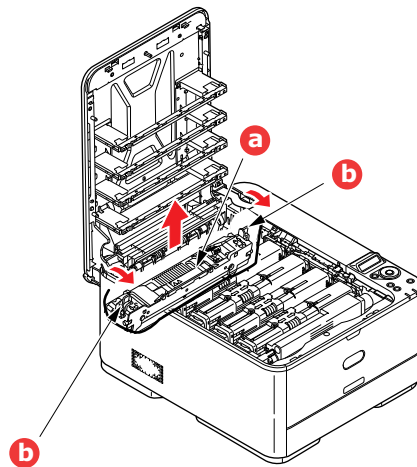

3. Pull the two fuser retaining levers (b) towards the front of the printer so that they are fully upright.
4. Holding the fuser by its handle (a), lift the fuser straight up and out of the printer. If the fuser is still warm, place it on a flat surface which will not be damaged by heat.
5. Remove the new fuser from its packaging and remove the transit material.
6. Holding the new fuser by its handle, make sure that it is the correct way round. The retaining levers (b) should be fully upright, and the two locating lugs (c) should be towards you.

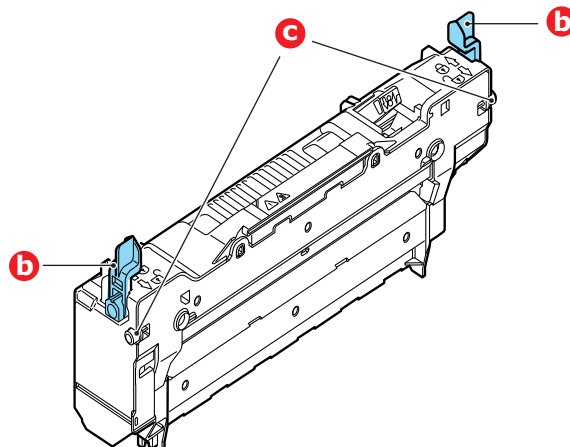

7. Lower the fuser into the printer, locating the two lugs (c) into their slots in the sides of the printer cavity.

8. Push the two retaining levers (b) towards the rear of the printer to lock the fuser in place.

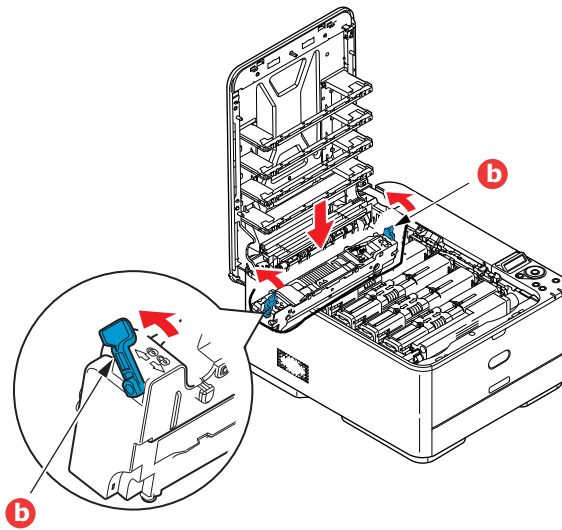

9. Finally, close output tray and press down firmly at both sides so that the cover latches closed.

## CLEANING

### CAUTION!

**Use a clean, moist, lint-free cloth for cleaning. Do not use benzene, thinners or alcohol as a cleaning agent.**

#### ...THE UNIT CASING

1. Switch the printer off.
2. Wipe the unit surface with a soft cloth moistened sparingly with water or neutral detergent.

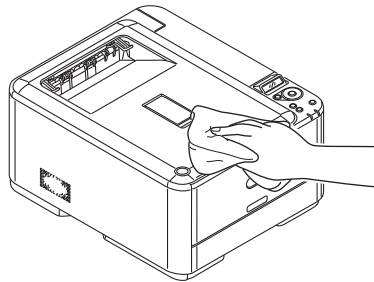

3. Use a soft dry cloth to dry the unit surface.
4. Switch the printer on.

#### ...THE LED HEAD

Clean the LED heads when printing does not come out clearly, has white lines or when text is blurred.

There is no need to switch off the printer to clean the lens.

1. Press the cover release and open the printer's output tray fully.
2. Gently wipe the LED head surface with a clean, lint free cloth.

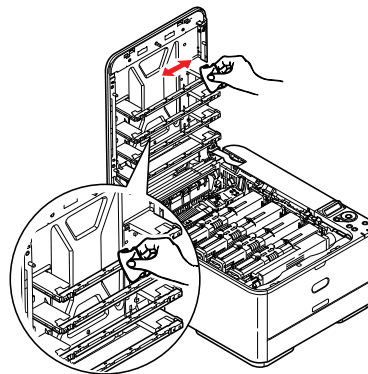

### CAUTION!

**Do not use methyl alcohol or other solvents on the LED head as damage to the lens surface will occur.**

3. Close output tray and press down firmly at both sides so that the cover latches closed.

## INSTALLING UPGRADES

This section explains how to install optional equipment into your printer. This includes:

- > Additional paper tray
- > Wireless LAN Module

### ADDITIONAL PAPER TRAY

1. Switch the printer off and disconnect the AC power cable.
2. Place additional paper tray on desired location.
3. Observing safety rules for lifting and, using locating guides, place printer on top of the additional paper tray.

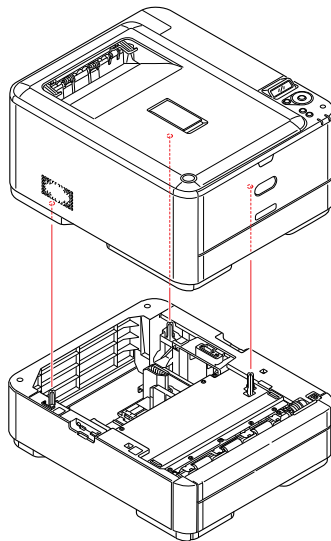

Model Number: N34311A

4. Fit retaining clips as shown.

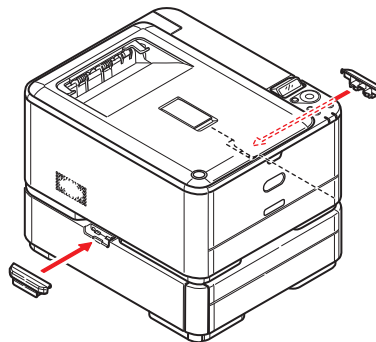

5. Re-connect the AC power cable and switch the printer ON.  
All that remains is to adjust the printer driver to make full use of the new features (["Setting the driver device options" on page 64](#)).

## SETTING THE DRIVER DEVICE OPTIONS

Once your new upgrade has been installed, you may need to update the printer driver so that the additional features are available to your applications.

Accessories such as additional paper trays will only be usable if the printer driver on your computer knows they are there.

In some cases the hardware configuration of your machine is automatically detected when the driver is installed. However, it is advisable to at least check whether all of the available hardware features are listed in the driver.

This procedure is essential if you subsequently add extra hardware features to your machine after the drivers have been installed and set up.

Remember that if your machine is shared between users on different computers, the driver must be adjusted on each user's machine.

### Windows

1. Access the driver's Properties window.
  - (a) Open the Device and Printers window via the Start Menu or from the Windows Control Panel.
  - (b) Right-click the icon for this machine, and choose **Printer Properties** from the pop-up menu.
2. Select the **Device Options** tab.

In the Windows PostScript driver the tab may be called **Device Settings**.
3. Set the options for any devices you have just installed.
4. Click **OK** to close the window and save your changes.

### Mac OS X

---

*NOTE*  
*Applies to the PS driver only.*

---

1. Select **System Preference** from the **Apple Menu**. Open the Mac OS X **Printers & Scanners** Preferences.
2. Ensure your machine is selected.
3. Click **Options & Supplies**.
4. Click **Options**.
5. Select all hardware options appropriate to your machine and click **OK**.



## WIRELESS LAN MODULE

### PRECAUTIONS WHEN USING WIRELESS LAN

Carefully read the following precautions before using the machine in a wireless LAN environment.

- In a wireless LAN environment, the machine enters sleep mode, but does not enter deep sleep mode.
- Do not place any devices (especially microwave ovens or digital cordless telephones) that emit weak electromagnetic waves near the machine.
- Install the machine near a wireless LAN access point or wireless device with no obstacles between them (the distance should be within 30m).
- Wireless connections may be difficult if there is any metal, aluminum framed windows, or reinforced concrete walls between the machine and the wireless LAN access point.
- Wireless LAN connections may have slower transmission speeds, depending on the environment, than wired LAN or USB connections. We recommend using a wired LAN or a USB connection to print large amounts of data, such as photographs.

1. Switch off the printer.
2. Open the Wireless LAN I/F Cover.
3. Connect the connector of the connection cable to the Wireless LAN module.
4. Install the module to the printer.
5. Close the Wireless LAN I/F Cover.
6. Press and hold the **OK** button on the operator panel while turning on the printer, and release it once **BOOT MENU** appears on the display panel.
7. Press the **OK** button.
8. Enter the Admin password, and then press the **OK** button.
9. Press **up** or **down** on the operator panel to display **WIRELESS MODULE**.
10. Press the **OK** button.
11. Press the **up** button, select **ENABLE**, and press the **OK** button.
12. Press the **ON LINE** button.

### CONNECTING VIA WIRELESS LAN (INFRASTRUCTURE MODE)

To choose a valid default gateway.

1. Press **up** or **down** on the operator panel to display **ADMIN SETUP**.
2. Press the **OK** button.
3. Enter the Admin password, and then press the **OK** button.
4. Press **up** or **down** on the operator panel to display **NETWORK SETUP**, and then press the **OK** button.
5. Press **up** or **down** on the operator panel to display **ENABLING DEFAULT GATEWAY**, and then press the **OK** button.
6. Press **down** on the operator panel to display **WIRELESS (INFRASTRUCTURE)**, and then press the **OK** button.

## Connecting Using WPS

If the wireless LAN access point supports WPS, the connection to the wireless LAN can be made easily by using the easy setup button (WPS button).

Follow the procedure below for the setup.

1. Confirm the position of the easy setup button and when to press the button by referring to the user manual of the wireless LAN access point.
2. Confirm that the wireless LAN access point has been activated and is functioning normally.
3. Turn on the printer.  
When **SETUP WIRELESS?** appears, select **YES**. Proceed to Step 6.
4. Press **up** or **down** on the operator panel to display **WIRELESS(INFRASTRUCTURE) SETTING**, and then press the **OK** button.
5. Enter the Admin password, and then press the **OK** button.  
(The default password is 999999.)
6. Press **up** on the operator panel to select **ENABLE**, and then press the **OK** button.
7. Press **up** or **down** on the operator panel to display **WPS SETUP**, and then press the **OK** button.
8. Select **WPS-PBC**, and then press the **OK** button.
9. Select **YES**, and then press the **OK** button.
10. The Printer starts searching for wireless LAN access points. During 2 minutes, press the easy setup button for the wireless LAN access point for a few seconds.

Once the setup completion screen is displayed, it indicates that the wireless LAN setup has completed.

## Set the IP Address

Set a different IP address for the wireless LAN from that of the wired LAN. Enter the setting menu and make the settings by the following procedure.

1. Press **up** or **down** on the operator panel to display **WIRELESS(INFRASTRUCTURE) SETTING**, and then press the **Enter** button.
2. Enter the Admin password and then press the **OK** button.  
(The default password is 999999.)
3. Press **up** or **down** on the operator panel to display **NETWORK SETTING**.
4. **AUTO** or **MANUAL** in the **IP ADDRESS SET**.  
If **MANUAL** is selected, manually input the IPv4 Address, Subnet Mask and Gateway Address.

## CONNECTING VIA WIRELESS LAN (AP MODE)

### Automatic Setup (Push Button)

If the wireless terminal (computer, tablet, smartphone, etc.) supports WPS-PBC (push button), then you can use the WPS button to connect via wireless (AP mode).

Follow the procedure below to connect.

1. Confirm the position of the WPS button in the user's manual provided with the wireless terminal (computer, tablet, smartphone, etc.).
2. Turn on the printer.  
When **SETUP WIRELESS?** appears, select **NO**.
3. Press **up** or **down** on the operator panel to display **WIRELESS (AP MODE) SETTING**, and then press the **OK** button.
4. Enter the Admin password, and then press the **OK** button.  
(The default password is 999999.)
5. Select **ENABLE**, and then press the **OK** button.
6. Press **up** or **down** on the operator panel to display **AUTOMATIC SETUP (PUSHBUTTON)**, and then press the **OK** button.
7. Select **YES**, and then press the **OK** button.
8. Start WPS-PBC (push button) on the wireless terminal (computer, tablet, smartphone, etc.).

Once the setup completion screen is displayed, it indicates that the wireless LAN setup has completed.

## TROUBLESHOOTING

Provided that you follow the recommendations in this guide on the use of print media, and you keep the media in good condition prior to use, your printer should give years of reliable service. However, paper jams occasionally do occur, and this section explains how to clear them quickly and simply.

Jams can occur due to paper misfeeding from a paper tray or at any point on the paper path through the printer. When a jam occurs, the printer immediately stops, and the Attention LED on the control panel informs you of the event. If printing multiple pages (or copies), do not assume that, having cleared an obvious sheet, others will not also be stopped somewhere along the path. These must also be removed in order to clear the jam fully and restore normal operation.

### MAJOR PRINTER COMPONENTS AND PAPER PATH

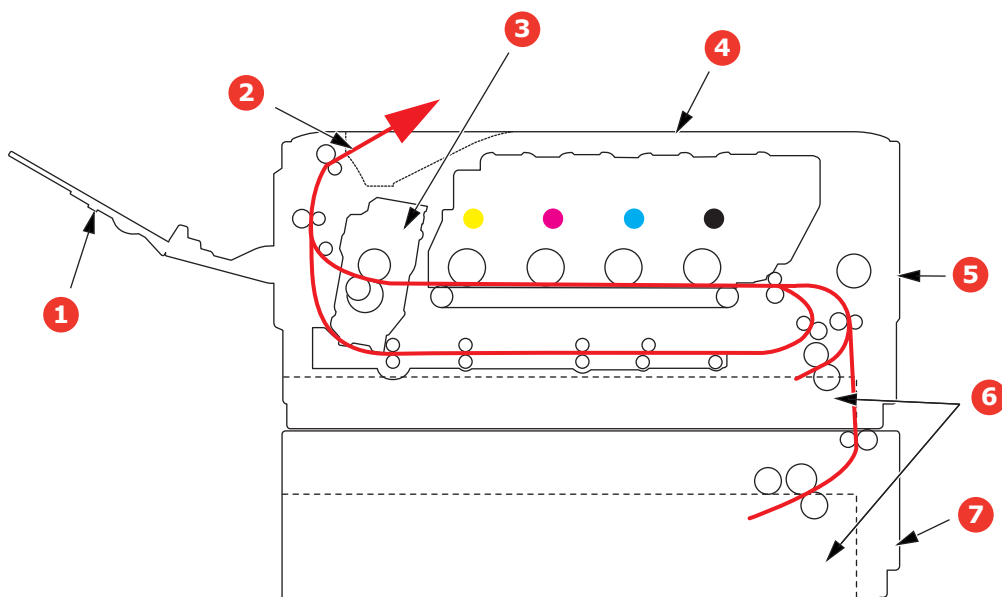

- |                      |                                       |
|----------------------|---------------------------------------|
| 1. Rear output tray. | 5. MP tray.                           |
| 2. Paper exit.       | 6. Paper tray.                        |
| 3. Fuser unit.       | 7. Additional paper tray (if fitted). |
| 4. Output tray.      |                                       |

## PAPER SENSOR ERROR CODES

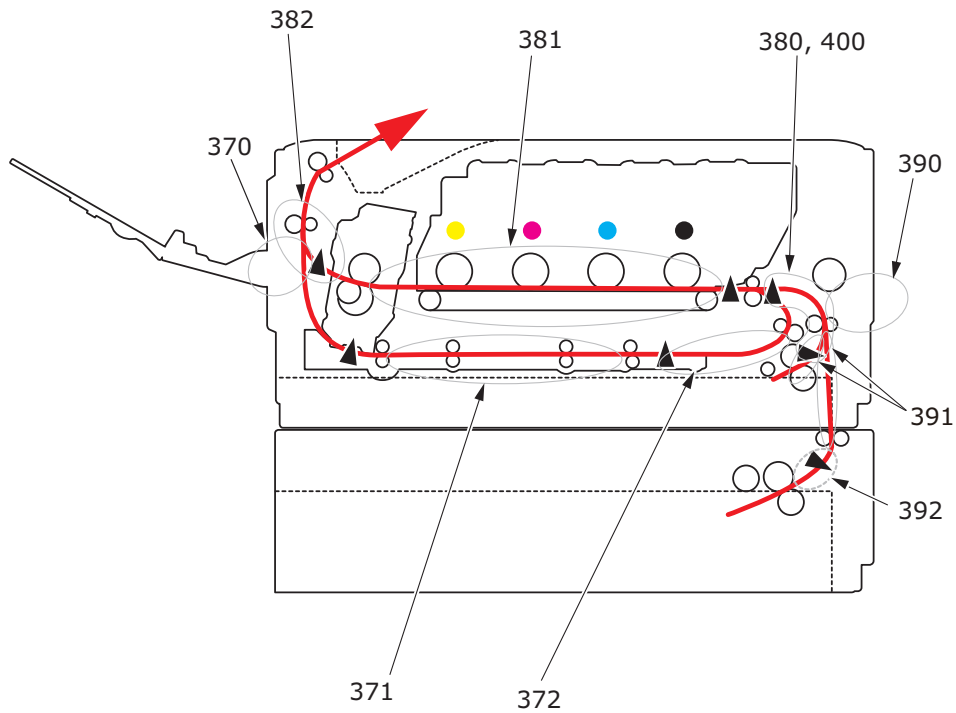

CODE #	LOCATION	CODE #	LOCATION
370	Duplex	390	MP tray
371	Duplex	391	Paper tray
372	Duplex	392	2 <sup>nd</sup> Paper tray <sup>a</sup>
380	Paper feed	400	Paper size
381	Paper path	409	Rear output tray (sensor not shown)
382	Paper exit		

a. If fitted.

## CLEARING PAPER JAMS

1. If a sheet is well advanced out of the top of the printer, simply grip it and pull gently to draw it fully out. If it does not remove easily, do not use excessive force. It can be removed from the rear later.
2. Press the cover release and open the printer's output tray fully.

### WARNING!

**If the printer has been powered on, the fuser will be hot. This area is clearly labelled. Do not touch.**

3. Holding it by its handles, lift the image drum assembly, complete with the toner cartridges, up and out of the printer.

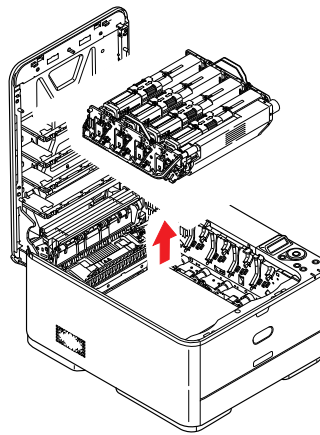

4. Put the assembly down gently onto a piece of paper to prevent toner from marking your furniture and to avoid damaging the green drum surface, and cover.

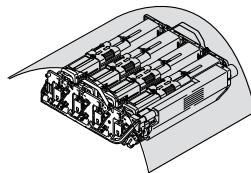

### CAUTION!

**The green image drum surface at the base of the Image Drum is very delicate and light sensitive. Do not touch it and do not expose it to normal room light for more than 5 minutes. If the drum unit needs to be out of the printer for longer than this, please wrap the cartridge inside a black plastic bag to keep it away from light. Never expose the drum to direct sunlight or very bright room lighting.**

5. Look into the printer to check whether any sheets of paper are visible on any part of the belt unit.

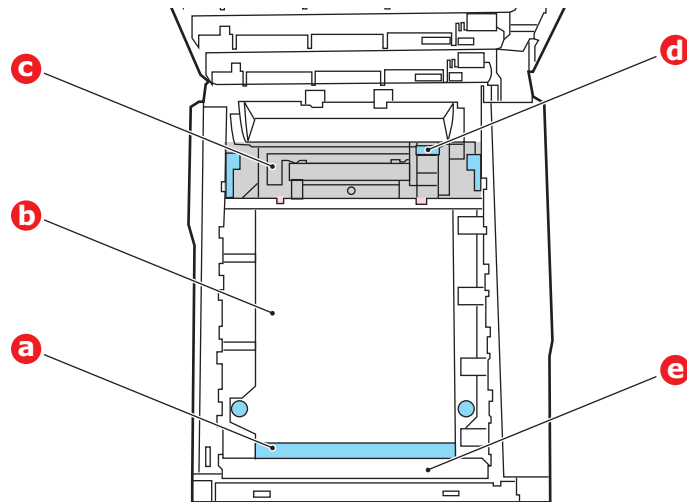

### CAUTION!

**Do not use any sharp or abrasive objects to separate sheets from the belt. This may damage the belt surface.**

- (a) To remove a sheet with its leading edge at the front of the belt (a), lift the plastic guard (e) at the front of the printer, then carefully lift the sheet from the belt and pull it forwards into the internal drum cavity and withdraw the sheet.

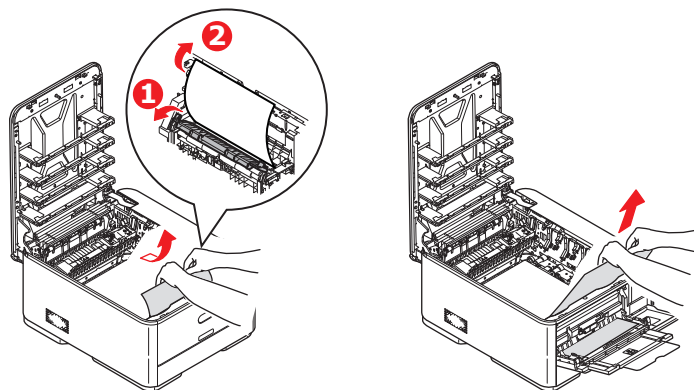

- (b) To remove a sheet from the central area of the belt (b), carefully separate the sheet from the belt surface and withdraw the sheet.

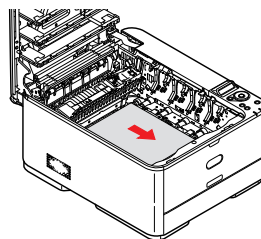

- (c) To remove a sheet just entering the fuser (c), separate the trailing edge of the sheet from the belt, push the fuser pressure release lever (d) towards the front and down to release the fuser's grip on the sheet, and withdraw the sheet

through the drum cavity area. Then allow the pressure release lever to rise again.

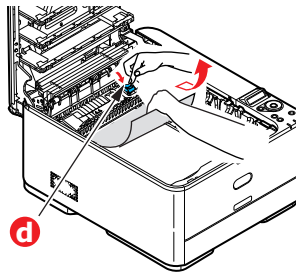

---

**NOTE**

*If the sheet is well advanced into the fuser (only a short length is still visible), do not attempt to pull it back.*

---

- (d) To remove a sheet in the fuser, move the two retaining levers (e) towards the front of the machine to release the fuser. Withdraw the fuser unit using the handle (f).

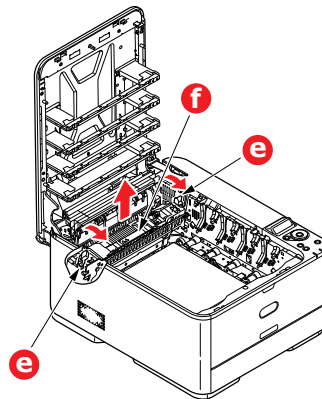

- (e) Press release lever (g) and pull the trapped paper from the fuser.

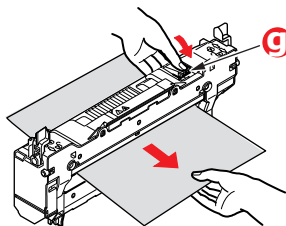

- (f) Replace fuser unit into the machine and move locking levers (e) toward the rear of the machine.

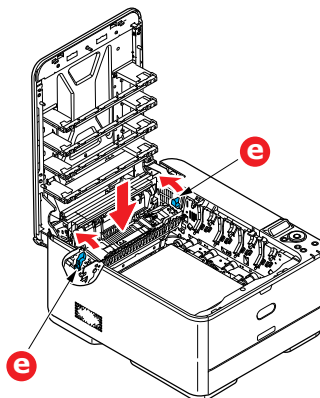



- 6.** If you were duplex printing when the jam occurred, check the duplex paper path:
- (a) Pull the locking levers at each side of the transfer belt up and towards the front of the machine.

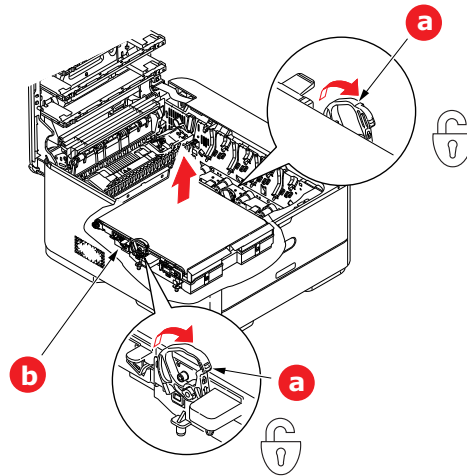

- (b) Using the locking levers (a), lift the belt (b) upwards and withdraw from the machine.
- (c) Look into the printer to check whether any sheets of paper are visible on any part of the paper path. Pull out any sheets found in this area.
- (d) Lower the belt unit into place, with the drive gear towards the rear of the printer. Locate the drive gear into the gear inside the printer by the rear right corner of the unit, and lower the belt unit flat inside the printer.

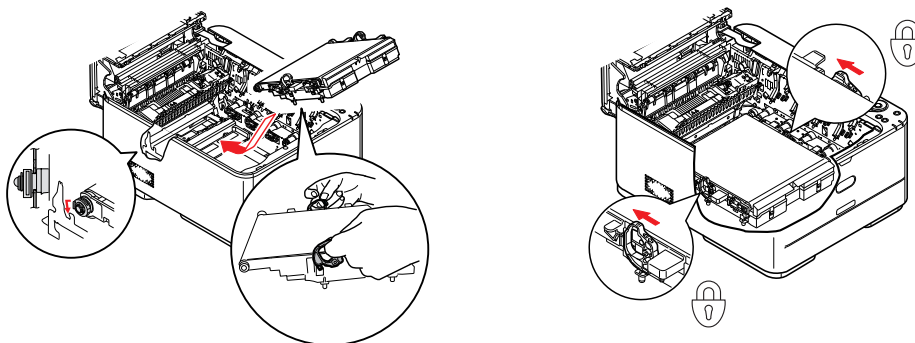

- (e) Push the locking levers towards the rear of the machine. This will secure the belt unit in place.
- 7.** Holding the image drum assembly by its handles, lower it into place in the machine, locating the pegs at the sides into their slots in the sides of the printer cavity.

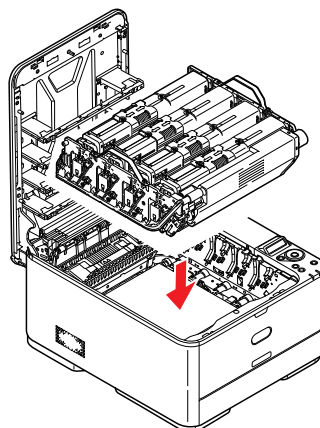

8. Lower output tray but do not press down to latch it closed yet. This will protect the drum from excessive exposure to room lighting while you check the remaining areas for jammed sheets.
9. Open rear output tray (h) and check for a sheet of paper in the rear path area (i).

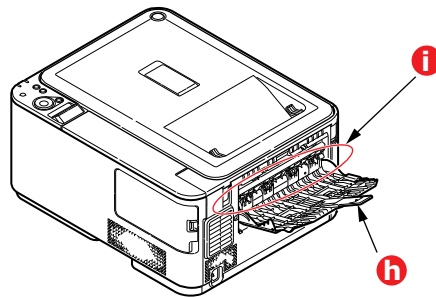

- > Pull out any sheets found in this area.
- > If the sheet is low down in this area and difficult to remove, it is probably still gripped by the fuser. In this case raise output tray, reach around and press down on the fuser pressure release lever (d).

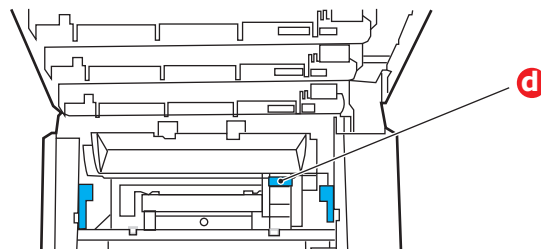

10. If you are not using the rear exit tray, close it once any paper has been removed from this area.
11. Pull out the paper tray and ensure that all paper is stacked properly, is undamaged, and that the paper guides are properly positioned against the edges of the paper stack. When satisfied, replace the tray.

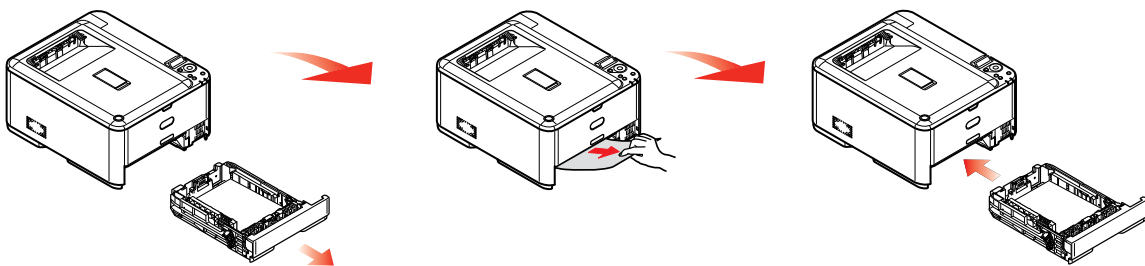

12. Finally, close output tray and press down firmly so that the cover latches closed.
- When the jam has been cleared, if **JAM RECOVERY** is set to **ON** in the **SYSTEM ADJUST**, the printer will attempt to reprint any pages lost due to paper jams.

## DEALING WITH UNSATISFACTORY PRINTING

SYMPTOMS	POSSIBLE CAUSES	STEPS TO TAKE
Vertical white lines can be seen on the printed page.	The LED head is dirty.	Wipe the LED head with a soft, lint-free cloth.
	The toner is low.	Open output tray and tap the cartridge a few times to evenly distribute any remaining toner. If symptoms persist, replace the toner cartridge.
	Foreign materials may be present in the image drum.	Replace the image drum cartridge.
	Light-shielding film of the image drum cartridge is dirty.	Wipe the film with a soft, lint-free cloth.
Printed images are fading vertically.	The LED head is dirty.	Wipe the LED head with a soft, lint-free cloth.
	The toner is low.	Open output tray and tap the cartridge a few times to evenly distribute any remaining toner. If symptoms persist, replace the toner cartridge.
	The paper is not suitable for the printer unit.	Use recommended paper.
Printing is light.	The toner cartridge is not properly seated.	Reinstall the toner cartridge.
	The toner is low.	Open output tray and tap the cartridge a few times to evenly distribute any remaining toner. If symptoms persist, replace the toner cartridge.
	The paper is moist.	Use paper stored in proper temperature and humidity conditions.
	The paper is not suitable for the printer unit.	Use recommended paper.
	Thickness and type of paper are inappropriate.	Set the correct value of media type and media weight in the Media menu or set one value thicker for media weight.
	Recycled paper is being used.	Set one value thicker for media weight in the Media menu.
Partially faded images. White spots and lines appear in solid printing.	Paper is moist or dry.	Use paper stored in proper temperature and humidity conditions.
Vertical lines appear.	The image drum cartridge is damaged.	Replace the image drum cartridge.
	The toner is low.	Open output tray and tap the cartridge a few times to evenly distribute any remaining toner. If symptoms persist, replace the toner cartridge.

SYMPTOMS	POSSIBLE CAUSES	STEPS TO TAKE
Horizontal Lines and spots appear periodically.	When the interval is about 94mm (4in), the image drum (the green tube) is damaged or dirty.	Wipe it lightly with a soft cloth. Replace the image drum cartridge when it is damaged.
	When the interval is about 30mm (1.2in), there may be foreign particles in the image drum cartridge.	Open/close output tray, and print again.
	When the interval is about 86mm (3.4in), the fuser unit is damaged.	Replace the fuser unit.
	The image drum cartridge has been exposed to light.	Replace the image drum cartridge if the problem is not resolved.
White area of paper is lightly stained.	Paper contains static.	Use paper stored in proper temperature and humidity conditions.
	Too thick paper is used.	Use thinner paper.
	The toner is low.	Open output tray and tap the cartridge a few times to evenly distribute any remaining toner. If symptoms persist, replace the toner cartridge.
Periphery of the letters is smudged.	The LED head is dirty.	Wipe the LED head with a soft, lint-free cloth.
Toner comes off when it is rubbed.	The thickness and type of the paper are incorrectly set.	Set the correct value of media type and media weight in the Media menu or set one value lighter for media weight.
	Recycled paper is used.	Set one value thicker for media weight in the Media menu.
Glossiness is not uniform.	The thickness and type of the paper are incorrectly set.	Set the correct value of media type and media weight in the Media menu or set one value lighter for media weight.

When the error message "**UNKNOWN CONSUMABLE**" is displayed, you can use any consumables in your product, but you must accept the risks of using non-genuine consumables. If the use of non-genuine consumables causes damage to the product or results in your product not functioning to its full specification, then such damage or effect on the product is not covered by warranty. To accept these risks and to restore function;

1. Turn off your product.
2. Press and hold the **CANCEL** button and turn your product on.
3. After start up, release the **CANCEL** button.

---

*NOTE*

*This operation will be recorded for future reference.*

---

## BEFORE MACHINE DISPOSAL

Before this machine is disposed of, it is recommended to erase the registered privacy data and the stored data.

The data stored in the machine is shown below.

- > Admin password
  - > Registered settings in various menus
  - > Various records
  - > Access control, user management data (local user, external user cache **LDAP**, and **Kerberos**)
1. Press the ▲ button on the operator panel.
  2. Press the scroll button ▼ to select **ADMIN SETUP**, and press the **OK** button.
  3. Input the admin password.
  4. Select **OTHERS SETUP > ERASE PRIVACY DATA**.
  5. Once **ARE YOU SURE?** is displayed, select **YES**, and press the **OK** button.
  6. Once **WOULD YOU LIKE REALLY?** is displayed, select **YES**, and press the **OK** button. Restart the machine to erase the data.

---

### NOTE

*Once the action is executed, the erased data cannot be restored. To cancel the erasing, select **NO** in Step 5 or Step 6.*

---

# SPECIFICATIONS

## C332 - N34342A , N34342B

ITEM	SPECIFICATION
Dimensions	410 x 504 x 242mm (W x D x H)
Weight	21Kg approx.
Power supply	N34342A: 110 to 127VAC @ 50/60 Hz ± 2% N34342B: 220 to 240VAC @ 50/60 Hz ± 2%
Operating environment	Operating 10 to 32 °C/20 to 80% RH (optimum 25 °C wet, 2 °C dry) Off: 0 to 43 °C/10 to 90% RH (optimum 26.8 °C wet, 2 °C dry)
Print environment	Color 17 to 27 °C @ 50 to 70% RH

# INDEX

## B

- Belt  
how to replace ..... 58

## C

- Cleaning the LED head ..... 62

## D

- Duplex  
paper size and  
weight limits ..... 14

## E

- Envelopes  
loading ..... 18

## F

- Fuser  
how to replace ..... 60

## G

- Getting Started ..... 9

## M

- Major printer components and  
paper path ..... 68
- Menu functions ..... 20
- Menus  
administrator menu ..... 35  
factory default settings ..... 22  
how to use ..... 20  
information menu ..... 25  
maintenance  
menu ..... 26, 37, 40, 41,  
42, 43, 44, 45, 46, 47, 48, 49  
menu map ..... 25  
print statistics menu ..... 49  
system adjust menu ..... 36, 37
- Multi purpose tray  
how to use ..... 18  
paper metrics ..... 14

## O

- Operator Panel ..... 20

## P

- Paper  
jam clearing ..... 68  
jam, error codes ..... 69  
loading cassette trays ..... 15  
loading letterhead ..... 16  
recommended types ..... 12  
supported sheet sizes ..... 13
- Problem checklist  
unsatisfactory printing ..... 75

## T

- Toner  
how to replace ..... 54

## U

- Upgrades  
additional paper tray ..... 63

## OKI CONTACT DETAILS

### **OKI Systems (UK) Ltd.**

Blays House  
Wick Road  
Egham  
Surrey  
TW20 0HJ  
Tel: +44 (0) 1784 274300  
Website: www.oki.com/uk

### **OKI Systems (Ireland) Ltd**

A7 Calmount Park  
Ballymount  
Dublin 12  
D12 TX94  
Ireland  
Tel: +353 (0) 1 4049590  
Fax: +353 (0) 1 4049591  
Website: www.oki.com/ie

### **OKI Systems (Czech and Slovak), s.r.o.**

Futurama Business Park -  
Sokolovská 651/136A  
186 00 Praha 8  
Czech Republic  
Tel: +420 224 890158  
Fax: +420 22 232 6621  
Website: www.oki.cz, www.oki.sk

### **Oki Systems (Deutschland) GmbH**

Hansaallee 187  
40549 Düsseldorf  
Tel: +49 (0) 211 / 5266-0  
Fax: +49 (0) 211 59 33 45  
Website: www.oki.de

Albania, Bosnia, Bulgaria, Croatia,  
Cyprus, Estonia, Greece, Israel,  
Latvia, Lithuania, Macedonia,  
Romania, Serbia, Slovenia

### **CEE Export Group: OKI Systems (Poland) Sp. z o.o.**

Platinum Business Park 2, 3rd Floor  
ul. Domaniewska 42, 02-672 Warsaw  
Poland  
Tel: +48 (0) 22 448 65 00  
Fax: +48 (0) 22 448 65 0  
Website: www.oki.pl

### **Oki Systèmes (France) S.A.**

Zone Silic - Immeuble Osaka  
21 rue du Jura  
CS 90277  
94633 RUNGIS Cedex  
Paris  
Tél: Standard 0820 200 410  
(0.09€/min depuis une ligne fixe\*)  
Hotline 01 76 54 21 50 (n° non  
surtaxé)  
Website: www.oki.fr

### **OKI Systems (Magyarország) Kft.**

H-1133 Budapest,  
Váci út 76  
Hungary  
Telefon: +36 1 814 8000  
Telefax: +36 1 814 8009  
Website: www.okihu.hu

### **OKI Systems (Italia) S.p.A.**

via Milano, 11,  
20084 Lacchiarella (MI)  
Tel: +39 (0) 2 900261  
Fax: +39 (0) 2 90026344  
Website: www.oki.it

### **OKI Systems (Polska) Sp. z o.o**

Platinum Business Park II, 3rd  
Floor  
ul. Domaniewska 42  
02-672 Warsaw  
Poland  
Tel: +48 22 448 65 00  
Fax: +48 22 448 65 01  
Website: www.oki.pl  
E-mail: oki@oki.com.pl  
Hotline: 0800 120066  
E-mail: tech@oki.com.pl

### **OKI Europe Limited, Sucursal em Portugal**

Av. Quinta Grande 53  
7º D Alfragide  
2614-521 Amadora  
Portugal  
Tel: +351 21 470 4200  
Fax: +351 21 470 4201  
Website: www.oki.pt  
E-mail : oki@oki.pt

### **Oki Service Serviço de apoio técnico ao Cliente**

Tel: 214 727 660  
E-mail : okiserv@oki.pt

### **OKI Systems Rus, LLC (Russia)**

Sector B, 3rd Floor, Svyatogor-4  
Business Center10/4, Letnikovskaya  
str.115114, Moscow  
Tel: +7 495 276 5060  
Fax: +7 495 258 6070  
e-mail: info@oki.ru  
Website: www.oki.ru  
Technical support:  
Tel: +7 495 564 8421  
e-mail: tech@oki.ru

### **Oki Systems (Österreich)**

Campus 21  
Businesszentrum Wien Sued  
Liebermannstrasse A02 603  
22345 Brun am Gebirge  
Tel: +43 223 6677 110  
Service-Hotline:  
+43 (0) 2236/677 110-501  
Website: www.oki.at

### **OKI Europe Ltd. (Ukraine)**

Raisy Opkinoy Street,8  
Building B, 2<sup>nd</sup> Floor,  
Kiev 02002  
Ukraine  
Tel: +380 44 537 5288  
e-mail: event@oki.ua  
Website: www.oki.ua

### **OKI Sistem ve Yazıcı Çözümleri Tic. Ltd. Şti.**

Harman sok Duran Is Merkezi,  
No:4, Kat:6,  
34394, Levent  
İstanbul  
Tel: +90 212 279 2393  
Faks: +90 212 279 2366  
Web: www.oki.com.tr

### **Oki Systems (Belgium)**

Medialaan 24  
1800 Vilvoorde  
Helpdesk: 02-2574620  
Fax: 02 2531848  
Website: www.oki.be

### **OKI Systems (Danmark) a/s**

Herstedøstervej 27  
2620 Albertslund  
Danmark  
Adm.: +45 43 66 65 00  
Fax: +45 43 66 65 90  
E-mail: salg@oki.dk /  
support@oki.dk  
Website: www.oki.dk

### **OKI Europe Limited, Sucursal en España**

Complejo Vega Norte. C/ Anabel  
Segura, 16. Edif. 3 – 4º Plta.  
28.108, Alcobendas  
Madrid  
Tel +34 91 343 16 20  
Website: www.oki.es



**OKI Middle East, India and Sub Sahara Africa**

Building 7W A  
Office 2008,  
Dubai Airport Free Zone  
PO Box 54604  
Dubai, UAE

Tel: +971 4 204 5810  
Website: [www.oki.com/me](http://www.oki.com/me)

**OKI Systems (Finland) Oy**

Vänrikinkuja 3  
02600 Espoo

Tel: +358 (0) 207 900 800  
Fax: +358 (0) 207 900 809  
Website: [www.oki.fi](http://www.oki.fi)

**OKI Systems (Holland) b.v.**

Neptunstraat 27-29  
2132 JA Hoofddorp

Helpdesk: 0800 5667654  
Tel: +31 (0) 23 55 63 740  
Fax: +31 (0) 23 55 63 750  
Website: [www.oki.nl](http://www.oki.nl)

**OKI Systems (Norway) AS**

Tevlingveien 23  
N-1081 Oslo

Tel: +47 (0) 63 89 36 00  
Telefax: +47 (0) 63 89 36 01  
Website: [www.oki.no](http://www.oki.no)

Var vänlig kontakta din  
Återförsäljare i första hand, för  
konsultation. I andra hand kontakta

**OKI Systems (Sweden) AB**

Box 1193  
164 26 Kista

Tel. +46 (0) 8 634 37 00  
e-mail: [info@oki.se](mailto:info@oki.se)  
Website: [www.oki.se](http://www.oki.se)

**OKI Systems (Schweiz)**

Baslerstrasse 15  
CH-4310 Rheinfelden

Support deutsch +41 61 827 94 81  
Support français +41 61 827 94 82  
Support italiano +41 061 827 9473

Tel: +41 61 827 9494  
Website: [www.oki.ch](http://www.oki.ch)

**OKI Data Americas Inc.(United States • États-Unis)**

2000 Bishops Gate Blvd.  
Mt. Laurel, NJ 08054  
USA

Tel: 1-800-654-3282  
Fax: 1-856-222-5247  
<http://WWW.OKIPRINTINGSOLUTIONS.COM>  
<http://my.okidata.com>

8505 Freeport Pkwy  
Suite 100  
Irving, TX 75063  
<http://www.okidata.com>

2067 Wineridge Place  
Suite C & D  
Escondido, CA 92029

Phone: 760-781-5200  
Toll Free: 800-264-1272  
<http://www.okidata.com/wide-format>

**OKI Data Americas Inc.(Canada • Canadá)**

4140B Sladeview Crescent Unit 7 & 8  
Mississauga, Ontario  
Canada L5L 6A1

Tél: 1-905-608-5000  
Télé: 1-905-608-5040  
<http://WWW.OKIPRINTINGSOLUTIONS.COM>

**OKI Data Americas Inc.(América Latina (OTRO))**

2000 Bishops Gate Blvd.  
Mt. Laurel, NJ 08054  
USA

Tel (Español): 1-856-222-7496  
1-856-222-5276  
Fax: 1-856-222-5260  
Email: [LASatisfaction@okidata.com](mailto:LASatisfaction@okidata.com)

**OKI Data de Mexico, S.A. de C.V.**

Mariano Escobedo #748, Piso 8  
Col. Nueva Anzures  
C.P. 11590, México, D.F.

Tel: 52-555-263-8780  
Fax: 52-555-250-3501  
<http://WWW.OKIPRINTINGSOLUTIONS.COM>

**OKI Data do Brasil Informática Ltda.**

Av. Alfredo Egídio de Souza Aranha,  
100 - 5º Andar - Bloco C  
Chácara Santo Antonio - São Paulo,  
SP - Brasil  
CEP: 04726-170

Tel: 55-11-3543-5500  
Fax: 55-11-3444-3501  
email: [okidata@okidata.com.br](mailto:okidata@okidata.com.br)  
[HTTP://www.okiprintingsolutions.com](http://www.okiprintingsolutions.com)

**Argentina/Chile/Paraguay/Perú/Uruguay**

**OKI Data Americas, Inc.**

Sucursal Argentina  
Ugarte 3610 Piso 4º(1605) Olivos  
Buenos Aires, Argentina

TEL: +54 11 5288 7500  
Fax: +54 11 5288 7599

**Colombia/Ecuador/Venezuela/Centroamérica y Caribe**  
**OKI Data Americas, Inc.**

Sucursal Colombia  
Carrera 13 #97-51, Oficina 101  
Bogotá Colombia

TEL: +57 1 704 5159

**OKI Data (Singapore) Pte. Ltd.**

438A Alexandra Road #02-11/12,  
Lobby 3, Alexandra Technopark  
Singapore(119967)

Tel: (65) 6221 3722  
Fax: (65) 6594 0609  
<http://www.okidata.com.sg>

**OKI Systems (Thailand) Ltd.**

1168/32 Lumpini Tower,  
16th Floor, Rama IV Road,  
Tungmahamek, Sathorn  
Bangkok 10120

Tel: (662) 679 9235  
Fax: (662) 679 9243/245  
<http://www.okisysthai.com>

**OKI Data(Australia) Pty Ltd.**

Level1 67 Epping Road, Macquarie  
Park  
NSW 2113, Australia

Tel: +61 2 8071 0000  
(Support Tel: 1800 807 472)  
Fax: +61 2 8071 0010  
<http://www.oki.com.au>

**OKI Data New Zealand**

8 Antares Place Rosedale,  
Auckland, 0632 New Zealand

Tel: (64) 9 477 0500  
(Customer Support: 0800 778 800)  
Fax: (64) 9 477 0549  
<http://www.oki.co.nz/>

**OKI Data(S) P Ltd. Malaysia Rep Office**

Suite 21.03, 21st Floor Menara IGB,  
Mid Valley City,  
Lingkaran Syed Pura 59200,  
Kuala Lumpur, Malaysia

Tel: (60) 3 2287 1177  
Fax: (60) 3 2287 1166

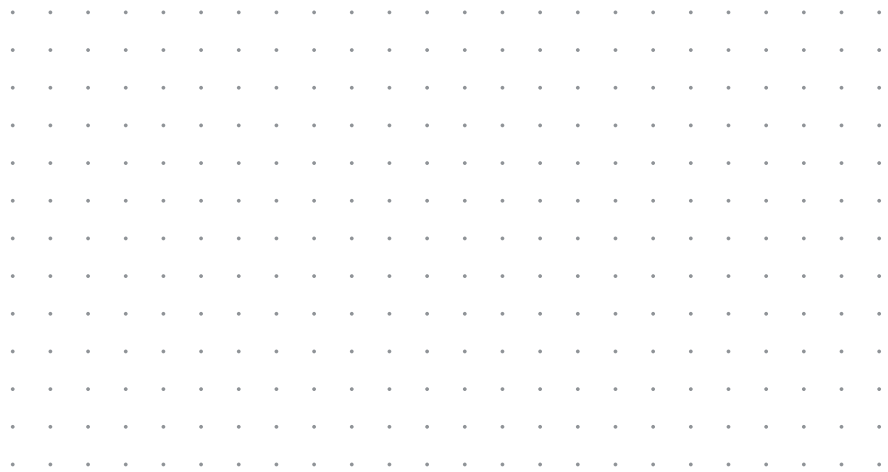

**Oki Data Corporation**  
4-11-22 Shibaura, Minato-ku, Tokyo  
108-8551, Japan