



FS-1030MPF

FS-1030MFP/DP

FS-1035MFP/DP

FS-1130MFP

FS-1135MFP

**SERVICE
MANUAL**

Published in August 2011
842MH110
2MHSM060
First Edition

CAUTION

RISK OF EXPLOSION IF BATTERY IS REPLACED BY AN INCORRECT TYPE. DISPOSE OF USED BATTERIES ACCORDING TO THE INSTRUCTIONS.

It may be illegal to dispose of this battery into the municipal waste stream. Check with your local solid waste officials for details in your area for proper disposal.

ATTENTION

IL Y A UN RISQUE D'EXPLOSION SI LA BATTERIE EST REMPLACÉE PAR UN MODÈLE DE TYPE INCORRECT. METTRE AU REBUT LES BATTERIES UTILISÉES SELON LES INSTRUCTIONS DONNÉES.

Il peut être illégal de jeter les batteries dans des eaux d'égout municipales. Vérifiez avec les fonctionnaires municipaux de votre région pour les détails concernant des déchets solides et une mise au rebut appropriée.

Notation of products in the manual

For the purpose of this service manual, products are identified by print speed, and presence of FAX.

FS-1030MFP : 3in1 model by 30ppm (without FAX and document processor)

FS-1030MFP/DP : 3in1 model by 30ppm (without FAX)

FS-1035MFP/DP : 3in1 model by 35ppm (without FAX)

FS-1130MFP : 4in1 model by 30ppm (with FAX)

FS-1135MFP: : 4in1 model by 35ppm (with FAX)

Revision history

Revision	Date	Replaced pages	Remarks

This page is intentionally left blank.

Safety precautions

This booklet provides safety warnings and precautions for our service personnel to ensure the safety of their customers, their machines as well as themselves during maintenance activities. Service personnel are advised to read this booklet carefully to familiarize themselves with the warnings and precautions described here before engaging in maintenance activities.

Safety warnings and precautions

Various symbols are used to protect our service personnel and customers from physical danger and to prevent damage to their property. These symbols are described below:

 **DANGER:** High risk of serious bodily injury or death may result from insufficient attention to or incorrect compliance with warning messages using this symbol.

 **WARNING:** Serious bodily injury or death may result from insufficient attention to or incorrect compliance with warning messages using this symbol.

 **CAUTION:** Bodily injury or damage to property may result from insufficient attention to or incorrect compliance with warning messages using this symbol.

Symbols

The triangle (\triangle) symbol indicates a warning including danger and caution. The specific point of attention is shown inside the symbol.



General warning.



Warning of risk of electric shock.



Warning of high temperature.

 indicates a prohibited action. The specific prohibition is shown inside the symbol.



General prohibited action.



Disassembly prohibited.

 indicates that action is required. The specific action required is shown inside the symbol.



General action required.





Remove the power plug from the wall outlet.











Always ground the copier.

1. Installation Precautions

WARNING











- Do not use a power supply with a voltage other than that specified. Avoid multiple connections to one outlet: they may cause fire or electric shock. When using an extension cable, always check that it is adequate for the rated current. 
- Connect the ground wire to a suitable grounding point. Not grounding the copier may cause fire or electric shock. Connecting the earth wire to an object not approved for the purpose may cause explosion or electric shock. Never connect the ground cable to any of the following: gas pipes, lightning rods, ground cables for telephone lines and water pipes or faucets not approved by the proper authorities. 

CAUTION:





- Do not place the copier on an infirm or angled surface: the copier may tip over, causing injury. 
- Do not install the copier in a humid or dusty place. This may cause fire or electric shock. 
- Do not install the copier near a radiator, heater, other heat source or near flammable material. This may cause fire. 
- Allow sufficient space around the copier to allow the ventilation grills to keep the machine as cool as possible. Insufficient ventilation may cause heat buildup and poor copying performance. 
- Always handle the machine by the correct locations when moving it. 
- Always use anti-toppling and locking devices on copiers so equipped. Failure to do this may cause the copier to move unexpectedly or topple, leading to injury. 
- Avoid inhaling toner or developer excessively. Protect the eyes. If toner or developer is accidentally ingested, drink a lot of water to dilute it in the stomach and obtain medical attention immediately. If it gets into the eyes, rinse immediately with copious amounts of water and obtain medical attention. 
- Advice customers that they must always follow the safety warnings and precautions in the copier's instruction handbook. 











2. Precautions for Maintenance

WARNING

- Always remove the power plug from the wall outlet before starting machine disassembly. 
- Always follow the procedures for maintenance described in the service manual and other related brochures. 
- Under no circumstances attempt to bypass or disable safety features including safety mechanisms and protective circuits. 
- Always use parts having the correct specifications. 
- Always use the thermostat or thermal fuse specified in the service manual or other related brochure when replacing them. Using a piece of wire, for example, could lead to fire or other serious accident. 
- When the service manual or other serious brochure specifies a distance or gap for installation of a part, always use the correct scale and measure carefully. 
- Always check that the copier is correctly connected to an outlet with a ground connection. 
- Check that the power cable covering is free of damage. Check that the power plug is dust-free. If it is dirty, clean it to remove the risk of fire or electric shock. 
- Never attempt to disassemble the optical unit in machines using lasers. Leaking laser light may damage eyesight. 
- Handle the charger sections with care. They are charged to high potentials and may cause electric shock if handled improperly. 



CAUTION

- Wear safe clothing. If wearing loose clothing or accessories such as ties, make sure they are safely secured so they will not be caught in rotating sections. 
- Use utmost caution when working on a powered machine. Keep away from chains and belts. 
- Handle the fixing section with care to avoid burns as it can be extremely hot. 
- Check that the fixing unit thermistor, heat and press rollers are clean. Dirt on them can cause abnormally high temperatures. 

- Do not remove the ozone filter, if any, from the copier except for routine replacement. 
- Do not pull on the AC power cord or connector wires on high-voltage components when removing them; always hold the plug itself. 
- Do not route the power cable where it may be stood on or trapped. If necessary, protect it with a cable cover or other appropriate item. 
- Treat the ends of the wire carefully when installing a new charger wire to avoid electric leaks. 
- Remove toner completely from electronic components. 
- Run wire harnesses carefully so that wires will not be trapped or damaged. 
- After maintenance, always check that all the parts, screws, connectors and wires that were removed, have been refitted correctly. Special attention should be paid to any forgotten connector, trapped wire and missing screws. 
- Check that all the caution labels that should be present on the machine according to the instruction handbook are clean and not peeling. Replace with new ones if necessary. 
- Handle greases and solvents with care by following the instructions below: 
 - Use only a small amount of solvent at a time, being careful not to spill. Wipe spills off completely.
 - Ventilate the room well while using grease or solvents.
 - Allow applied solvents to evaporate completely before refitting the covers or turning the power switch on.
 - Always wash hands afterwards.
- Never dispose of toner or toner bottles in fire. Toner may cause sparks when exposed directly to fire in a furnace, etc. 
- Should smoke be seen coming from the copier, remove the power plug from the wall outlet immediately. 

3. Miscellaneous

WARNING

- Never attempt to heat the drum or expose it to any organic solvents such as alcohol, other than the specified refiner; it may generate toxic gas. 
- Keep the machine away from flammable liquids, gases, and aerosols. A fire or an electric shock might occur. 

This page is intentionally left blank.

CONTENTS

1-1 Specifications

1-1-1 Specifications	1-1-1
1-1-2 Parts names	1-1-6
(1) Overall	1-1-6
(2) Operation panel	1-1-7
(3) Option	1-1-8
1-1-3 Machine cross section	1-1-9

1-2 Installation

1-2-1 Installation environment	1-2-1
1-2-2 Unpacking	1-2-2
(1) Unpacking	1-2-2
(2) Removing the tapes	1-2-3
1-2-3 Installing the expansion memory (option)	1-2-6

1-3 Maintenance Mode

1-3-1 Maintenance mode	1-3-1
(1) Executing a maintenance item	1-3-1
(2) Maintenance modes item list	1-3-2
(3) Contents of the maintenance mode items	1-3-5
1-3-2 Service mode	1-3-54
(1) Executing a service mode	1-3-54
(2) Description of service mode	1-3-55

1-4 Troubleshooting

1-4-1 Paper misfeed detection	1-4-1
(1) Paper misfeed indication	1-4-1
(2) Paper misfeed detection condition	1-4-2
1-4-2 Self-diagnostic function	1-4-3
(1) Self-diagnostic function	1-4-3
(2) Self diagnostic codes	1-4-4
1-4-3 Image formation problems	1-4-13
(1) Completely blank printout	1-4-14
(2) All-black printout	1-4-15
(3) Dropouts	1-4-15
(4) Black dots	1-4-16
(5) Black horizontal streaks	1-4-16
(6) Black vertical streaks	1-4-16
(7) Unsharpness	1-4-17
(8) Gray background	1-4-17
(9) Dirt on the top edge or back of the paper	1-4-17
(10) Undulated printing at the right edge (scanning start position)	1-4-18
1-4-4 Electric problems	1-4-19
1-4-5 Mechanical problems	1-4-23
1-4-6 Send error code	1-4-24
(1) Scan to SMB error codes	1-4-24
(2) Scan to FTP error codes	1-4-25
(3) Scan to E-mail error codes	1-4-27

1-4-7 Error codes	1-4-29
(1) Error code	1-4-29
(2) Table of general classification	1-4-30
(2-1) U004XX error code table: Interrupted phase B	1-4-33
(2-2) U006XX error code table: Problems with the unit	1-4-34
(2-3) U008XX error code table: Page transmission error.....	1-4-34
(2-4) U009XX error code table: Page reception error	1-4-34
(2-5) U010XX error code table: G3 transmission	1-4-35
(2-6) U011XX error code table: G3 reception	1-4-37
(2-7) U017XX error code table: V.34 transmission	1-4-38
(2-8) U018XX error code table: V.34 reception.....	1-4-39
(2-9) U023XX error code table: Relay command abnormal reception	1-4-39
(2-10) U044XX error code table: Encrypted transmission	1-4-39

1-5 Assembly and Disassembly

1-5-1 Precautions for assembly and disassembly.....	1-5-1
(1) Precautions.....	1-5-1
(2) Drum unit	1-5-1
(3) Toner	1-5-1
(4) How to tell a genuine Kyocera Mita toner container	1-5-2
1-5-2 Outer covers	1-5-3
(1) Detaching and refitting the left cover and right cover	1-5-3
1-5-3 Paper feed section.....	1-5-6
(1) Detaching and refitting the paper feed assembly (paper feed roller and pickup roller)	1-5-6
(2) Detaching and refitting the retard roller assembly	1-5-8
(3) Detaching and refitting the MP paper feed roller	1-5-10
(4) Note on removing and Installing the upper registration roller and lower registration roller	1-5-12
1-5-4 Optical section	1-5-13
(1) Detaching and refitting the DP.....	1-5-13
(2) Detaching and refitting the scanner unit	1-5-14
(3) Detaching and refitting the laser scanner unit (LSU).....	1-5-17
(4) Replacing the image scanner unit (ISU).....	1-5-21
1-5-5 Developer section	1-5-27
(1) Detaching and refitting the developer unit.....	1-5-27
1-5-6 Drum section	1-5-28
(1) Detaching and refitting the drum unit.....	1-5-28
(2) Detaching and refitting the main charger unit.....	1-5-29
1-5-7 Transfer/separation section	1-5-30
(1) Detaching and refitting the transfer roller	1-5-30
1-5-8 Fuser section	1-5-32
(1) Detaching and refitting the fuser unit.....	1-5-32
(2) Switching the fuser pressure	1-5-36
1-5-9 PWBs.....	1-5-37
(1) Detaching and refitting the control PWB.....	1-5-37
(2) Detaching and refitting the power source PWB.....	1-5-40
(3) Detaching and refitting the high voltage PWB	1-5-43
(4) Detaching and refitting the scanner PWB.....	1-5-47
(5) Detaching and refitting the FAX control PWB.....	1-5-48

1-5-10 Others	1-5-49
(1) Detaching and refitting the main motor	1-5-49
(2) Direction of installing the left cooling fan motor, right cooling fan motor and power source fan motor	1-5-50
1-5-11 Document processor	1-5-51
(1) Detaching and refitting the DP rear cover and DP front cover	1-5-51
(2) Detaching and refitting the DP drive PWB.....	1-5-52
(3) Detaching and refitting the feed pulley and forwarding pulley	1-5-53
(4) Detaching and refitting the separation pad assembly.....	1-5-56
1-6 Requirements on PWB Replacement	
1-6-1 Upgrading the firmware	1-6-1
1-6-2 Remarks on control PWB replacement.....	1-6-2
2-1 Mechanical Construction	
2-1-1 Paper feed/conveying section	2-1-1
(1) Cassette paper feed section	2-1-1
(2) MP tray paper feed section.....	2-1-2
(3) Paper conveying section	2-1-3
2-1-2 Drum section	2-1-4
(1) Drum section	2-1-4
(2) Main charger unit.....	2-1-5
2-1-3 Optical section	2-1-6
(1) Scanner unit	2-1-6
(2) Image scanner unit (ISU).....	2-1-7
(3) Laser scanner unit	2-1-9
2-1-4 Developing section	2-1-11
2-1-5 Transfer/separation section	2-1-13
2-1-6 Cleaning section	2-1-14
2-1-7 Fuser section	2-1-16
2-1-8 Paper exit section	2-1-18
2-1-9 Duplex/conveying section	2-1-20
2-1-10 Document processor	2-1-21
(1) Original feed section.....	2-1-21
(2) Original conveying section.....	2-1-22
(3) Original switchback/eject sections.....	2-1-23
2-2 Electrical Parts Layout	
2-2-1 Electrical parts layout	2-2-1
(1) PWBs.....	2-2-1
(2) Switches and sensors.....	2-2-3
(3) Other electrical components.....	2-2-4
(4) Document processor	2-2-5
2-3 Operation of the PWBs	
2-3-1 Power source PWB	2-3-1
2-3-2 Control PWB	2-3-4
2-3-3 Scanner PWB	2-3-11
2-3-4 DP drive PWB.....	2-3-14

2-4 Appendixes

2-4-1 Appendixes	2-4-1
(1) Wiring diagram	2-4-1
(2) Repetitive defects gauge	2-4-3
(3) Maintenance parts list.....	2-4-4
(4) Firmware Environment Commands	2-4-5

INSTALLATION GUIDE

PAPER FEEDER

1-1-1 Specifications

Machine

Item	Specifications				
	3 in 1 model (without FAX)		4 in 1 model (with FAX)		
	30ppm	35ppm	30ppm	35ppm	
Type	Desktop				
Printing method	Electrophotography by semiconductor laser, single drum system				
Originals	Sheet, Book, 3-dimensional objects (maximum original size: Folio/Legal)				
Original feed system	Fixed				
Paper weight	Cassette	60 to 120 g/m ² (Duplex: 60 to 105 g/m ²)			
	MP tray	60 to 220 g/m ²			
Paper type	Cassette	Plain, Preprinted, Bond, Recycled, Rough, Letterhead, Color, Prepunched, High quality, Custom 1-8			
	MP tray	Plain, Transparency, Preprinted, Labels, Bond, Recycled, Vellum, Rough, Letterhead, Color, Prepunched, Envelope, Cardstock, Thick, High quality, Custom 1-8			
Paper size	Cassette	A4, A5, B5, Letter, Legal, Statement, Oficio II, Folio, 16K, 216×340, Custom			
	MP tray	A4, A5, A6, B5, ISO B5, Letter, Legal, Statement, Executive, Oficio II, Folio, 16K, 216×340, Custom			
Zoom level	Manual mode : 25 to 400%, 1% increments Auto mode : 400%, 200%, 141%, 129%, 115%, 90%, 86%, 78%, 70%, 64%, 50%, 25%				
Copying speed					
When using the DP (Cassette)	A4R	20 sheets/min			
	LetterR	21 sheets/min			
	Legal	17 sheets/min			
	B5R	22 sheets/min			
	A5R	17 sheets/min			
When the DP is not used (Cassette)	A4R	30 sheets/min	35 sheets/min	30 sheets/min	35 sheets/min
	LetterR	32 sheets/min	37 sheets/min	32 sheets/min	37 sheets/min
	Legal	26 sheets/min	30 sheets/min	26 sheets/min	30 sheets/min
	B5R	24 sheets/min	24 sheets/min	24 sheets/min	24 sheets/min
	A5R	17 sheets/min	17 sheets/min	17 sheets/min	17 sheets/min
	A6R	17 sheets/min	17 sheets/min	17 sheets/min	17 sheets/min
First copy time (A4, feed from cassette)	When using the DP : 7.9 s or less When the DP is not used: 6.9 s or less				
Warm-up time (22 °C/71.6 °F, 60% RH)	Power on : 20 s or less				
Paper capacity	Cassette	250 sheets (80g/m ²)			
	MP tray	50 sheets (80 g/m ² , plain paper, A4/Letter or less)			

Item	Specifications			
	3 in 1 model (without FAX)		4 in 1 model (with FAX)	
	30ppm	35ppm	30ppm	35ppm
Output tray capacity	150 sheets (80g/m ²)			
Continuous copying	1 to 999 sheets			
Light source	Exposure lamp (LED)			
Scanning system	Flat bed scanning by CCD image sensor			
Photoconductor	OPC drum (diameter 30 mm)			
Image write system	Semiconductor laser			
Charging system	Scorotron (positive charging)			
Developing system	Mono component dry developing method Toner replenishing: Automatic from the toner container			
Transfer system	Transfer roller (negative charging)			
Separation system	Small diameter separation, discharger electrode			
Cleaning system	Drum: Counter blade			
Charge erasing system	Exposure by cleaning lamp (LED)			
Fusing system	Heat and pressure fusing with the heat roller and the press roller Heat source: halogen heater Abnormally high temperature protection devices: thermostat			
CPU	PowerPC440 (667MHz)			
Main memory	Standard	256 MB		
	Maximum	768 MB		
Interface	Standard	USB interface connector: 1 (USB Hi-speed) USB host: 1 Network interface: 1 (10BASE-T/100BASE-TX)		
	Option	KUIO/W slot: 1 (It uses it by fax in 4in1 model.)		
Resolution	Reading	600 × 600 dpi		
	Writing	600 × 600 dpi	1200 × 1200 dpi	600 × 600 dpi 1200 × 1200 dpi
Operating environment	Temperature	10 to 32.5 °C/50 to 90.5 °F		
	Humidity	15 to 80% RH		
	Altitude	2,500 m/8,202 ft or less		
	Brightness	1,500 lux or less		
Dimensions (W × D × H)	494 × 410 × 366 mm 19 7/16 × 16 1/8 × 14 7/16" (When using the original cover)		494 × 430 × 448 mm 19 7/16 × 16 15/16 × 17 1/4" (When using the DP)	
Weight (with toner container)	15 kg / 33.1 lb (with original cover) 18 kg / 39.7 lb (with DP)			
Space required (W × D) (using MP tray)	494 × 613 mm 19 7/16 × 24 1/8"		494 × 633 mm 19 7/16 × 24 15/16"	

Item	Specifications			
	3 in 1 model (without FAX)		4 in 1 model (with FAX)	
	30ppm	35ppm	30ppm	35ppm
Power source	120 V AC, 60 Hz, more than 10.0 A 220 - 240 V AC, 50/60 Hz, more than 6.0 A			
Options	Paper feeder × 2, Expanded memory, CF card (for printer), Network interface kit			

Printer

Item	Specifications		
	30ppm	35ppm	
Printing speed			
Simplex (Cassette)	A4R	30 sheets/min	35 sheets/min
	LetterR	32 sheets/min	37 sheets/min
	Legal	26 sheets/min	30 sheets/min
	B5R	24 sheets/min	24 sheets/min
	A5R	17 sheets/min	17 sheets/min
	A6R	17 sheets/min	17 sheets/min
Duplex (Cassette)	A4R	17 sheets/min	19 sheets/min
	LetterR	18 sheets/min	20 sheets/min
	Legal	16 sheets/min	18 sheets/min
First print time (A4, feed from cassette)	6.0 s or less	7.0 s or less	
Resolution	Fast 1200 600 dpi 300 dpi	Fine 1200 Fast 1200 600 dpi 300 dpi	
Operating system	Windows 2000, Windows XP, Windows XP Professional, Windows Server 2003, Windows Server 2003 x64 Edition, Windows Vista x86 Edition, Windows Vista x64 Edition, Windows 7 x86 Edition, Windows 7 x64 Edition, Windows Server 2008, Windows Server 2008 x64 Edition Apple Macintosh OS 9.x, Apple Macintosh OS X		
Interface	USB interface connector: 1 (USB Hi-speed) USB host: 1 Network interface: 1 (10BASE-T/100BASE-TX)		
Page description language	PRESCRIBE		

Scanner

Item		Specifications
Operating system		Windows 2000 (Service Pack 4), Windows XP, Windows Vista, Windows 7, Windows Server 2003, Windows Server 2008
Resolution		600 dpi, 400 dpi, 300 dpi, 200 dpi, 200 × 400 dpi, 200 × 100 dpi
File format		JPEG, TIFF, PDF, XPS
Scanning speed	Simplex	B/W : 35 images/min Color: 14 images/min (A4 landscape, 300 dpi, Image quality: Text/Photo original)
	Duplex	B/W : 18 images/min Color: 8 images/min (A4 landscape, 300 dpi, Image quality: Text/Photo original)
Interface		Ethernet (10 BASE-T/100 BASE-TX), USB2.0 (Hi-Speed USB)
Network protocol		TCP/IP
Transmission system		PC transmission SMB: Scan to PC E-mail SMTP: Scan to E-mail FTP transmission FTP, FTP over SSL: Scan to FTP USB transmission USB: Scan to USB TWAIN scan *1 WIA scan *2

*1 Available operating system: Windows XP, Windows Server 2003, Windows Vista, Windows Server 2008, Windows 7

*2 Available operating system: Windows Vista, Windows Server 2008, Windows 7

Document processor (Standard model only)

Item	Specifications
Original feed method	Automatic feed
Supported original types	Sheet originals
Original sizes	Maximum: A4/Legal Minimum : A5/Statement
Original weights	Simplex: 50 to 120 g/m ² Duplex : 50 to 110 g/m ²
Loading capacity	50 sheets (50 to 80 g/m ²) or less
Dimensions (W × D × H)	490 × 339 × 104 mm 19 5/16 × 13 3/8 × 4 1/8"
Weight	3 kg/ 6.6 lb or less

FAX (4 in 1 model (with FAX) only)

Item	Specifications
Compatibility	Super G3
Communication line	Subscriber telephone line
Transmission time	3 s or less (33600 bps, JBIG, ITU-T A4 #1 chart)
Transmission speed	33600/31200/28800/26400/24000/21600/19200/16800/14400/12000/9600/7200/4800/2400 bps
Coding scheme	JBIG/MMR/MR/MH
Error correction	ECM
Original size	A4, B5(JIS), A5, Legal, Letter, Statement, Oficio II, 216x340
Automatic document feed	Max. 50 sheets
Scanner resolution	Horizontal × Vertical 200 × 100 dpi Normal (8 dot/mm × 3.85 line/mm) 200 × 200 dpi Fine (8 dot/mm × 7.7 line/mm) 200 × 400 dpi Super fine (8 dot/mm × 15.4 line/mm) 400 × 400 dpi Ultra fine (16 dot/mm × 15.4 line/mm)
Printing resolution	600 × 600 dpi
Gradations	256 shades
One-Touch key	22 keys
Multi-Station transmission	Max. 100 destinations
Substitute memory reception	256 sheets or more (when using ITU-T A4 #1 chart)
Image memory capacity	3.5 MB (standard) (for incoming faxed originals)
Report output	Sent result report, FAX RX result report, Activity report, Status page

NOTE: These specifications are subject to change without notice.

1-1-2 Parts names

(1) Overall

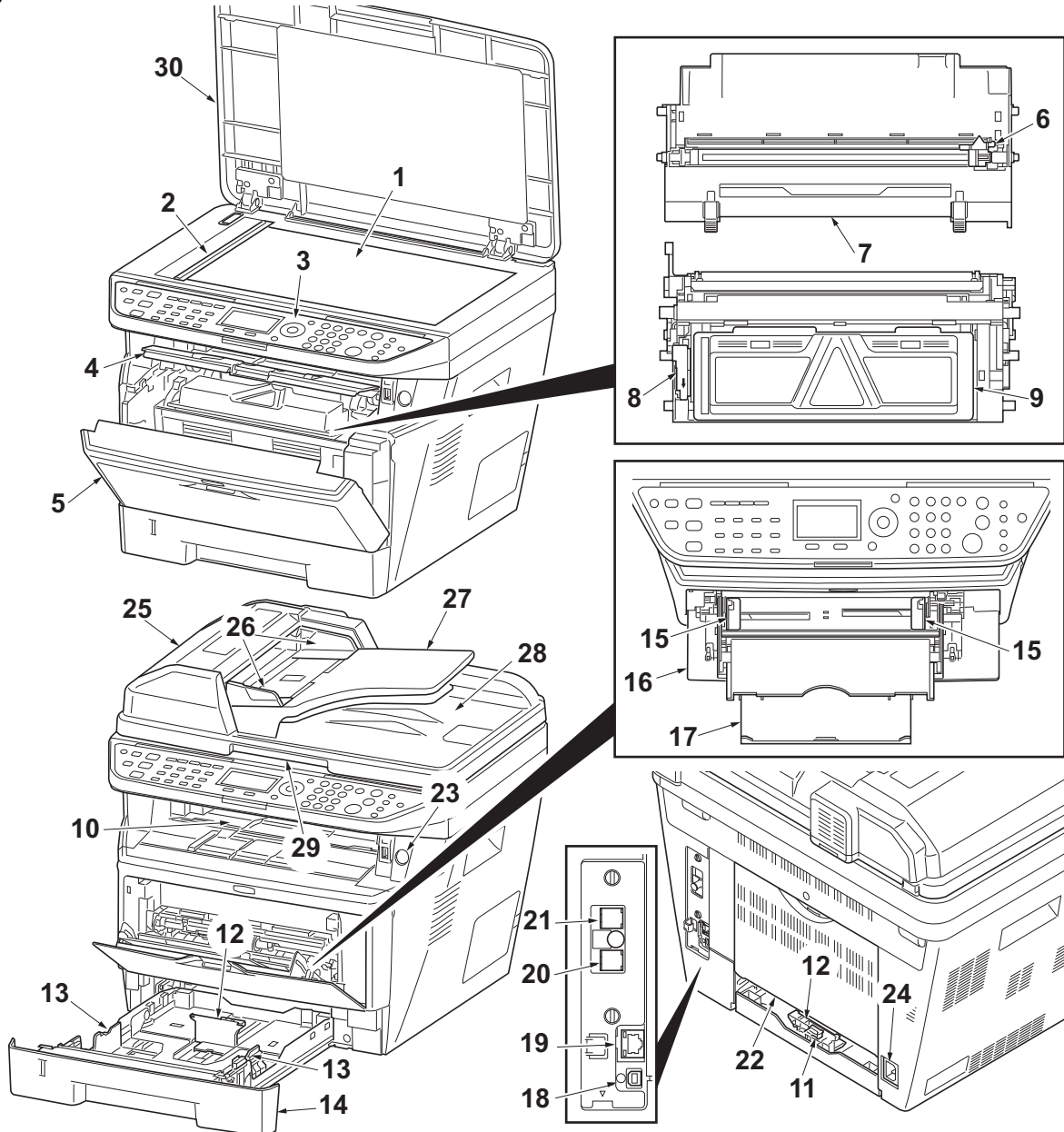

Figure 1-1-1

- | | | |
|----------------------------------|----------------------------------|------------------------------|
| 1. Platen (contact glass) | 12. Paper stopper | 23. Power switch |
| 2. Original size Indicator plate | 13. Paper width guides | 24. Power cord connector |
| 3. Operation panel | 14. Cassette | 25. Top cover |
| 4. Top cover | 15. Paper width guides (MP tray) | 26. Original width guides *2 |
| 5. Front cover | 16. MP (Multi-Purpose) tray | 27. Original table *2 |
| 6. Main charger cleaner | 17. MP tray extension | 28. Original eject table *2 |
| 7. Drum unit | 18. USB Interface connector | 29. Opening handle *2 |
| 8. Lock lever | 19. Network Interface connector | 30. USB host connector |
| 9. Toner container | 20. Tel connector (T1) *1 | 31. Original cover *3 |
| 10. Top tray | 21. Line connector (L1) *1 | |
| 11. Paper length guide | 22. Rear cover | |

*1: 4in1 model (with FAX) only

*2: Only model with Document Processor as standard / *3: Only model with original cover as standard

(2) Operation panel

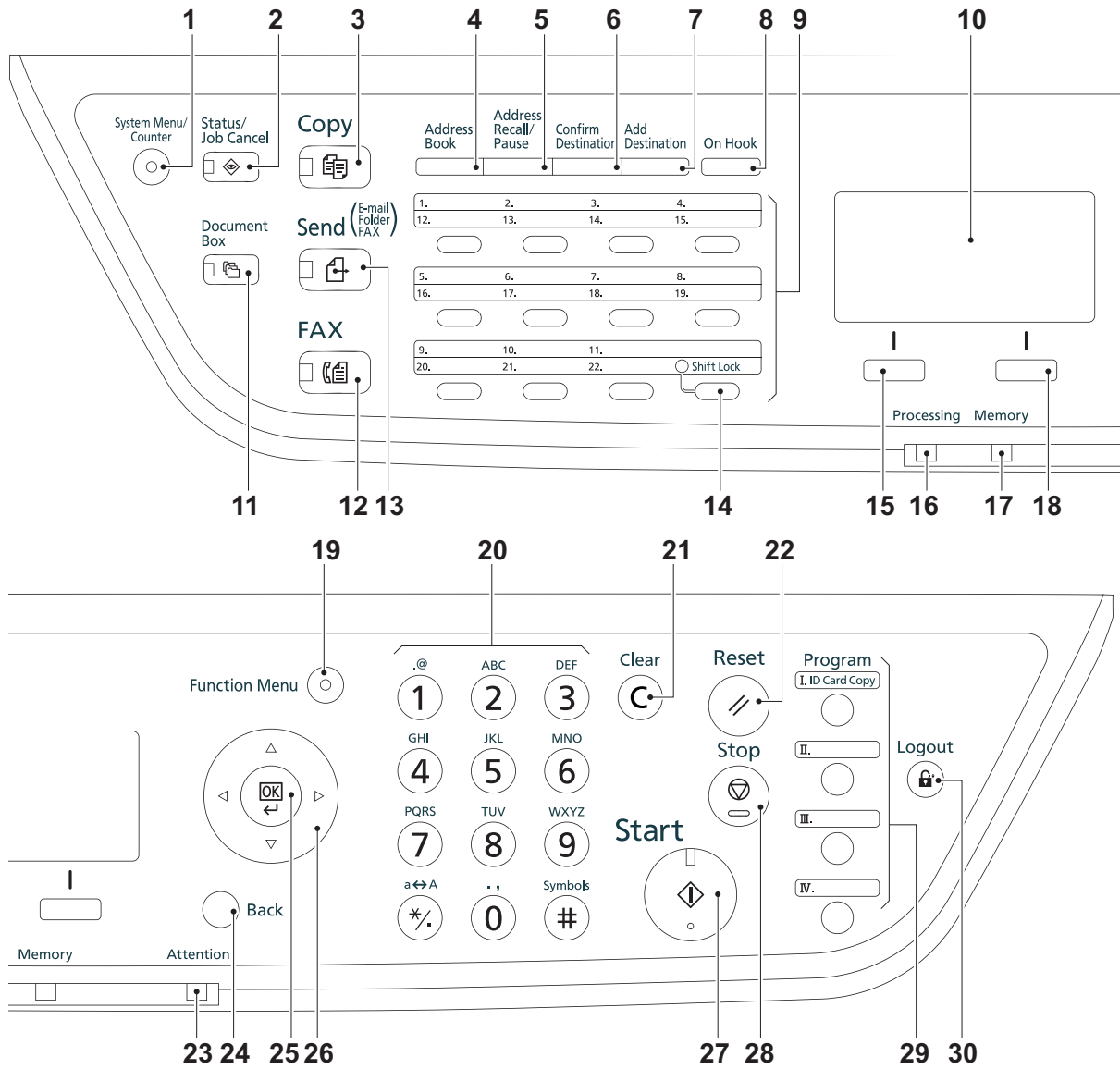
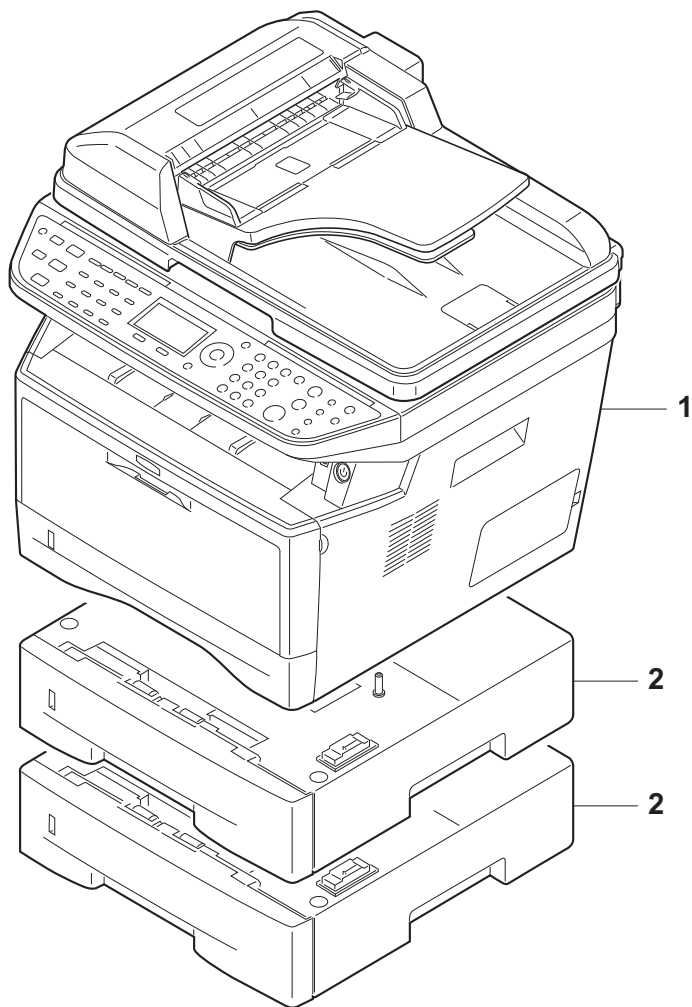

Figure 1-1-2

- | | | |
|----------------------------------|-----------------------------|-------------------------|
| 1. System menu/Counter key (LED) | 11. Document Box key (LED) | 22. Reset key |
| 2. Status/Job Cancel key (LED) | 12. FAX key (LED) * | 23. Attention indicator |
| 3. Copy key (LED) | 13. Send key (LED) | 24. Back key |
| 4. Address Book key | 14. Shift Lock key (LED) | 25. OK key |
| 5. Address Recall/Pause key * | 15. Left Select key | 26. Cursor keys |
| 6. Confirm Destination key | 16. Processing indicator | 27. Start key (LED) |
| 7. Add Destination key | 17. Memory indicator | 28. Stop key |
| 8. On Hook key * | 18. Right Select key | 29. Program keys |
| 9. One-touch keys | 19. Function Menu key (LED) | 30. Logout key (LED) |
| 10. Message display | 20. Numeric keys | |
| | 21. Clear key | |

*: 4in1 model (with FAX) only

(3) Option



System Kit



Exption memory: for copy and printer
General-purpose 144pin DIMM (1 slot)

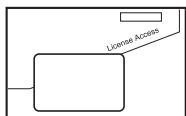

Card Authentication Kit(B)



Network interface Kit
IB-23
* 3in1 model only

Figure 1-1-3

- 1. Machine
- 2. Paper feeder

1-1-3 Machine cross section

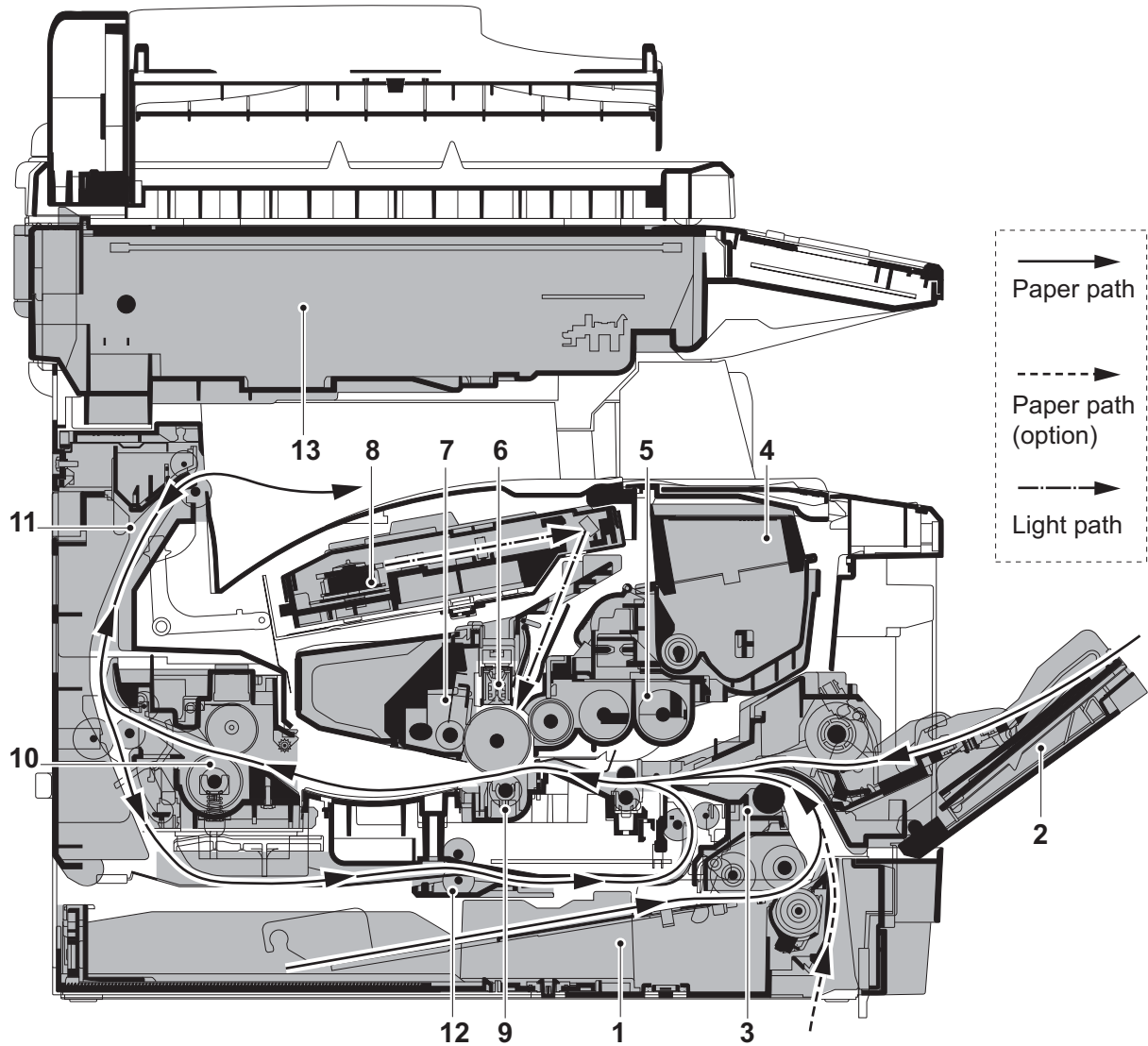

Figure 1-1-4

- | | |
|---------------------------------|--------------------------------|
| 1. Cassette | 8. Laser scanner unit (LSU) |
| 2. MP tray | 9. Transfer/separation section |
| 3. Paper feed/conveying section | 10. Fuser section |
| 4. Toner container | 11. Exit section |
| 5. Developer unit | 12. Duplex/conveying section |
| 6. Main charger unit | 13. Scanner section |
| 7. Drum unit | |

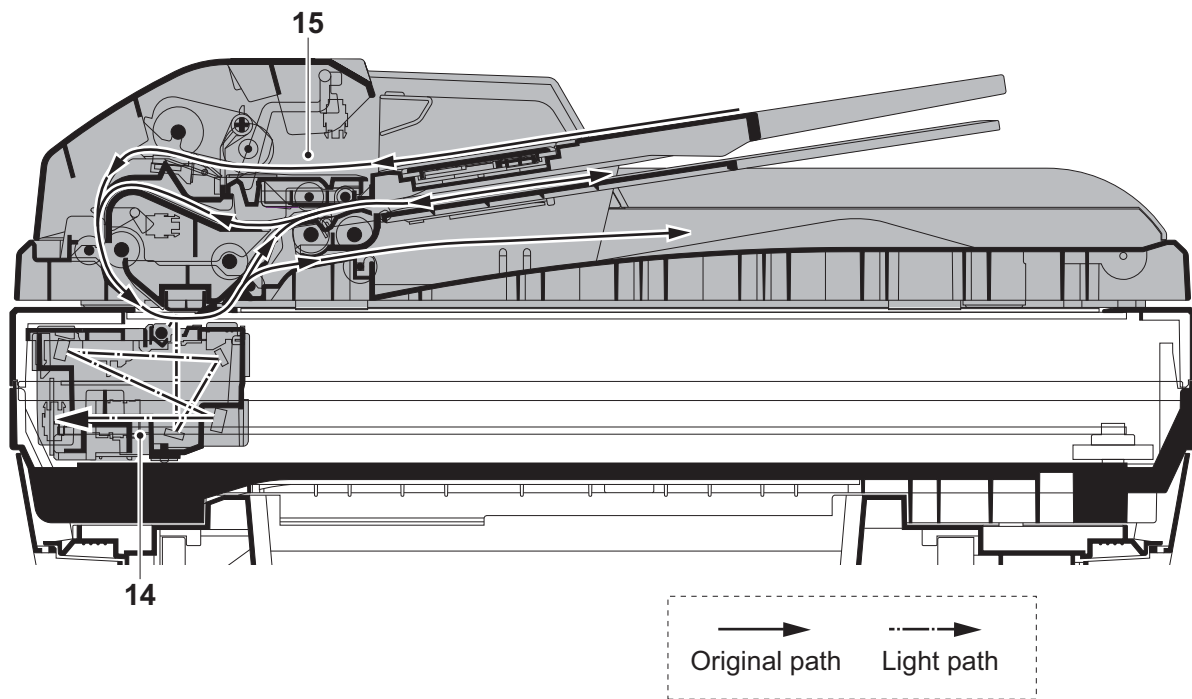

Figure 1-1-5

- 14. Image scanner unit (ISU)
- 15. Document processor (DP) *

* : Only model with Document Processor as standard

This page is intentionally left blank.

1-2-1 Installation environment

1. Temperature: 10 to 32.5°C/50 to 90.5°F
2. Humidity: 15 to 80%RH
3. Power supply: 120 V AC, 7.8 A
220 - 240 V AC, 4.0 A
4. Power source frequency: 50 Hz ±0.3%/60 Hz ±0.3%
5. Installation location

Avoid direct sunlight or bright lighting. Ensure that the photoconductor will not be exposed to direct sunlight or other strong light when removing paper jams.

Avoid locations subject to high temperature and high humidity or low temperature and low humidity; an abrupt change in the environmental temperature; and cool or hot, direct air.

Avoid places subject to dust and vibrations.

Choose a surface capable of supporting the weight of the machine.

Place the machine on a level surface (maximum allowance inclination: 1°).

Avoid air-borne substances that may adversely affect the machine or degrade the photoconductor, such as mercury, acidic or alkaline vapors, inorganic gasses, NOx, SOx gases and chlorine-based organic solvents.

Select a well-ventilated location.

6. Allow sufficient access for proper operation and maintenance of the machine.

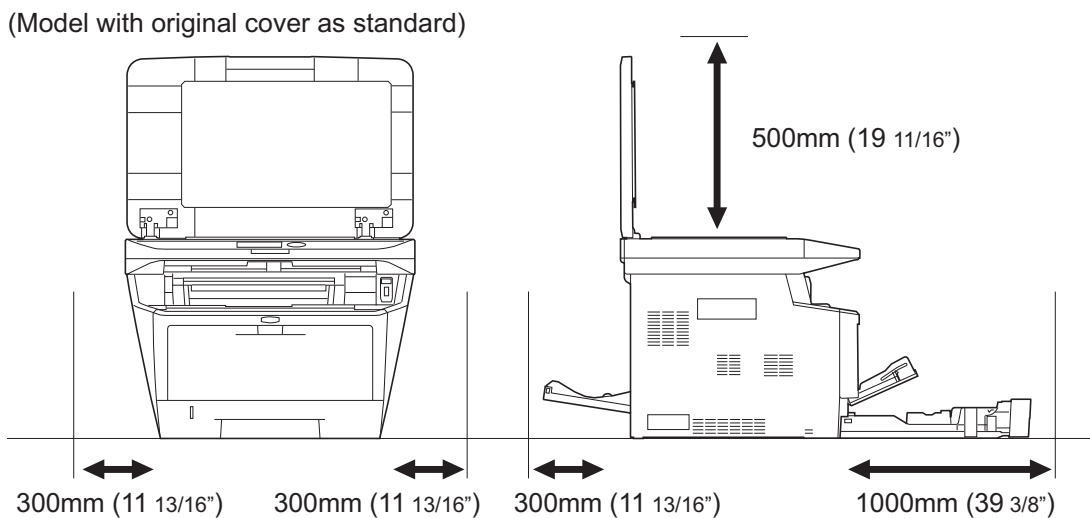
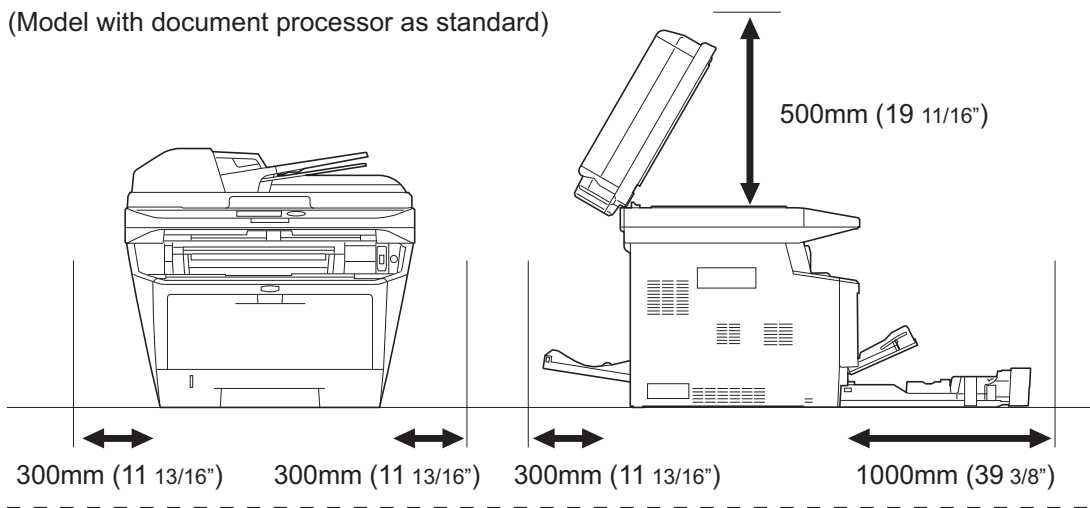

Figure 1-2-1

1-2-2 Unpacking

(1) Unpacking

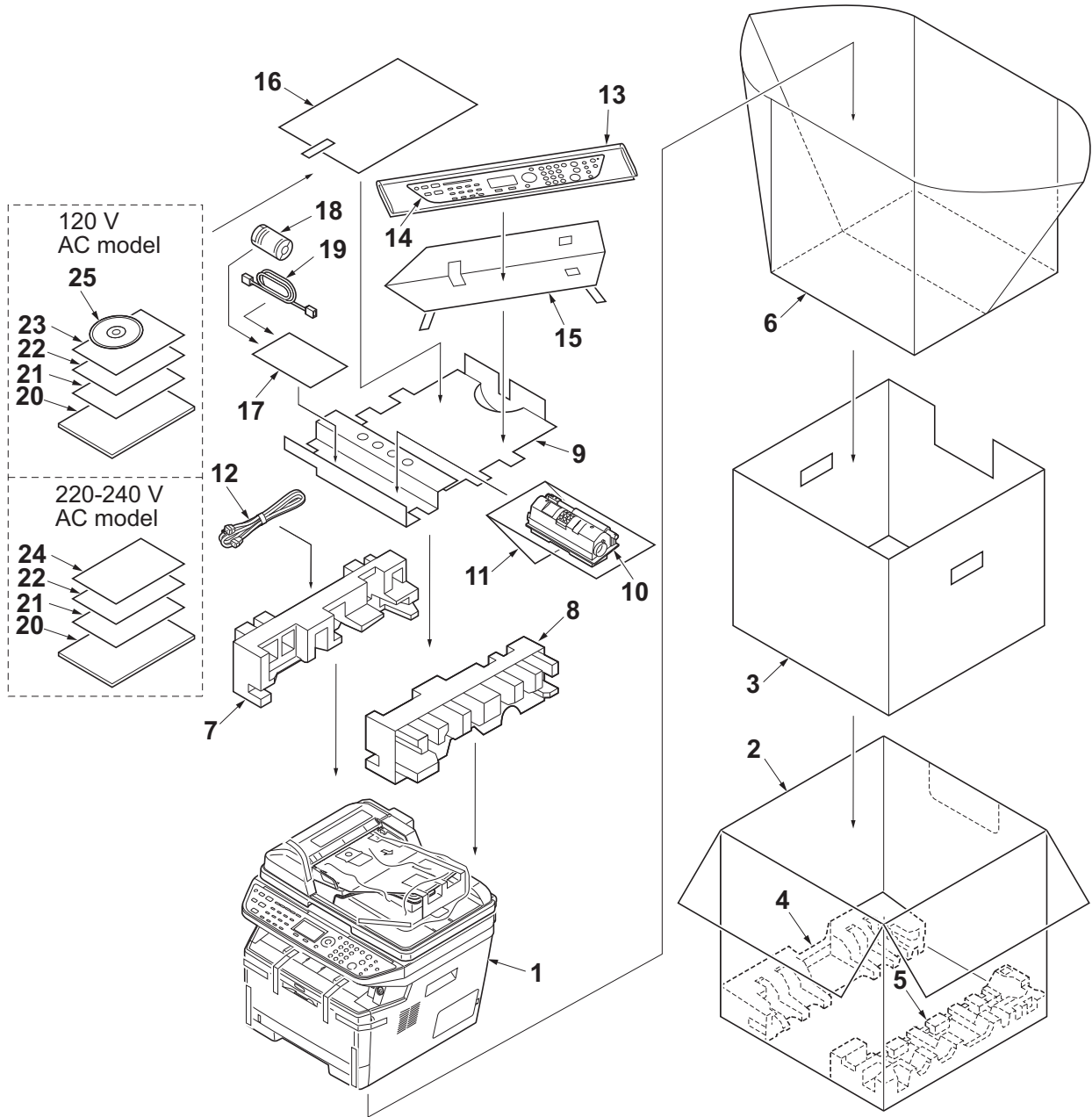

Figure 1-2-2

- | | | |
|---------------------|------------------------------|--------------------------------|
| 1. Machine | 11. Plastic bag | 21. Safety guide 1 |
| 2. Outer case | 12. Power cord | 22. Safety guide 2 |
| 3. Inner frame | 13. Plastic bag (250 ´ 600) | 23. Toner OSHA leaflet * |
| 4. Bottom pad L | 14. Operation labels | 24. EEA information leaflet ** |
| 5. Bottom pad R | 15. Operation label pad | 25. DVD-ROM* |
| 6. Machine cover | 16. Plastic bag (240 ´ 350) | |
| 7. Top pad L | 17. Plastic bag | |
| 8. Top pad R | 18. Ferrite core | |
| 9. Accessory spacer | 19. Modular cable * | |
| 10. Toner container | 20. Quick installation guide | |

* 120 V AC model only.

** 220-240 V AC model only.

(2) Removing the tapes

<Procedure>

1. Remove two tapes.
2. Open the sheet.

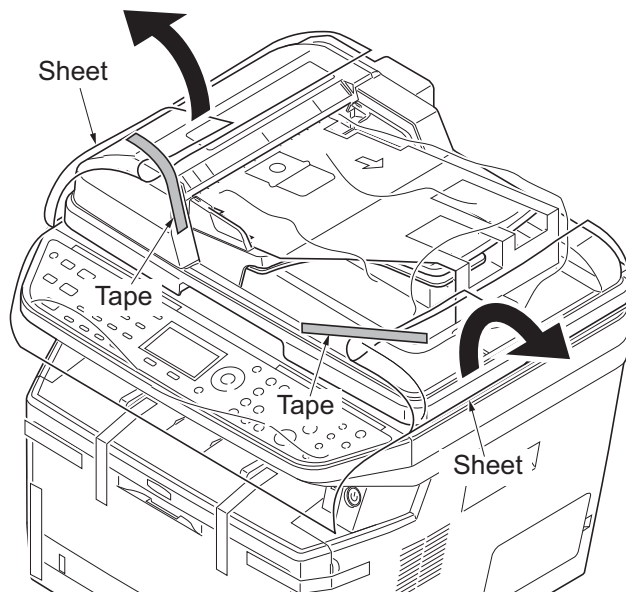

Figure 1-2-3

3. Remove two tapes A.
4. Open the top cover.
5. Remove the tape B and then remove the spacer.
6. Close the top cover.

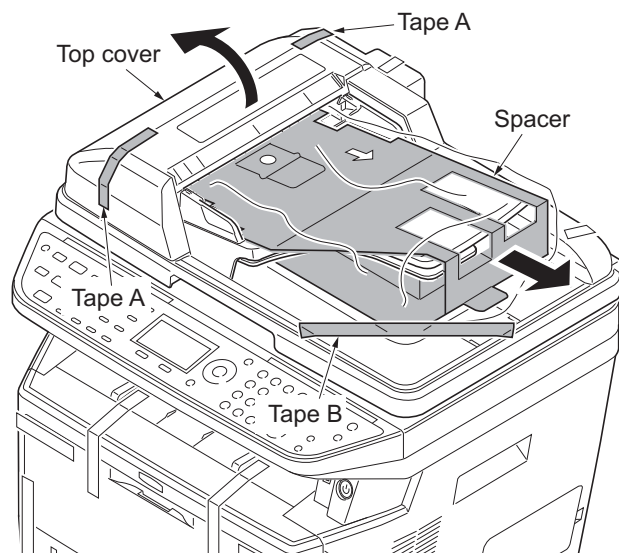

Figure 1-2-4

7. Remove two tapes.

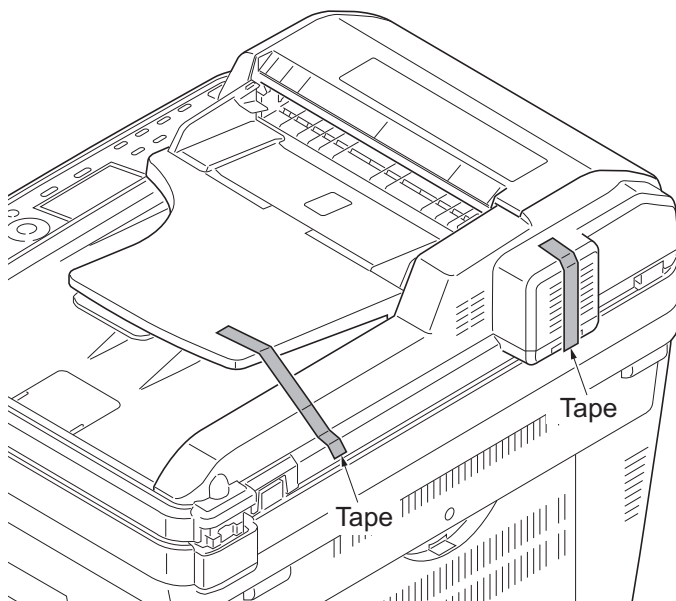

Figure 1-2-5

- 8. Open the DP.
- 9. Remove the sheet.
- 10. Remove the paper.

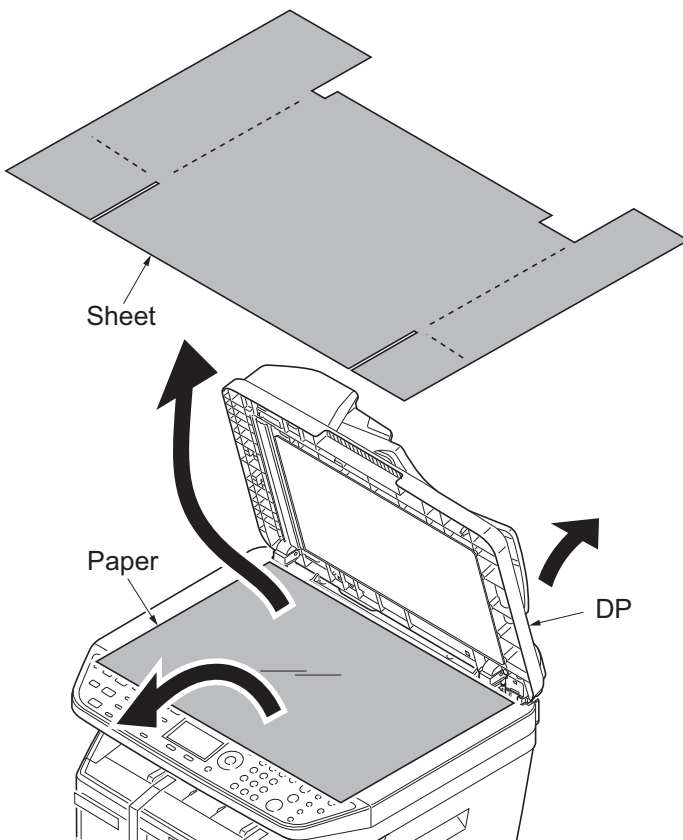

Figure 1-2-6

11. Remove the tape A.
12. Move the lock lever to the position of release.
 - * : When turning on power if the lock lever is not released, the error message is displayed.
13. Close the DP.
14. Remove eight tapes B.

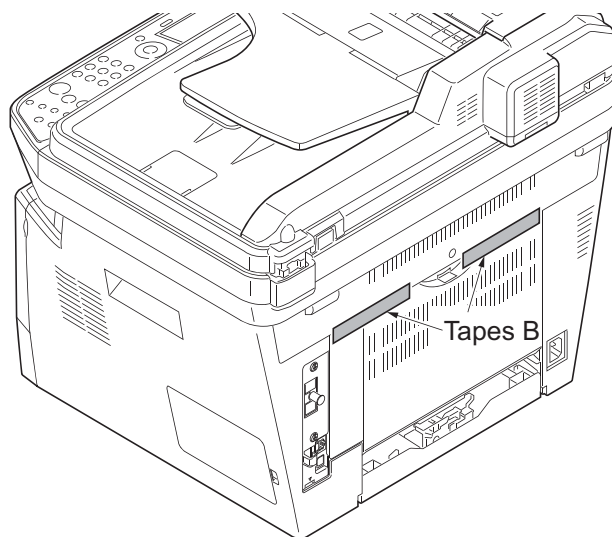
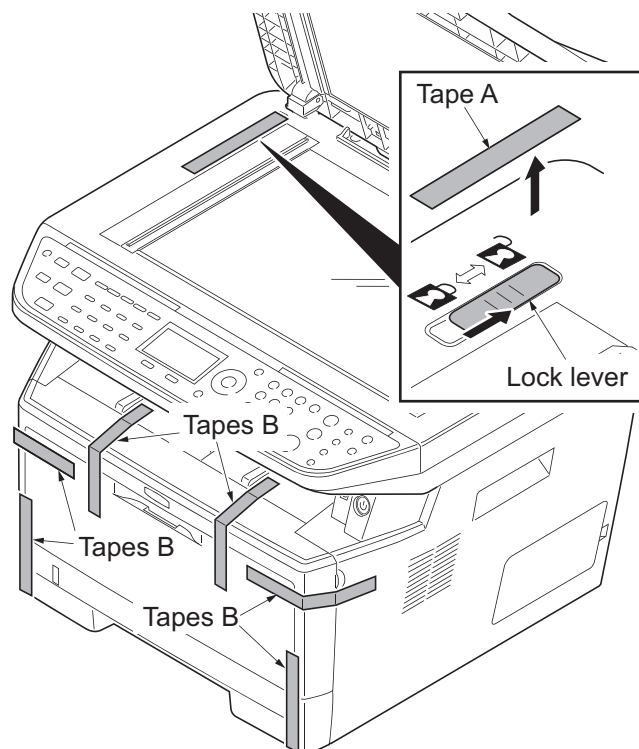

Figure 1-2-7

1-2-3 Installing the expansion memory (option)

<Procedure>

1. Turn off the power switch and pull out the power cable.
Caution: Do not insert or remove expansion memory while machine power is on.
Doing so may cause damage to the machine and the expansion memory.
2. Remove the right side cover.
3. Remove the screw.

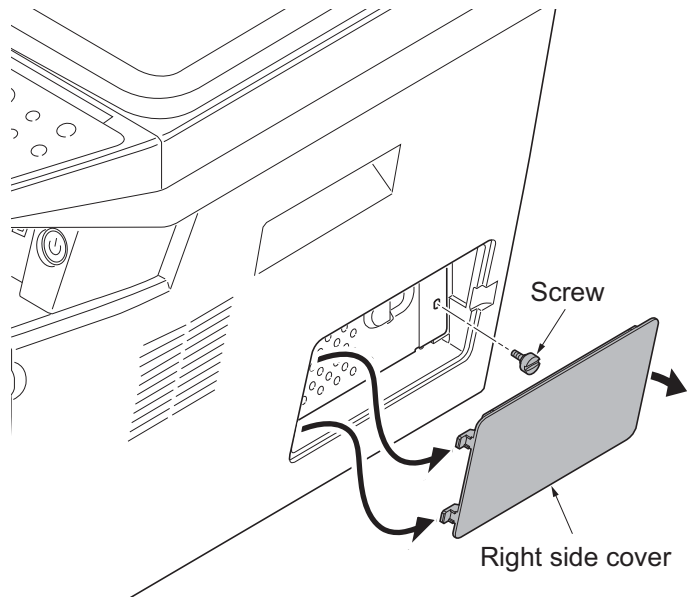

Figure 1-2-8

4. Open the memory slot cover.
5. Insert the expansion memory into the memory socket so that the notches on the memory align with the corresponding protrusions in the slot.
6. Close the memory slot cover.
7. Secure the screw.
8. Refit the right side cover.
9. Print a status page to check the memory expansion.

If memory expansion has been properly performed, information on the installed memory is printed with the total memory capacity has been increased. Standard memory capacity 256 MB.

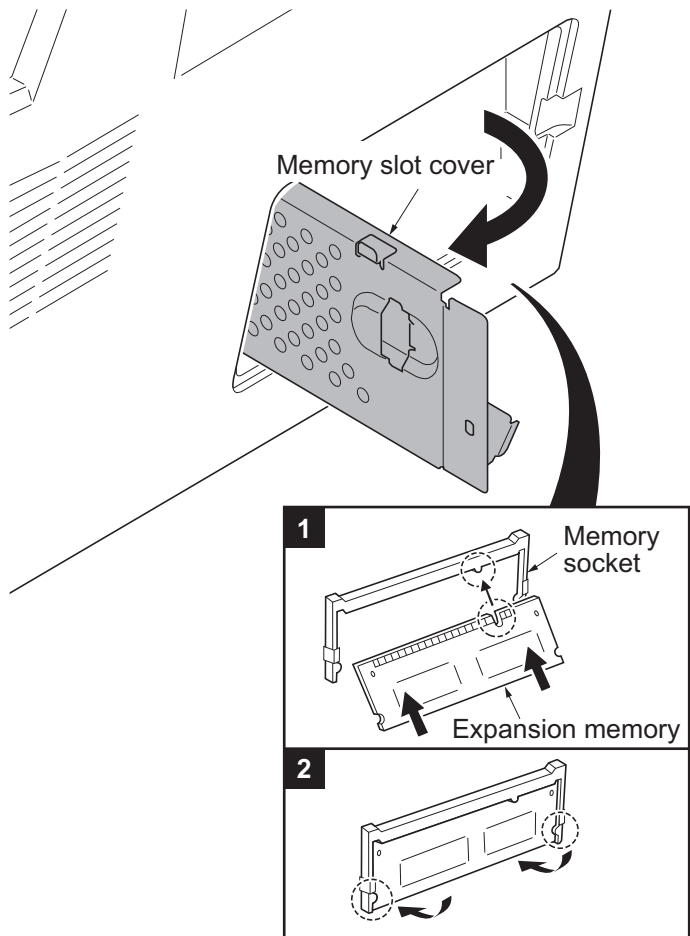
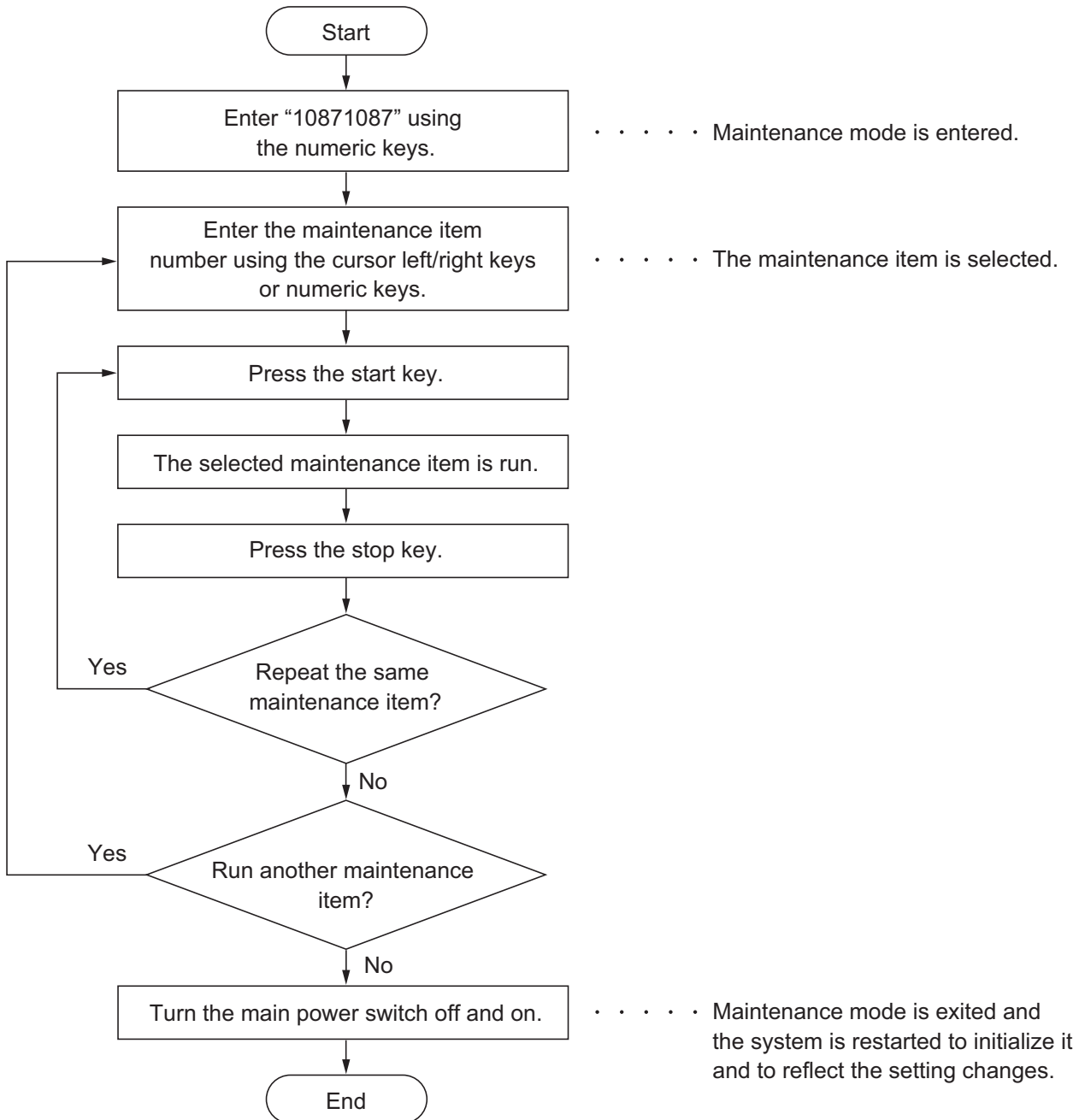

Figure 1-2-9

1-3-1 Maintenance mode

The machine is equipped with a maintenance function which can be used to maintain and service the machine.

(1) Executing a maintenance item



(2) Maintenance modes item list

Section	Item No.	Content of maintenance item	Initial setting
General	U000	Outputting an maintenance report	-
	U002	Setting the factory default data	-
	U004	Setting the machine number	-
Operation panel and support equipment	U203	Checking DP operation	-
	U222	Setting the IC card type	Other
Mode setting	U250	Setting the maintenance cycle	100000
	U251	Checking/clearing the maintenance count	-
	U252	Setting the destination	-
	U253	Switching between double and single counts	Double count
	U260	Selecting the timing for copy counting	EJECT
	U285	Setting service status page	ON
	U332	Setting the size conversion factor	1.0
	U345	Setting the value for maintenance due indication	0
Image processing	U411	Adjusting the scanner automatically	-
	U425	Setting the target	-
Fax	U600	Initializing all data	-
	U601	Initializing permanent data	-
	U603	Setting user data 1	DTMF
	U604	Setting user data 2	2 (120 V) 1 (220-240 V)
	U605	Clearing data	-
	U610	Setting system 1	3
		Setting the number of lines to be ignored when receiving a fax at 100% magnification	0
		Setting the number of lines to be ignored when receiving a fax (A4R/LetterR) in the auto reduction mode	0
	U611	Setting system 2	7
		Setting the number of adjustment lines for automatic reduction	22
Setting the number of adjustment lines for automatic reduction when letter size paper is set		26	
U612	Setting system 3	ON	
	Selecting if auto reduction in the auxiliary direction is to be performed Setting the automatic printing of the protocol list	OFF	

Section	Item No.	Content of maintenance item	Initial setting
Fax	U620	Setting the remote switching mode	ONE
	U625	Setting the transmission system 1 Setting the auto redialing interval Setting the number of times of auto redialing	3 (120 V) 2 (220-240 V) 2 (120 V) 3 (220-240 V)
	U630	Setting communication control 1 Setting the communication starting speed Setting the reception speed Setting the waiting period to prevent echo problems at the sender Setting the waiting period to prevent echo problems at the receiver	14400bps/V17 14400bps 300 75
	U631	Setting communication control 2 Setting ECM transmission Setting ECM reception Setting the frequency of the CED signal	ON ON 2100
	U632	Setting communication control 3 Setting the DIS signal to 4 bytes Setting the short protocol transmission Setting the reception of a short protocol transmission Setting the CNG detection times in the fax/telephone auto select mode	OFF ON ON 2TIME
	U633	Setting communication control 4 Enabling/disabling V.34 communication Setting the V.34 symbol speed (3429 Hz) Setting the number of times of DIS signal reception Setting the reference for RTN signal output	ON ON ONCE 15%
	U634	Setting communication control 5	0
	U640	Setting communication time 1 Setting the one-shot detection time for remote switching Setting the continuous detection time for remote switching	7 80
	U641	Setting communication time 2 Setting the T0 time-out time Setting the T1 time-out time Setting the T2 time-out time Setting the Ta time-out time Setting the Tb1 time-out time Setting the Tb2 time-out time Setting the Tc time-out time Setting the Td time-out time	56 36 69 30 20 80 60 9 (120 V) 6 (220-240 V)
	U650	Setting modem 1 Setting the G3 transmission cable equalizer Setting the G3 reception cable equalizer Setting the modem detection level	0dB 0dB 43dBm

Section	Item No.	Content of maintenance item	Initial setting
Fax	U651	Setting modem 2	9 (120 V)
		Modem output level	10 (220-240 V)
		DTMF output level (main value)	5 (120 V)
		DTMF output level (level difference)	10.5 (220-240 V)
	U660	Setting the NCU Setting the connection to PBX/PSTN Setting PSTN dial tone detection Setting busy tone detection Setting for a PBX Setting the loop current detection before dialing	PSTN ON ON LOOP ON
U670	Outputting lists	-	
U695	FAX function customize	ON/OFF	
U699	Setting the software switches	-	
Others	U910	Clearing the black ratio data	-
	U917	Setting backup data reading/writing	-
	U927	Clearing the all copy counts and machine life counts (one time only)	-
	U977	Data capture mode	-

(3) Contents of the maintenance mode items

Item No.	Description																
<p>U000</p>	<p>Outputting a maintenance report</p> <p>Description Outputs lists of the current settings of the maintenance items and paper jam and service call occurrences. Outputs the event log. Also sends output data to the USB memory. Printing a report is disabled either when a job is remaining in the buffer or when [Pause All Print Jobs] is pressed to halt printing.</p> <p>Purpose To check the current setting of the maintenance items, or paper jam or service call occurrences. Before initializing or replacing the backup RAM, output a list of the current settings of the maintenance items to reenter the settings after initialization or replacement.</p> <p>Method</p> <ol style="list-style-type: none"> 1. Press the start key. 2. Select the item to be output using the cursor up/down keys. <table border="1" data-bbox="336 819 1401 1010"> <thead> <tr> <th>Display</th> <th>Output list</th> </tr> </thead> <tbody> <tr> <td>MAINTENANCE</td> <td>List of the current settings of the maintenance modes</td> </tr> <tr> <td>EVENT</td> <td>Outputs the event log</td> </tr> <tr> <td>ALL</td> <td>Outputs the all reports</td> </tr> </tbody> </table> <ol style="list-style-type: none"> 3. Press the start key. A list is output. <p>Method: Send to the USB memory</p> <ol style="list-style-type: none"> 1. Turn the power switch off. 2. Insert USB memory in USB memory slot. 3. Turn the power switch on. 4. Enter the maintenance item. 5. Press the start key. 6. Select the item to be send. 7. Select [TEXT] or [HTML]. <table border="1" data-bbox="336 1375 1401 1565"> <thead> <tr> <th>Display</th> <th>Output list</th> </tr> </thead> <tbody> <tr> <td>Print</td> <td>Outputs the report</td> </tr> <tr> <td>USB (TEXT)</td> <td>Sends output data to the USB memory (text type)</td> </tr> <tr> <td>USB (HTML)</td> <td>Sends output data to the USB memory (HTML type)</td> </tr> </tbody> </table> <ol style="list-style-type: none"> 8. Press the start key. Output will be sent to the USB memory. <p>Completion Press the stop key. The screen for selecting a maintenance item No. is displayed.</p>	Display	Output list	MAINTENANCE	List of the current settings of the maintenance modes	EVENT	Outputs the event log	ALL	Outputs the all reports	Display	Output list	Print	Outputs the report	USB (TEXT)	Sends output data to the USB memory (text type)	USB (HTML)	Sends output data to the USB memory (HTML type)
Display	Output list																
MAINTENANCE	List of the current settings of the maintenance modes																
EVENT	Outputs the event log																
ALL	Outputs the all reports																
Display	Output list																
Print	Outputs the report																
USB (TEXT)	Sends output data to the USB memory (text type)																
USB (HTML)	Sends output data to the USB memory (HTML type)																

Item No.	Description																																																																																																																																																																																																																		
U000	<p data-bbox="287 241 414 273">Event log</p> <div data-bbox="327 309 1388 1601" style="border: 1px solid black; padding: 10px;"> <h3 data-bbox="351 331 574 376">Event Log</h3> <p data-bbox="351 385 414 407">MFP</p> <p data-bbox="1149 385 1364 407">(2) 06/Apr/2010 08:40</p> <p data-bbox="343 443 837 465">(1) Firmware Version 2MH_2000.000.000 2010.04.06</p> <p data-bbox="981 421 1364 465">(3) [XXXXXXXX] (4) [XXXXXXXX] (5) [XXXXXXXX]</p> <hr/> <div style="display: flex; justify-content: space-between;"> <div data-bbox="351 504 798 940"> <p data-bbox="351 504 558 526">(7) Paper Jam Log</p> <table border="1"> <thead> <tr> <th>#</th> <th>Count.</th> <th>Event Descriptions</th> </tr> </thead> <tbody> <tr><td>16</td><td>1876543</td><td>1000.01.08.01.01</td></tr> <tr><td>15</td><td>166554</td><td>1000.01.08.01.02</td></tr> <tr><td>14</td><td>4988</td><td>1000.01.08.01.01</td></tr> <tr><td>13</td><td>4988</td><td>1000.01.08.01.02</td></tr> <tr><td>12</td><td>4988</td><td>1000.01.08.01.01</td></tr> <tr><td>11</td><td>4988</td><td>1000.01.08.01.02</td></tr> <tr><td>10</td><td>1103</td><td>1000.01.08.01.01</td></tr> <tr><td>9</td><td>1103</td><td>1000.01.08.01.02</td></tr> <tr><td>8</td><td>1103</td><td>1000.01.08.01.01</td></tr> <tr><td>7</td><td>1103</td><td>1000.01.08.01.02</td></tr> <tr><td>6</td><td>1027</td><td>1000.01.08.01.01</td></tr> <tr><td>5</td><td>1027</td><td>1000.01.08.01.02</td></tr> <tr><td>4</td><td>1027</td><td>1000.01.08.01.01</td></tr> <tr><td>3</td><td>1027</td><td>1000.01.08.01.02</td></tr> <tr><td>2</td><td>406</td><td>1000.01.08.01.01</td></tr> <tr><td>1</td><td>36</td><td>1000.01.08.01.02</td></tr> </tbody> </table> </div> <div data-bbox="893 504 1276 750"> <p data-bbox="893 504 1117 526">(8) Service Call Log</p> <table border="1"> <thead> <tr> <th>#</th> <th>Count.</th> <th>Service Code</th> </tr> </thead> <tbody> <tr><td>8</td><td>1881214</td><td>01.0030</td></tr> <tr><td>7</td><td>178944</td><td>01.1010</td></tr> <tr><td>6</td><td>5296</td><td>01.4000</td></tr> <tr><td>5</td><td>5295</td><td>01.3100</td></tr> <tr><td>4</td><td>2099</td><td>01.2000</td></tr> <tr><td>3</td><td>1054</td><td>01.2000</td></tr> <tr><td>2</td><td>809</td><td>01.2500</td></tr> <tr><td>1</td><td>30</td><td>01.2500</td></tr> </tbody> </table> </div> <div data-bbox="893 761 1197 996"> <p data-bbox="893 761 1117 784">(9) Maintenance Log</p> <table border="1"> <thead> <tr> <th>#</th> <th>Count.</th> <th>Item</th> </tr> </thead> <tbody> <tr><td>8</td><td>1045571</td><td>01.00</td></tr> <tr><td>7</td><td>104511</td><td>01.00</td></tr> <tr><td>6</td><td>7045</td><td>01.00</td></tr> <tr><td>5</td><td>3454</td><td>01.00</td></tr> <tr><td>4</td><td>3454</td><td>02.00</td></tr> <tr><td>3</td><td>3454</td><td>02.00</td></tr> <tr><td>2</td><td>417</td><td>02.00</td></tr> <tr><td>1</td><td>34</td><td>02.20</td></tr> </tbody> </table> </div> <div data-bbox="893 1008 1197 1176"> <p data-bbox="893 1008 1149 1030">(10) Unknown Toner Log</p> <table border="1"> <thead> <tr> <th>#</th> <th>Count.</th> <th>Item</th> </tr> </thead> <tbody> <tr><td>5</td><td>3454</td><td>01.00</td></tr> <tr><td>4</td><td>3454</td><td>01.00</td></tr> <tr><td>3</td><td>3454</td><td>01.00</td></tr> <tr><td>2</td><td>406</td><td>01.00</td></tr> <tr><td>1</td><td>32</td><td>01.00</td></tr> </tbody> </table> </div> </div> <div style="text-align: center; margin: 10px 0;"> <table border="1" data-bbox="510 985 861 1075"> <tr> <td colspan="5" style="text-align: center;">1000.01.08.01.01</td> </tr> <tr> <td style="text-align: center;">(a)</td> <td style="text-align: center;">(b)</td> <td style="text-align: center;">(c)</td> <td style="text-align: center;">(d)</td> <td style="text-align: center;">(e)</td> </tr> </table> </div> <div data-bbox="335 1198 909 1500"> <p data-bbox="335 1198 526 1220">(11) Counter Log</p> <table border="1"> <thead> <tr> <th>(f)</th> <th>J0030:000</th> <th>(g)</th> <th>C0030:001</th> <th>C2000:001</th> <th>(h)</th> <th>M00:01</th> </tr> </thead> <tbody> <tr> <td>J0010:000</td> <td>J0031:000</td> <td>C0070:001</td> <td>C2200:001</td> <td>M00:01</td> <td></td> <td></td> </tr> <tr> <td>J0011:000</td> <td>J0032:000</td> <td>C0100:001</td> <td>C3100:001</td> <td></td> <td></td> <td></td> </tr> <tr> <td>J0012:000</td> <td>J0040:000</td> <td>C0120:001</td> <td>C3200:001</td> <td></td> <td></td> <td></td> </tr> <tr> <td>J0020:000</td> <td>J0041:002</td> <td>C0130:001</td> <td>C3300:001</td> <td></td> <td></td> <td></td> </tr> <tr> <td>J0021:002</td> <td></td> <td></td> <td></td> <td></td> <td></td> <td></td> </tr> <tr> <td>.</td> <td>.</td> <td>.</td> <td>.</td> <td>.</td> <td>.</td> <td>.</td> </tr> <tr> <td>.</td> <td>.</td> <td>.</td> <td>.</td> <td>.</td> <td>.</td> <td>.</td> </tr> <tr> <td>.</td> <td>.</td> <td>.</td> <td>.</td> <td>.</td> <td>.</td> <td>.</td> </tr> <tr> <td>.</td> <td>.</td> <td>.</td> <td>.</td> <td>.</td> <td>.</td> <td>.</td> </tr> <tr> <td>.</td> <td>.</td> <td>.</td> <td>.</td> <td>.</td> <td>.</td> <td>.</td> </tr> </tbody> </table> </div> <p data-bbox="1085 1556 1356 1579" style="text-align: right;">(6) [XXXXXXXXXXXXXXXXXXXX]</p> </div>	#	Count.	Event Descriptions	16	1876543	1000.01.08.01.01	15	166554	1000.01.08.01.02	14	4988	1000.01.08.01.01	13	4988	1000.01.08.01.02	12	4988	1000.01.08.01.01	11	4988	1000.01.08.01.02	10	1103	1000.01.08.01.01	9	1103	1000.01.08.01.02	8	1103	1000.01.08.01.01	7	1103	1000.01.08.01.02	6	1027	1000.01.08.01.01	5	1027	1000.01.08.01.02	4	1027	1000.01.08.01.01	3	1027	1000.01.08.01.02	2	406	1000.01.08.01.01	1	36	1000.01.08.01.02	#	Count.	Service Code	8	1881214	01.0030	7	178944	01.1010	6	5296	01.4000	5	5295	01.3100	4	2099	01.2000	3	1054	01.2000	2	809	01.2500	1	30	01.2500	#	Count.	Item	8	1045571	01.00	7	104511	01.00	6	7045	01.00	5	3454	01.00	4	3454	02.00	3	3454	02.00	2	417	02.00	1	34	02.20	#	Count.	Item	5	3454	01.00	4	3454	01.00	3	3454	01.00	2	406	01.00	1	32	01.00	1000.01.08.01.01					(a)	(b)	(c)	(d)	(e)	(f)	J0030:000	(g)	C0030:001	C2000:001	(h)	M00:01	J0010:000	J0031:000	C0070:001	C2200:001	M00:01			J0011:000	J0032:000	C0100:001	C3100:001				J0012:000	J0040:000	C0120:001	C3200:001				J0020:000	J0041:002	C0130:001	C3300:001				J0021:002						
#	Count.	Event Descriptions																																																																																																																																																																																																																	
16	1876543	1000.01.08.01.01																																																																																																																																																																																																																	
15	166554	1000.01.08.01.02																																																																																																																																																																																																																	
14	4988	1000.01.08.01.01																																																																																																																																																																																																																	
13	4988	1000.01.08.01.02																																																																																																																																																																																																																	
12	4988	1000.01.08.01.01																																																																																																																																																																																																																	
11	4988	1000.01.08.01.02																																																																																																																																																																																																																	
10	1103	1000.01.08.01.01																																																																																																																																																																																																																	
9	1103	1000.01.08.01.02																																																																																																																																																																																																																	
8	1103	1000.01.08.01.01																																																																																																																																																																																																																	
7	1103	1000.01.08.01.02																																																																																																																																																																																																																	
6	1027	1000.01.08.01.01																																																																																																																																																																																																																	
5	1027	1000.01.08.01.02																																																																																																																																																																																																																	
4	1027	1000.01.08.01.01																																																																																																																																																																																																																	
3	1027	1000.01.08.01.02																																																																																																																																																																																																																	
2	406	1000.01.08.01.01																																																																																																																																																																																																																	
1	36	1000.01.08.01.02																																																																																																																																																																																																																	
#	Count.	Service Code																																																																																																																																																																																																																	
8	1881214	01.0030																																																																																																																																																																																																																	
7	178944	01.1010																																																																																																																																																																																																																	
6	5296	01.4000																																																																																																																																																																																																																	
5	5295	01.3100																																																																																																																																																																																																																	
4	2099	01.2000																																																																																																																																																																																																																	
3	1054	01.2000																																																																																																																																																																																																																	
2	809	01.2500																																																																																																																																																																																																																	
1	30	01.2500																																																																																																																																																																																																																	
#	Count.	Item																																																																																																																																																																																																																	
8	1045571	01.00																																																																																																																																																																																																																	
7	104511	01.00																																																																																																																																																																																																																	
6	7045	01.00																																																																																																																																																																																																																	
5	3454	01.00																																																																																																																																																																																																																	
4	3454	02.00																																																																																																																																																																																																																	
3	3454	02.00																																																																																																																																																																																																																	
2	417	02.00																																																																																																																																																																																																																	
1	34	02.20																																																																																																																																																																																																																	
#	Count.	Item																																																																																																																																																																																																																	
5	3454	01.00																																																																																																																																																																																																																	
4	3454	01.00																																																																																																																																																																																																																	
3	3454	01.00																																																																																																																																																																																																																	
2	406	01.00																																																																																																																																																																																																																	
1	32	01.00																																																																																																																																																																																																																	
1000.01.08.01.01																																																																																																																																																																																																																			
(a)	(b)	(c)	(d)	(e)																																																																																																																																																																																																															
(f)	J0030:000	(g)	C0030:001	C2000:001	(h)	M00:01																																																																																																																																																																																																													
J0010:000	J0031:000	C0070:001	C2200:001	M00:01																																																																																																																																																																																																															
J0011:000	J0032:000	C0100:001	C3100:001																																																																																																																																																																																																																
J0012:000	J0040:000	C0120:001	C3200:001																																																																																																																																																																																																																
J0020:000	J0041:002	C0130:001	C3300:001																																																																																																																																																																																																																
J0021:002																																																																																																																																																																																																																			
.																																																																																																																																																																																																													
.																																																																																																																																																																																																													
.																																																																																																																																																																																																													
.																																																																																																																																																																																																													
.																																																																																																																																																																																																													

Figure 1-3-1

Item No.	Description												
U000	Detail of event log												
	No.	Items	Description										
	(1)	System version											
	(2)	System date											
	(3)	Engine soft version											
	(4)	Engine boot version											
	(5)	Operation panel mask version											
	(6)	Machine serial number											
	(7)	Paper Jam Log	<table border="1"> <thead> <tr> <th data-bbox="544 640 844 674">#</th> <th data-bbox="849 640 1114 674">Count.</th> <th data-bbox="1114 640 1439 674">Event</th> </tr> </thead> <tbody> <tr> <td data-bbox="544 674 844 994">Remembers 1 to 16 of occurrence. If the occurrence of the previous paper jam is less than 16, all of the paper jams are logged. When the occurrence exceeds 16, the oldest occurrence is removed.</td> <td data-bbox="849 674 1114 994">The total page count at the time of the paper jam.</td> <td data-bbox="1114 674 1439 994"> Log code (2 digit, hexadecimal, 5 categories) (a) Cause of a paper jam (b) Paper source (c) Paper size (d) Paper type (e) Paper eject </td> </tr> <tr> <td colspan="3" data-bbox="544 994 1439 1046">(a) Cause of paper jam (Hexadecimal)</td> </tr> </tbody> </table>	#	Count.	Event	Remembers 1 to 16 of occurrence. If the occurrence of the previous paper jam is less than 16, all of the paper jams are logged. When the occurrence exceeds 16, the oldest occurrence is removed.	The total page count at the time of the paper jam.	Log code (2 digit, hexadecimal, 5 categories) (a) Cause of a paper jam (b) Paper source (c) Paper size (d) Paper type (e) Paper eject	(a) Cause of paper jam (Hexadecimal)			Refer to page 1-4-2 for paper jam location 0100: Secondary paper feed request time out 0101: Waiting for process package to be ready 0105: Warm up request time out 0107: Waiting for fuser package to be ready 0110: Top cover open 0501: No paper feed from cassette 1 0502: No paper feed from cassette 2 0503: No paper feed from cassette 3 0508: No paper feed from duplex section 0509: No paper feed from MP tray 0511: Multiple sheets in cassette 1 0512: Multiple sheets in cassette 2 0513: Multiple sheets in cassette 3 0518: Multiple sheets in duplex section 0519: Multiple sheets in MP tray 1403: PF feed sensor 1 non arrival jam (cassette 3) 1413: PF feed sensor 1 stay jam (cassette 3) 1420: PF feed sensor 1 initial jam (Warm up) 1620: PF feed sensor 2 initial jam (Warm up) 4002: Registration sensor non arrival jam (cassette 2) 4003: Registration sensor non arrival jam (cassette 3) 4012: Registration sensor stay jam (cassette 2) 4013: Registration sensor stay jam (cassette 3) 4020: Registration sensor initial jam (Warm up) 4201: Eject sensor non arrival jam (cassette 1) 4202: Eject sensor non arrival jam (cassette 2) 4203: Eject sensor non arrival jam (cassette 3)
	#	Count.	Event										
	Remembers 1 to 16 of occurrence. If the occurrence of the previous paper jam is less than 16, all of the paper jams are logged. When the occurrence exceeds 16, the oldest occurrence is removed.	The total page count at the time of the paper jam.	Log code (2 digit, hexadecimal, 5 categories) (a) Cause of a paper jam (b) Paper source (c) Paper size (d) Paper type (e) Paper eject										
	(a) Cause of paper jam (Hexadecimal)												

Item No.	Description	
<p>U000</p>	<p>No.</p>	<p>Items</p>
	<p>Description</p>	<p>Description</p>
	<p>(7) cont.</p> <p>Paper Jam Log</p>	<p>4208: Eject sensor non arrival jam (duplex) 4209: Eject sensor non arrival jam (Mp tray) 4211: Eject sensor stay jam (cassette 1) 4212: Eject sensor stay jam (cassette 2) 4213: Eject sensor stay jam (cassette 3) 4218: Eject sensor stay jam (duplex) 4219: Eject sensor stay jam (MP tray) 4220: Eject sensor initial jam (Warm up) 4301: Duplex sensor non arrival jam (cassette 1) 4302: Duplex sensor non arrival jam (cassette 2) 4303: Duplex sensor non arrival jam (cassette 3) 4308: Duplex sensor non arrival jam (duplex) 4309: Duplex sensor non arrival jam (MP tray) 4311: Duplex sensor stay jam (cassette 1) 4312: Duplex sensor stay jam (cassette 2) 4313: Duplex sensor stay jam (cassette 3) 4318: Duplex sensor stay jam (duplex) 4319: Duplex sensor stay jam (MP tray) 9000: No original feed 9001: DP original conveying jam 9003: DP original swichback non arrival jam 9004: DP original swichback stay jam 9011: DP top cover open 9410: DP timing sensor stay jam</p> <hr/> <p>(b) Detail of paper source (Hexadecimal)</p> <p>00: MP tray 01: Cassette 1 02: Cassette 2 (paper feeder 1) 03: Cassette 3 (paper feeder 2) 04: Cassette 4 (paper feeder 3) 05 to 09: Reserved</p>

Item No.	Description				
U000	(7) cont.	Paper Jam Log	Description		
			(c) Detail of paper size (Hexadecimal)		
			00: (Not specified)	0B: B4	22: Special 1
			01: Monarch	0C: Ledger	23: Special 2
			02: Business	0D: A5R	24: A3 wide
			03: International DL	0E: A6	25: Ledger wide
			04: International C5	0F: B6	26: Full bleed paper (12 x 8)
			05: Executive	10: Commercial #9	27: 8K
			06: Letter-R	11: Commercial #6	28: 16K-R
			86: Letter-E	12: ISO B5	2A: 216x340mm
			07: Legal	13: Custom size	A8: 16K-E
			08: A4R	1E: C4	32: Statement-R
			88: A4E	1F: Postcard	B2: Statement-E
			09: B5R	20: Reply-paid post- card	33: Folio
			89: B5E	21: Oficio II	34: Western type 2
			0A: A3		35: Western type 4
			(d) Detail of paper type (Hexadecimal)		
			01: Plain	0A: Color	15: Custom 1
			02: Transparency	0B: Prepunched	16: Custom 2
			03: Preprinted	0C: Envelope	17: Custom 3
			04: Labels	0D: Cardstock	18: Custom 4
			05: Bond	0E: Coated	19: Custom 5
			06: Recycled	0F: 2nd side	1A: Custom 6
			07: Vellum	10: Media 16	1B: Custom 7
			08: Rough	11: High quality	1C: Custom 8
			09: Letterhead		
			(e) Detail of paper eject location (Hexadecimal)		
			01: Face down (FD)		
(8)	Service Call Log	#	Count.	Service Code	
		Remembers 1 to 8 of occurrence of self diagnostics error. If the occurrence of the previous diagnostics error is less than 8, all of the diagnostics errors are logged.	The total page count at the time of the self diagnostics error.	Self diagnostic error code (See page 1-4-4) Example: 01.6000 01: Self diagnostic error 6000: Self diagnostic error code number	

Item No.	Description								
U000	<table border="1"> <thead> <tr> <th data-bbox="295 280 375 324">No.</th> <th data-bbox="375 280 590 324">Items</th> <th colspan="3" data-bbox="590 280 1444 324">Description</th> </tr> </thead> </table>				No.	Items	Description		
	No.	Items	Description						
	(9)	Maintenance Log	<p>#</p> <p>Remembers 1 to 8 of occurrence of replacement. If the occurrence of the previous replacement of toner container is less than 8, all of the occurrences of replacement are logged.</p>	<p>Count.</p> <p>The total page count at the time of the replacement of the toner container.</p>	<p>Item</p> <p>Code of maintenance replacing item (1 byte, 2 categories)</p> <p>First byte (Replacing item) 01: Toner container 02: Maintenance kit</p> <p>Second byte (Type of replacing item) 00: Black 01: MK-1130/1140 MK-1132/1142</p>				
	(10)	Unknown Toner Log	<p>#</p> <p>Remembers 1 to 5 of occurrence of unknown toner detection. If the occurrence of the previous unknown toner detection is less than 5, all of the unknown toner detection are logged.</p>	<p>Count.</p> <p>The total page count at the time of the [Toner Empty] error with using an unknown toner container.</p>	<p>Item</p> <p>Unknown toner log code (1 byte, 2 categories)</p> <p>First byte 01: Fixed (Toner container)</p> <p>Second byte 00: Fixed (Black)</p>				
	(11)	<p>Counter Log</p> <p>Comprised of three log counters including paper jams, self diagnostics errors, and replacement of the toner container.</p>	<p>(f) Paper jam</p> <p>Indicates the log counter of paper jams depending on location.</p> <p>Refer to Paper Jam Log.</p> <p>All instances including those are not occurred are displayed.</p>	<p>(g) Self diagnostic error</p> <p>Indicates the log counter of self diagnostics errors depending on cause.</p> <p>(See page 1-4-4)</p> <p>Example: C6000: 4</p> <p>Self diagnostics error 6000 has happened four times.</p>	<p>(h) Maintenance item replacing</p> <p>Indicates the log counter depending on the maintenance item for maintenance.</p> <p>T: Toner container 00: Black M: Maintenance kit 00: MK-1130/1140 MK-1132/1142</p> <p>Example: T00: 1 The toner container has been replaced once.</p>				

Item No.	Description										
U002	<p>Setting the factory default data</p> <p>Description Restores the machine conditions to the factory default settings.</p> <p>Purpose To move the image scanner unit to the home position. (position in which the frame can be fixed).</p> <p>Method</p> <ol style="list-style-type: none"> 1. Press the start key. 2. Select [MODE1(ALL)] using the cursor up/down keys. 3. Press the start key. The image scanner returns to the home position. 4. Turn the power switch off and on. * : An error code is displayed in case of an initialization error. When errors occurred, turn power switch off then on, and execute initialization using maintenance item U002. <p>Error codes</p> <table border="1" data-bbox="335 873 1404 1064"> <thead> <tr> <th>Codes</th> <th>Description</th> </tr> </thead> <tbody> <tr> <td>0001</td> <td>Controller error</td> </tr> <tr> <td>0020</td> <td>Engine error</td> </tr> <tr> <td>0040</td> <td>Scanner error</td> </tr> </tbody> </table>	Codes	Description	0001	Controller error	0020	Engine error	0040	Scanner error		
Codes	Description										
0001	Controller error										
0020	Engine error										
0040	Scanner error										
U004	<p>Setting the machine number</p> <p>Description Sets or displays the machine number.</p> <p>Purpose To check or set the machine number.</p> <p>Method</p> <ol style="list-style-type: none"> 1. Press the start key. If the machine serial number of engine PWB matches with that of main PWB <table border="1" data-bbox="347 1422 1412 1505"> <thead> <tr> <th>Display</th> <th>Operation</th> </tr> </thead> <tbody> <tr> <td>MACHINE No.</td> <td>Displays the machine serial number</td> </tr> </tbody> </table> <p>If the machine serial number of engine PWB does not match with that of main PWB</p> <table border="1" data-bbox="347 1556 1412 1684"> <thead> <tr> <th>Display</th> <th>Operation</th> </tr> </thead> <tbody> <tr> <td>MACHINE No. (MAIN)</td> <td>Displays the machine serial number of main</td> </tr> <tr> <td>MACHINE No. (ENG)</td> <td>Displays the machine serial number of engine</td> </tr> </tbody> </table> <p>Setting Carry out if the machine serial number does not match.</p> <ol style="list-style-type: none"> 1. Press [EXECUTE]. 2. Press the start key. Writing of serial No. starts. <p>Completion Press the stop key. The screen for selecting a maintenance item No. is displayed.</p>	Display	Operation	MACHINE No.	Displays the machine serial number	Display	Operation	MACHINE No. (MAIN)	Displays the machine serial number of main	MACHINE No. (ENG)	Displays the machine serial number of engine
Display	Operation										
MACHINE No.	Displays the machine serial number										
Display	Operation										
MACHINE No. (MAIN)	Displays the machine serial number of main										
MACHINE No. (ENG)	Displays the machine serial number of engine										

Item No.	Description																
U203	<p data-bbox="287 241 587 275">Checking DP operation</p> <p data-bbox="287 313 440 342">Description</p> <p data-bbox="287 344 1046 376">Simulates the original conveying operation separately in the DP.</p> <p data-bbox="287 383 400 412">Purpose</p> <p data-bbox="287 416 612 448">To check the DP operation.</p> <p data-bbox="287 486 387 515">Method</p> <ol data-bbox="304 519 1094 620" style="list-style-type: none"> 1. Press the start key. 2. Place an original in the DP if running this simulation with paper. 3. Select the speed to be operated using the cursor up/down keys. <table border="1" data-bbox="336 631 1401 777"> <thead> <tr> <th data-bbox="336 631 639 676">Display</th> <th data-bbox="639 631 1401 676">Description</th> </tr> </thead> <tbody> <tr> <td data-bbox="336 676 639 721">NORMAL SPEED</td> <td data-bbox="639 676 1401 721">Normal reading (600 dpi)</td> </tr> <tr> <td data-bbox="336 721 639 777">HIGH SPEED</td> <td data-bbox="639 721 1401 777">High-speed reading</td> </tr> </tbody> </table> <ol data-bbox="304 786 1070 851" style="list-style-type: none"> 4. Press the start key. 5. Select the item to be operated using the cursor up/down keys. <table border="1" data-bbox="336 862 1401 1173"> <thead> <tr> <th data-bbox="336 862 639 907">Display</th> <th data-bbox="639 862 1401 907">Description</th> </tr> </thead> <tbody> <tr> <td data-bbox="336 907 639 994">CCD ADP (NON P)</td> <td data-bbox="639 907 1401 994">Without paper, single-sided original of CCD (continuous operation)</td> </tr> <tr> <td data-bbox="336 994 639 1039">CCD ADP</td> <td data-bbox="639 994 1401 1039">With paper, single-sided original of CCD</td> </tr> <tr> <td data-bbox="336 1039 639 1126">CCD RADP (NON P)</td> <td data-bbox="639 1039 1401 1126">Without paper, double-sided original of CCD (continuous operation)</td> </tr> <tr> <td data-bbox="336 1126 639 1173">CCD RADP</td> <td data-bbox="639 1126 1401 1173">With paper, double-sided original of CCD</td> </tr> </tbody> </table> <ol data-bbox="304 1182 919 1252" style="list-style-type: none"> 6. Press the start key. The operation starts. 7. To stop continuous operation, press the stop key. <p data-bbox="287 1288 440 1317">Completion</p> <p data-bbox="287 1321 1257 1352">Press the stop key. The screen for selecting a maintenance item No. is displayed.</p>	Display	Description	NORMAL SPEED	Normal reading (600 dpi)	HIGH SPEED	High-speed reading	Display	Description	CCD ADP (NON P)	Without paper, single-sided original of CCD (continuous operation)	CCD ADP	With paper, single-sided original of CCD	CCD RADP (NON P)	Without paper, double-sided original of CCD (continuous operation)	CCD RADP	With paper, double-sided original of CCD
Display	Description																
NORMAL SPEED	Normal reading (600 dpi)																
HIGH SPEED	High-speed reading																
Display	Description																
CCD ADP (NON P)	Without paper, single-sided original of CCD (continuous operation)																
CCD ADP	With paper, single-sided original of CCD																
CCD RADP (NON P)	Without paper, double-sided original of CCD (continuous operation)																
CCD RADP	With paper, double-sided original of CCD																

Item No.	Description						
U222	<p>Setting the IC card type</p> <p>Description Sets the type of IC card.</p> <p>Purpose To change the type of IC card.</p> <p>Setting</p> <ol style="list-style-type: none"> 1. Press the start key. 2. Select the item using the cursor up/down keys. <table border="1" data-bbox="335 593 1401 739"> <thead> <tr> <th>Display</th> <th>Description</th> </tr> </thead> <tbody> <tr> <td>OTHER</td> <td>The type of IC card is SSFC.</td> </tr> <tr> <td>SSFC</td> <td>The type of IC card is not SSFC.</td> </tr> </tbody> </table> <p>* : Initial setting: OTHER</p> <ol style="list-style-type: none"> 3. Press the start key. The setting is set. <p>Completion Press the stop key. The screen for selecting a maintenance item No. is displayed.</p>	Display	Description	OTHER	The type of IC card is SSFC.	SSFC	The type of IC card is not SSFC.
Display	Description						
OTHER	The type of IC card is SSFC.						
SSFC	The type of IC card is not SSFC.						
U250	<p>Setting the maintenance cycle</p> <p>Description Displays, clears and changes the maintenance cycle.</p> <p>Purpose To check and change the maintenance cycle.</p> <p>Method</p> <ol style="list-style-type: none"> 1. Press the start key. The currently set maintenance cycle is displayed. <p>Setting</p> <ol style="list-style-type: none"> 1. Select [M.CNT A] using the cursor up/down keys. 2. Change the setting using the cursor left/right keys or numeric keys. <table border="1" data-bbox="335 1400 1401 1489"> <thead> <tr> <th>Description</th> <th>Setting range</th> <th>Initial setting</th> </tr> </thead> <tbody> <tr> <td>Maintenance cycle</td> <td>0 to 9999999</td> <td>100000</td> </tr> </tbody> </table> <ol style="list-style-type: none"> 3. Press the start key. The value is set. <p>Clearing</p> <ol style="list-style-type: none"> 1. Select [CLEAR] using the cursor up/down keys. 2. Press the start key. The count is cleared. <p>Completion Press the stop key. The screen for selecting a maintenance item No. is displayed.</p>	Description	Setting range	Initial setting	Maintenance cycle	0 to 9999999	100000
Description	Setting range	Initial setting					
Maintenance cycle	0 to 9999999	100000					

Item No.	Description						
U251	<p data-bbox="287 241 821 275">Checking/clearing the maintenance count</p> <p data-bbox="287 313 438 342">Description Displays, clears and changes the maintenance count.</p> <p data-bbox="287 380 399 409">Purpose To check the maintenance count. Also to clear the count during maintenance service (replacing the maintenance kit).</p> <p data-bbox="287 515 391 544">Method 1. Press the start key. The maintenance count is displayed.</p> <p data-bbox="287 622 383 651">Setting 1. Select [M.CNT A] using the cursor up/down keys. 2. Change the setting using the cursor left/right keys or numeric keys.</p> <table border="1" data-bbox="335 734 1401 828"> <thead> <tr> <th data-bbox="343 741 869 779">Description</th> <th data-bbox="869 741 1133 779">Setting range</th> <th data-bbox="1133 741 1401 779">Initial setting</th> </tr> </thead> <tbody> <tr> <td data-bbox="343 786 869 824">Maintenance count</td> <td data-bbox="869 786 1133 824">0 to 9999999</td> <td data-bbox="1133 786 1401 824">0</td> </tr> </tbody> </table> <p data-bbox="287 840 766 869">3. Press the start key. The count is set.</p> <p data-bbox="287 907 399 936">Clearing 1. Select [CLEAR] using the cursor up/down keys. 2. Press the start key. The count is cleared.</p> <p data-bbox="287 1041 438 1070">Completion Press the stop key. The screen for selecting a maintenance item No. is displayed.</p>	Description	Setting range	Initial setting	Maintenance count	0 to 9999999	0
Description	Setting range	Initial setting					
Maintenance count	0 to 9999999	0					

Item No.	Description														
<p>U252</p>	<p>Setting the destination</p> <p>Description Switches the operations and screens of the machine according to the destination.</p> <p>Purpose To be executed after initializing the backup RAM, in order to return the setting to the value before replacement or initialization.</p> <p>Setting</p> <ol style="list-style-type: none"> 1. Press the start key. 2. Select the destination using the cursor up/down keys. <table border="1" data-bbox="347 629 1414 920"> <thead> <tr> <th>Display</th> <th>Description</th> </tr> </thead> <tbody> <tr> <td>INCH</td> <td>Inch (North America) specifications</td> </tr> <tr> <td>EUROPE METRIC</td> <td>Metric (Europe) specifications</td> </tr> <tr> <td>ASIA PACIFIC</td> <td>Metric (Asia Pacific) specifications</td> </tr> <tr> <td>AUSTRALIA</td> <td>Australia specifications</td> </tr> <tr> <td>CHINA</td> <td>China specifications</td> </tr> <tr> <td>KOREA</td> <td>Korea specifications</td> </tr> </tbody> </table> <ol style="list-style-type: none"> 3. Press the start key. 4. Turn the power switch off and on. 	Display	Description	INCH	Inch (North America) specifications	EUROPE METRIC	Metric (Europe) specifications	ASIA PACIFIC	Metric (Asia Pacific) specifications	AUSTRALIA	Australia specifications	CHINA	China specifications	KOREA	Korea specifications
Display	Description														
INCH	Inch (North America) specifications														
EUROPE METRIC	Metric (Europe) specifications														
ASIA PACIFIC	Metric (Asia Pacific) specifications														
AUSTRALIA	Australia specifications														
CHINA	China specifications														
KOREA	Korea specifications														
<p>U253</p>	<p>Switching between double and single counts</p> <p>Description Switches the count system for the total counter and other counters.</p> <p>Purpose Used to select, according to the preference of the user (copy service provider), if folio size paper is to be counted as one sheet (single count) or two sheets (double count).</p> <p>Setting</p> <ol style="list-style-type: none"> 1. Press the start key. 2. Select the count system using the cursor up/down keys. <table border="1" data-bbox="336 1469 1402 1615"> <thead> <tr> <th>Display</th> <th>Description</th> </tr> </thead> <tbody> <tr> <td>SGL COUNT(ALL)</td> <td>Single count for all size paper</td> </tr> <tr> <td>DBL COUNT(FOLIO)</td> <td>Double count for Folio size or larger</td> </tr> </tbody> </table> <p>* : Initial setting: DBL COUNT(FOLIO)</p> <ol style="list-style-type: none"> 3. Press the start key. The setting is set. <p>Completion Press the stop key. The screen for selecting a maintenance item No. is displayed.</p>	Display	Description	SGL COUNT(ALL)	Single count for all size paper	DBL COUNT(FOLIO)	Double count for Folio size or larger								
Display	Description														
SGL COUNT(ALL)	Single count for all size paper														
DBL COUNT(FOLIO)	Double count for Folio size or larger														

Item No.	Description						
U260	<p>Selecting the timing for copy counting</p> <p>Description Changes the copy count timing for the total counter and other counters.</p> <p>Purpose To be set according to user request.</p> <p>Setting</p> <ol style="list-style-type: none"> 1. Press the start key. 2. Select the copy count timing using the cursor up/down keys. <table border="1" data-bbox="335 593 1401 739"> <thead> <tr> <th>Display</th> <th>Description</th> </tr> </thead> <tbody> <tr> <td>FEED</td> <td>When secondary paper feed starts</td> </tr> <tr> <td>EJECT</td> <td>When the paper is ejected</td> </tr> </tbody> </table> <p>* : Initial setting: EJECT</p> <ol style="list-style-type: none"> 3. Press the start key. The setting is set. <p>Completion Press the stop key. The screen for selecting a maintenance item No. is displayed.</p>	Display	Description	FEED	When secondary paper feed starts	EJECT	When the paper is ejected
Display	Description						
FEED	When secondary paper feed starts						
EJECT	When the paper is ejected						
U285	<p>Setting service status page</p> <p>Description Determines displaying the digital dot coverage report on reporting.</p> <p>Purpose According to user request, changes the setting.</p> <p>Setting</p> <ol style="list-style-type: none"> 1. Press the start key. 2. Select ON or OFF using the cursor up/down keys. <table border="1" data-bbox="335 1489 1401 1635"> <thead> <tr> <th>Display</th> <th>Description</th> </tr> </thead> <tbody> <tr> <td>ON</td> <td>Displays the digital dot coverage</td> </tr> <tr> <td>OFF</td> <td>Not to display the digital dot coverage</td> </tr> </tbody> </table> <p>* : Initial setting: ON</p> <ol style="list-style-type: none"> 3. Press the start key. The setting is set. <p>Completion Press the stop key. The screen for selecting a maintenance item No. is displayed.</p>	Display	Description	ON	Displays the digital dot coverage	OFF	Not to display the digital dot coverage
Display	Description						
ON	Displays the digital dot coverage						
OFF	Not to display the digital dot coverage						

Item No.	Description								
U332	<p>Setting the size conversion factor</p> <p>Description Sets the coefficient of nonstandard sizes in relation to the A4/Letter size. The coefficient set here is used to convert the black ratio in relation to the A4/Letter size and to display the result in user simulation.</p> <p>Purpose To set the coefficient for converting the black ratio for nonstandard sizes in relation to the A4/Letter size.</p> <p>Setting</p> <ol style="list-style-type: none"> 1. Press the start key. 2. Change the setting using the cursor left/right keys or numeric keys. <table border="1" data-bbox="335 698 1388 795"> <thead> <tr> <th>Display</th> <th>Description</th> <th>Setting range</th> <th>Initial setting</th> </tr> </thead> <tbody> <tr> <td>CALC.RATE</td> <td>Size parameter</td> <td>0.1 to 3.0</td> <td>1.0</td> </tr> </tbody> </table> <ol style="list-style-type: none"> 3. Press the start key. The value is set. <p>Completion Press the stop key. The screen for selecting a maintenance item No. is displayed.</p>	Display	Description	Setting range	Initial setting	CALC.RATE	Size parameter	0.1 to 3.0	1.0
Display	Description	Setting range	Initial setting						
CALC.RATE	Size parameter	0.1 to 3.0	1.0						
U345	<p>Setting the value for maintenance due indication</p> <p>Description Sets when to display a message notifying that the time for maintenance is about to be reached, by setting the number of copies that can be made before the current maintenance cycle ends. When the difference between the number of copies of the maintenance cycle and that of the maintenance count reaches the set value, the message is displayed.</p> <p>Purpose To change the time for maintenance due indication.</p> <p>Setting</p> <ol style="list-style-type: none"> 1. Press the start key. 2. Select [COUNT] using the cursor up/down keys. 3. Change the setting using the cursor left/right keys. <table border="1" data-bbox="335 1460 1401 1624"> <thead> <tr> <th>Description</th> <th>Setting range</th> <th>Initial setting</th> </tr> </thead> <tbody> <tr> <td>Time for maintenance due indication (Remaining number of copies that can be made before the current maintenance cycle ends)</td> <td>0 to 9999</td> <td>0</td> </tr> </tbody> </table> <ol style="list-style-type: none"> 4. Press the start key. The value is set. <p>Clearing</p> <ol style="list-style-type: none"> 1. Select [CLEAR] using the cursor up/down keys. 2. Press the start key. The value is cleared. <p>Completion Press the stop key. The screen for selecting a maintenance item No. is displayed.</p>	Description	Setting range	Initial setting	Time for maintenance due indication (Remaining number of copies that can be made before the current maintenance cycle ends)	0 to 9999	0		
Description	Setting range	Initial setting							
Time for maintenance due indication (Remaining number of copies that can be made before the current maintenance cycle ends)	0 to 9999	0							

Item No.	Description												
U411	<p data-bbox="288 241 753 275">Adjusting the scanner automatically</p> <p data-bbox="288 313 440 342">Description</p> <p data-bbox="288 347 1428 412">Uses a specified original and automatically adjusts the following items in the scanner and the DP scanning sections.</p> <p data-bbox="288 416 1428 481">Scanner section: Original size magnification, leading edge timing, center line, input gamma, input gamma in monochrome mode and matrix</p> <p data-bbox="288 486 1249 517">DP scanning section: Original size magnification, leading edge timing, center line</p> <p data-bbox="288 521 400 551">Purpose</p> <p data-bbox="288 555 1422 586">To perform automatic adjustment of various items in the scanner and the DP scanning sections.</p> <p data-bbox="288 624 387 654">Method</p> <ol data-bbox="304 658 979 723" style="list-style-type: none"> 1. Press the start key. 2. Select the item. The screen for executing is displayed. <table border="1" data-bbox="336 734 1401 1099"> <thead> <tr> <th data-bbox="336 734 564 817">Display</th> <th data-bbox="564 734 1098 817">Description</th> <th data-bbox="1098 734 1401 817">Original to be used for adjustment (P/N)</th> </tr> </thead> <tbody> <tr> <td data-bbox="336 817 564 936">ALL</td> <td data-bbox="564 817 1098 936">Performs automatic adjustment in the DP scanning section following automatic adjustment in the scanner section</td> <td data-bbox="1098 817 1401 936">302FZ56990/ 303LJ57010</td> </tr> <tr> <td data-bbox="336 936 564 1019">ADJUST TABLE</td> <td data-bbox="564 936 1098 1019">Automatic adjustment in the scanner section</td> <td data-bbox="1098 936 1401 1019">302FZ56990</td> </tr> <tr> <td data-bbox="336 1019 564 1099">ADJUST DP</td> <td data-bbox="564 1019 1098 1099">Automatic adjustment in the DP scanning section:</td> <td data-bbox="1098 1019 1401 1099">303LJ57010</td> </tr> </tbody> </table> <p data-bbox="288 1146 491 1176">Method: TABLE</p> <ol data-bbox="304 1180 1433 1559" style="list-style-type: none"> 1. Enter the target values which are shown on the specified original (P/N: 302FZ56990) executing maintenance item U425. 2. Set a specified original (P/N: 302FZ56990) on the platen. 3. Enter maintenance item U411. 4. Select [ADJUST TABLE] using the cursor up/down keys. 5. Press the start key. Auto adjustment starts. 6. When automatic adjustment has normally completed, [OK] is displayed. If a problem occurs during auto adjustment, [NG XX] (XX is replaced by an error code) is displayed and operation stops. Should this happen, determine the details of the problem and repeat the procedure from the beginning. 7. To return to the screen for selecting an item, press the stop key. <p data-bbox="288 1597 440 1626">Method: DP</p> <ol data-bbox="304 1630 1428 1906" style="list-style-type: none"> 1. Select [ADJUST DP] using the cursor up/down keys. 2. Set a specified original (P/N: 303LJ57010) in the DP. 3. Press the start key. Auto adjustment starts. 4. When automatic adjustment has normally completed, [OK] is displayed. If a problem occurs during auto adjustment, [NG XX] (XX is replaced by an error code) is displayed and operation stops. Should this happen, determine the details of the problem and repeat the procedure from the beginning. 5. To return to the screen for selecting an item, press the stop key. 	Display	Description	Original to be used for adjustment (P/N)	ALL	Performs automatic adjustment in the DP scanning section following automatic adjustment in the scanner section	302FZ56990/ 303LJ57010	ADJUST TABLE	Automatic adjustment in the scanner section	302FZ56990	ADJUST DP	Automatic adjustment in the DP scanning section:	303LJ57010
Display	Description	Original to be used for adjustment (P/N)											
ALL	Performs automatic adjustment in the DP scanning section following automatic adjustment in the scanner section	302FZ56990/ 303LJ57010											
ADJUST TABLE	Automatic adjustment in the scanner section	302FZ56990											
ADJUST DP	Automatic adjustment in the DP scanning section:	303LJ57010											

Item No.	Description																																																						
U411	Error Codes																																																						
	<table border="1"> <thead> <tr> <th data-bbox="335 280 486 324">Codes</th> <th data-bbox="486 280 1404 324">Description</th> </tr> </thead> <tbody> <tr> <td data-bbox="335 324 486 369">01</td> <td data-bbox="486 324 1404 369">Black band detection error (scanner leading edge registration)</td> </tr> <tr> <td data-bbox="335 369 486 414">02</td> <td data-bbox="486 369 1404 414">Black band detection error (scanner center line)</td> </tr> <tr> <td data-bbox="335 414 486 459">03</td> <td data-bbox="486 414 1404 459">Black band detection error (scanner main scanning direction magnification)</td> </tr> <tr> <td data-bbox="335 459 486 504">04</td> <td data-bbox="486 459 1404 504">Black band is not detected (scanner leading edge registration)</td> </tr> <tr> <td data-bbox="335 504 486 548">05</td> <td data-bbox="486 504 1404 548">Black band is not detected (scanner center line)</td> </tr> <tr> <td data-bbox="335 548 486 593">06</td> <td data-bbox="486 548 1404 593">Black band is not detected (scanner main scanning direction magnification)</td> </tr> <tr> <td data-bbox="335 593 486 638">07</td> <td data-bbox="486 593 1404 638">Black band is not detected (scanner auxiliary scanning direction magnification)</td> </tr> <tr> <td data-bbox="335 638 486 683">08</td> <td data-bbox="486 638 1404 683">Black band is not detected (DP main scanning direction magnification far end)</td> </tr> <tr> <td data-bbox="335 683 486 728">09</td> <td data-bbox="486 683 1404 728">Black band is not detected (DP main scanning direction magnification near end)</td> </tr> <tr> <td data-bbox="335 728 486 772">0a</td> <td data-bbox="486 728 1404 772">Black band is not detected (DP auxiliary scanning direction magnification leading edge)</td> </tr> <tr> <td data-bbox="335 772 486 817">0b</td> <td data-bbox="486 772 1404 817">Black band is not detected (DP auxiliary scanning direction magnification leading edge original check)</td> </tr> <tr> <td data-bbox="335 817 486 862">0c</td> <td data-bbox="486 817 1404 862">Black band is not detected (DP auxiliary scanning direction trailing edge)</td> </tr> <tr> <td data-bbox="335 862 486 907">0d</td> <td data-bbox="486 862 1404 907">Black band is not detected (DP auxiliary scanning direction trailing edge 2)</td> </tr> <tr> <td data-bbox="335 907 486 952">0e</td> <td data-bbox="486 907 1404 952">DMA time out</td> </tr> <tr> <td data-bbox="335 952 486 996">0f</td> <td data-bbox="486 952 1404 996">Auxiliary scanning direction magnification error</td> </tr> <tr> <td data-bbox="335 996 486 1041">10</td> <td data-bbox="486 996 1404 1041">Auxiliary scanning direction leading edge detection error</td> </tr> <tr> <td data-bbox="335 1041 486 1086">11</td> <td data-bbox="486 1041 1404 1086">Auxiliary scanning direction trailing edge detection error</td> </tr> <tr> <td data-bbox="335 1086 486 1131">12</td> <td data-bbox="486 1086 1404 1131">Auxiliary scanning direction skew 1.5 error</td> </tr> <tr> <td data-bbox="335 1131 486 1176">13</td> <td data-bbox="486 1131 1404 1176">Maintenance request error</td> </tr> <tr> <td data-bbox="335 1176 486 1220">14</td> <td data-bbox="486 1176 1404 1220">Main scanning direction center line error</td> </tr> <tr> <td data-bbox="335 1220 486 1265">15</td> <td data-bbox="486 1220 1404 1265">Main scanning direction skew 1.5 error</td> </tr> <tr> <td data-bbox="335 1265 486 1310">16</td> <td data-bbox="486 1265 1404 1310">Main scanning direction magnification error</td> </tr> <tr> <td data-bbox="335 1310 486 1355">17</td> <td data-bbox="486 1310 1404 1355">Service call error</td> </tr> <tr> <td data-bbox="335 1355 486 1400">18</td> <td data-bbox="486 1355 1404 1400">DP paper misfeed error</td> </tr> <tr> <td data-bbox="335 1400 486 1444">19</td> <td data-bbox="486 1400 1404 1444">PWB replacement error</td> </tr> <tr> <td data-bbox="335 1444 486 1489">1a</td> <td data-bbox="486 1444 1404 1489">Original error</td> </tr> </tbody> </table>	Codes	Description	01	Black band detection error (scanner leading edge registration)	02	Black band detection error (scanner center line)	03	Black band detection error (scanner main scanning direction magnification)	04	Black band is not detected (scanner leading edge registration)	05	Black band is not detected (scanner center line)	06	Black band is not detected (scanner main scanning direction magnification)	07	Black band is not detected (scanner auxiliary scanning direction magnification)	08	Black band is not detected (DP main scanning direction magnification far end)	09	Black band is not detected (DP main scanning direction magnification near end)	0a	Black band is not detected (DP auxiliary scanning direction magnification leading edge)	0b	Black band is not detected (DP auxiliary scanning direction magnification leading edge original check)	0c	Black band is not detected (DP auxiliary scanning direction trailing edge)	0d	Black band is not detected (DP auxiliary scanning direction trailing edge 2)	0e	DMA time out	0f	Auxiliary scanning direction magnification error	10	Auxiliary scanning direction leading edge detection error	11	Auxiliary scanning direction trailing edge detection error	12	Auxiliary scanning direction skew 1.5 error	13	Maintenance request error	14	Main scanning direction center line error	15	Main scanning direction skew 1.5 error	16	Main scanning direction magnification error	17	Service call error	18	DP paper misfeed error	19	PWB replacement error	1a	Original error
	Codes	Description																																																					
	01	Black band detection error (scanner leading edge registration)																																																					
	02	Black band detection error (scanner center line)																																																					
	03	Black band detection error (scanner main scanning direction magnification)																																																					
	04	Black band is not detected (scanner leading edge registration)																																																					
	05	Black band is not detected (scanner center line)																																																					
	06	Black band is not detected (scanner main scanning direction magnification)																																																					
	07	Black band is not detected (scanner auxiliary scanning direction magnification)																																																					
	08	Black band is not detected (DP main scanning direction magnification far end)																																																					
	09	Black band is not detected (DP main scanning direction magnification near end)																																																					
	0a	Black band is not detected (DP auxiliary scanning direction magnification leading edge)																																																					
	0b	Black band is not detected (DP auxiliary scanning direction magnification leading edge original check)																																																					
	0c	Black band is not detected (DP auxiliary scanning direction trailing edge)																																																					
	0d	Black band is not detected (DP auxiliary scanning direction trailing edge 2)																																																					
	0e	DMA time out																																																					
	0f	Auxiliary scanning direction magnification error																																																					
	10	Auxiliary scanning direction leading edge detection error																																																					
	11	Auxiliary scanning direction trailing edge detection error																																																					
	12	Auxiliary scanning direction skew 1.5 error																																																					
	13	Maintenance request error																																																					
	14	Main scanning direction center line error																																																					
	15	Main scanning direction skew 1.5 error																																																					
	16	Main scanning direction magnification error																																																					
	17	Service call error																																																					
	18	DP paper misfeed error																																																					
	19	PWB replacement error																																																					
1a	Original error																																																						
Completion																																																							
Press the stop key. The screen for selecting a maintenance item is displayed.																																																							

Item No.	Description																																		
U425	<p data-bbox="287 241 518 275">Setting the target</p> <p data-bbox="287 313 438 347">Description Enters the lab values that is indicated on the back of the chart (P/N: 302FZ56990) used for adjustment.</p> <p data-bbox="287 414 399 448">Purpose Performs data input in order to correct for differences in originals during automatic adjustment.</p> <p data-bbox="287 515 391 548">Method</p> <ol data-bbox="303 555 1005 622" style="list-style-type: none"> 1. Press the start key. 2. Select the item to be set using the cursor up/down keys. <table border="1" data-bbox="335 631 1401 1160"> <thead> <tr> <th data-bbox="343 638 638 683">Display</th> <th data-bbox="638 638 1396 683">Description</th> </tr> </thead> <tbody> <tr> <td data-bbox="343 683 638 728">N875</td> <td data-bbox="638 683 1396 728">Setting the N875 patch for the original for adjustment</td> </tr> <tr> <td data-bbox="343 728 638 772">N475</td> <td data-bbox="638 728 1396 772">Setting the N475 patch for the original for adjustment</td> </tr> <tr> <td data-bbox="343 772 638 817">N125</td> <td data-bbox="638 772 1396 817">Setting the N125 patch for the original for adjustment</td> </tr> <tr> <td data-bbox="343 817 638 862">CYAN</td> <td data-bbox="638 817 1396 862">Setting the cyan patch for the original for adjustment</td> </tr> <tr> <td data-bbox="343 862 638 907">MAGENTA</td> <td data-bbox="638 862 1396 907">Setting the magenta patch for the original for adjustment</td> </tr> <tr> <td data-bbox="343 907 638 952">YELLOW</td> <td data-bbox="638 907 1396 952">Setting the yellow patch for the original for adjustment</td> </tr> <tr> <td data-bbox="343 952 638 996">RED</td> <td data-bbox="638 952 1396 996">Setting the red patch for the original for adjustment</td> </tr> <tr> <td data-bbox="343 996 638 1041">GREEN</td> <td data-bbox="638 996 1396 1041">Setting the green patch for the original for adjustment</td> </tr> <tr> <td data-bbox="343 1041 638 1086">BLUE</td> <td data-bbox="638 1041 1396 1086">Setting the blue patch for the original for adjustment</td> </tr> <tr> <td data-bbox="343 1086 638 1153">ADJUST ORIGINAL</td> <td data-bbox="638 1086 1396 1153">Setting the main and auxiliary scanning directions</td> </tr> </tbody> </table> <ol data-bbox="303 1169 1005 1202" style="list-style-type: none"> 3. Select the item to be set using the cursor up/down keys. <table border="1" data-bbox="335 1211 1401 1406"> <thead> <tr> <th data-bbox="343 1218 638 1263">Display</th> <th data-bbox="638 1218 1021 1263">Description</th> <th data-bbox="1021 1218 1396 1263">Setting range</th> </tr> </thead> <tbody> <tr> <td data-bbox="343 1263 638 1308">L</td> <td data-bbox="638 1263 1021 1308">Setting the L value</td> <td data-bbox="1021 1263 1396 1308">0.0 to 100.0</td> </tr> <tr> <td data-bbox="343 1308 638 1352">a</td> <td data-bbox="638 1308 1021 1352">Setting the a value</td> <td data-bbox="1021 1308 1396 1352">-200.0 to 200.0</td> </tr> <tr> <td data-bbox="343 1352 638 1397">b</td> <td data-bbox="638 1352 1021 1397">Setting the b value</td> <td data-bbox="1021 1352 1396 1397">-200.0 to 200.0</td> </tr> </tbody> </table> <ol data-bbox="303 1415 1412 1516" style="list-style-type: none"> 4. Enters the value that is indicated on the back of the chart using the cursor left/right keys or numeric keys. 5. Press the start key. The value is set. 	Display	Description	N875	Setting the N875 patch for the original for adjustment	N475	Setting the N475 patch for the original for adjustment	N125	Setting the N125 patch for the original for adjustment	CYAN	Setting the cyan patch for the original for adjustment	MAGENTA	Setting the magenta patch for the original for adjustment	YELLOW	Setting the yellow patch for the original for adjustment	RED	Setting the red patch for the original for adjustment	GREEN	Setting the green patch for the original for adjustment	BLUE	Setting the blue patch for the original for adjustment	ADJUST ORIGINAL	Setting the main and auxiliary scanning directions	Display	Description	Setting range	L	Setting the L value	0.0 to 100.0	a	Setting the a value	-200.0 to 200.0	b	Setting the b value	-200.0 to 200.0
Display	Description																																		
N875	Setting the N875 patch for the original for adjustment																																		
N475	Setting the N475 patch for the original for adjustment																																		
N125	Setting the N125 patch for the original for adjustment																																		
CYAN	Setting the cyan patch for the original for adjustment																																		
MAGENTA	Setting the magenta patch for the original for adjustment																																		
YELLOW	Setting the yellow patch for the original for adjustment																																		
RED	Setting the red patch for the original for adjustment																																		
GREEN	Setting the green patch for the original for adjustment																																		
BLUE	Setting the blue patch for the original for adjustment																																		
ADJUST ORIGINAL	Setting the main and auxiliary scanning directions																																		
Display	Description	Setting range																																	
L	Setting the L value	0.0 to 100.0																																	
a	Setting the a value	-200.0 to 200.0																																	
b	Setting the b value	-200.0 to 200.0																																	

Item No.	Description
<p>U425</p>	<p>Setting: [ADJUST ORIGINAL]</p> <ol style="list-style-type: none"> 1. Measure the distance from the left edge to the black belt (a) of the original at A, B and C. Measurement procedure <ol style="list-style-type: none"> 1) Measure the distance from the edge to the black belt (a) of the original at A (30 mm from the leading edge), B (148.5 mm from the leading edge) and C (267 mm from the leading edge), respectively. 2) Apply the following formula for the values obtained: $((A + C) / 2 + B) / 2$ 2. Enter the values solved using the cursor left/right keys or numeric keys in [MAIN]. 3. Press the start key. The value is set. 4. Measure the distance from the leading edge to the black belt (b) of the original at D, E and F. Measurement procedure <ol style="list-style-type: none"> 1) Measure the distance from the edge to the black belt (b) of the original at D (35 mm from the left edge), E (110 mm from the left edge) and F (185 mm from the left edge), respectively. 2) Apply the following formula for the values obtained: $((D + F) / 2 + E) / 2$ 5. Enter the values solved using the cursor left/right keys or numeric keys in [SUB LEAD]. 6. Press the start key. The value is set. 7. Measure the length (G) from the edge of the black belt (b) to edge of the black belt (c) of the original. 8. Enter the measured value using the cursor left/right keys or numeric keys in [SUB TAIL]. 9. Press the start key. The value is set. <div style="border: 1px solid black; padding: 5px; width: fit-content; margin-left: auto; margin-right: auto;"> <p>[MAIN] = $((A + C) / 2 + B) / 2$</p> <p>[SUB LEAD] = $((D + F) / 2 + E) / 2$</p> <p>[SUB TAIL] = G</p> </div> <p style="text-align: center;">Original for adjustment (P/N: 302FZ56990)</p> <p style="text-align: center;">Figure 1-3-2</p> <p>Completion Press the stop key. The screen for selecting a maintenance item No. is displayed.</p>

Item No.	Description																																																																												
U600	<p data-bbox="288 241 523 273">Initializing all data</p> <p data-bbox="288 315 440 347">Description</p> <p data-bbox="288 349 1422 412">Initializes software switches and all data in the backup data on the FAX control PWB, according to the destination and OEM.</p> <p data-bbox="288 418 1426 481">Executes the check of the file system, when abnormality of the file system is detected, initializes the file system, communication past record and register setting contents.</p> <p data-bbox="288 488 400 519">Purpose</p> <p data-bbox="288 521 687 553">To initialize the FAX control PWB.</p> <p data-bbox="288 591 387 622">Method</p> <ol data-bbox="304 627 1433 965" style="list-style-type: none"> 1. Press the start key. 2. Select [Execute]. The screen for entering the destination code and OEM code is displayed. 3. Select [Country Code] and enter a destination code using the numeric keys (refer to the destination code list on following for the destination code). 4. Press the start key. There is no operation necessary on this screen. The destination code and the OEM code are displayed with the values currently set. 5. Press the start key. Data initialization starts. To cancel data initialization, press the stop key. 6. After data initialization, the entered destination, OEM codes and ROM version are displayed. A ROM version displays three kinds, application, boot, and IPL. <p data-bbox="288 1003 555 1034">Destination code list</p> <table border="1" data-bbox="336 1048 1401 1955"> <thead> <tr> <th data-bbox="336 1048 488 1088">Code</th> <th data-bbox="488 1048 871 1088">Destination</th> <th data-bbox="871 1048 1023 1088">Code</th> <th data-bbox="1023 1048 1401 1088">Destination</th> </tr> </thead> <tbody> <tr> <td data-bbox="336 1088 488 1128">000</td> <td data-bbox="488 1088 871 1128">Japan</td> <td data-bbox="871 1088 1023 1128">253</td> <td data-bbox="1023 1088 1401 1128">CTR21 (European nations)</td> </tr> <tr> <td data-bbox="336 1128 488 1169">009</td> <td data-bbox="488 1128 871 1169">Australia</td> <td></td> <td data-bbox="1023 1128 1401 1169">Italy</td> </tr> <tr> <td data-bbox="336 1169 488 1209">038</td> <td data-bbox="488 1169 871 1209">China</td> <td></td> <td data-bbox="1023 1169 1401 1209">Germany</td> </tr> <tr> <td data-bbox="336 1209 488 1249">080</td> <td data-bbox="488 1209 871 1249">Hong Kong</td> <td></td> <td data-bbox="1023 1209 1401 1249">Spain</td> </tr> <tr> <td data-bbox="336 1249 488 1290">084</td> <td data-bbox="488 1249 871 1290">Indonesia</td> <td></td> <td data-bbox="1023 1249 1401 1290">U.K.</td> </tr> <tr> <td data-bbox="336 1290 488 1330">088</td> <td data-bbox="488 1290 871 1330">Israel</td> <td></td> <td data-bbox="1023 1290 1401 1330">Netherlands</td> </tr> <tr> <td data-bbox="336 1330 488 1370">097</td> <td data-bbox="488 1330 871 1370">Korea</td> <td></td> <td data-bbox="1023 1330 1401 1370">Sweden</td> </tr> <tr> <td data-bbox="336 1370 488 1411">108</td> <td data-bbox="488 1370 871 1411">Malaysia</td> <td></td> <td data-bbox="1023 1370 1401 1411">France</td> </tr> <tr> <td data-bbox="336 1411 488 1451">126</td> <td data-bbox="488 1411 871 1451">New Zealand</td> <td></td> <td data-bbox="1023 1411 1401 1451">Austria</td> </tr> <tr> <td data-bbox="336 1451 488 1491">136</td> <td data-bbox="488 1451 871 1491">Peru</td> <td></td> <td data-bbox="1023 1451 1401 1491">Switzerland</td> </tr> <tr> <td data-bbox="336 1491 488 1532">137</td> <td data-bbox="488 1491 871 1532">Philippines</td> <td></td> <td data-bbox="1023 1491 1401 1532">Belgium</td> </tr> <tr> <td data-bbox="336 1532 488 1572">152</td> <td data-bbox="488 1532 871 1572">Middle East</td> <td></td> <td data-bbox="1023 1532 1401 1572">Denmark</td> </tr> <tr> <td data-bbox="336 1572 488 1612">156</td> <td data-bbox="488 1572 871 1612">Singapore</td> <td></td> <td data-bbox="1023 1572 1401 1612">Finland</td> </tr> <tr> <td data-bbox="336 1612 488 1653">159</td> <td data-bbox="488 1612 871 1653">South Africa</td> <td></td> <td data-bbox="1023 1612 1401 1653">Portugal</td> </tr> <tr> <td data-bbox="336 1653 488 1693">169</td> <td data-bbox="488 1653 871 1693">Thailand</td> <td></td> <td data-bbox="1023 1653 1401 1693">Ireland</td> </tr> <tr> <td data-bbox="336 1693 488 1733">181</td> <td data-bbox="488 1693 871 1733">U.S.A.</td> <td></td> <td data-bbox="1023 1693 1401 1733">Norway</td> </tr> <tr> <td data-bbox="336 1733 488 1774">242</td> <td data-bbox="488 1733 871 1774">South America</td> <td data-bbox="871 1733 1023 1774">254</td> <td data-bbox="1023 1733 1401 1774">Taiwan</td> </tr> <tr> <td data-bbox="336 1774 488 1814">243</td> <td data-bbox="488 1774 871 1814">Saudi Arabia</td> <td></td> <td></td> </tr> </tbody> </table>	Code	Destination	Code	Destination	000	Japan	253	CTR21 (European nations)	009	Australia		Italy	038	China		Germany	080	Hong Kong		Spain	084	Indonesia		U.K.	088	Israel		Netherlands	097	Korea		Sweden	108	Malaysia		France	126	New Zealand		Austria	136	Peru		Switzerland	137	Philippines		Belgium	152	Middle East		Denmark	156	Singapore		Finland	159	South Africa		Portugal	169	Thailand		Ireland	181	U.S.A.		Norway	242	South America	254	Taiwan	243	Saudi Arabia		
Code	Destination	Code	Destination																																																																										
000	Japan	253	CTR21 (European nations)																																																																										
009	Australia		Italy																																																																										
038	China		Germany																																																																										
080	Hong Kong		Spain																																																																										
084	Indonesia		U.K.																																																																										
088	Israel		Netherlands																																																																										
097	Korea		Sweden																																																																										
108	Malaysia		France																																																																										
126	New Zealand		Austria																																																																										
136	Peru		Switzerland																																																																										
137	Philippines		Belgium																																																																										
152	Middle East		Denmark																																																																										
156	Singapore		Finland																																																																										
159	South Africa		Portugal																																																																										
169	Thailand		Ireland																																																																										
181	U.S.A.		Norway																																																																										
242	South America	254	Taiwan																																																																										
243	Saudi Arabia																																																																												

Item No.	Description								
U601	<p>Initializing permanent data</p> <p>Description Initializes software switches on the FAX control PWB according to the destination and OEM.</p> <p>Purpose To initialize the FAX control PWB without changing user registration data.</p> <p>Method</p> <ol style="list-style-type: none"> 1. Press the start key. 2. Select [Execute]. The screen for entering the destination code and OEM code is displayed. 3. Select [Country Code] and enter a destination code using the numeric keys (refer to the destination code list on page 1-3-22 for the destination code). 4. Press the start key. There is no operation necessary on this screen. The destination code and the OEM code are displayed with the values currently set. 5. Press the start key. Data initialization starts. To cancel data initialization, press the back key. 6. After data initialization, the entered destination, OEM codes and ROM version are displayed. A ROM version displays three kinds, application, boot, and IPL. 								
U603	<p>Setting user data 1</p> <p>Description Makes user settings to enable the use of the machine as a fax.</p> <p>Purpose To be run after installation of the facsimile kit if necessary.</p> <p>Method</p> <ol style="list-style-type: none"> 1. Press the start key. 2. Select [LINE TYPE] and press the start key. 3. Select the setting using the cursor up/down keys. <table border="1" data-bbox="335 1299 1401 1496"> <thead> <tr> <th data-bbox="335 1299 638 1355">Display</th> <th data-bbox="638 1299 1401 1355">Description</th> </tr> </thead> <tbody> <tr> <td data-bbox="335 1355 638 1400">DTMF</td> <td data-bbox="638 1355 1401 1400">DTMF</td> </tr> <tr> <td data-bbox="335 1400 638 1444">10PPS</td> <td data-bbox="638 1400 1401 1444">10 PPS</td> </tr> <tr> <td data-bbox="335 1444 638 1496">20PPS</td> <td data-bbox="638 1444 1401 1496">20 PPS</td> </tr> </tbody> </table> <p>* : Initial setting: DTMF</p> <ol style="list-style-type: none"> 4. Press the start key. The setting is set. <p>Completion Press the stop key. The screen for selecting a maintenance item No. is displayed.</p>	Display	Description	DTMF	DTMF	10PPS	10 PPS	20PPS	20 PPS
Display	Description								
DTMF	DTMF								
10PPS	10 PPS								
20PPS	20 PPS								

Item No.	Description						
U604	<p>Setting user data 2</p> <p>Description Makes user settings to enable the use of the machine as a fax.</p> <p>Purpose Use this if the user wishes to adjust the number of rings that occur before the unit switches into fax receiving mode when fax/telephone auto-select is enabled.</p> <p>Method</p> <ol style="list-style-type: none"> 1. Press the start key. 2. Select [RINGS(F/P)#]. 3. Change the setting using the cursor left/right keys or numeric keys. <table border="1" data-bbox="336 667 1401 763"> <thead> <tr> <th data-bbox="336 667 868 712">Description</th> <th data-bbox="868 667 1098 712">Setting range</th> <th data-bbox="1098 667 1401 712">Initial setting</th> </tr> </thead> <tbody> <tr> <td data-bbox="336 712 868 763">Number of fax/telephone rings</td> <td data-bbox="868 712 1098 763">0 to 15</td> <td data-bbox="1098 712 1401 763">2 (120 V)/1 (220-240 V)</td> </tr> </tbody> </table> <p>* : If you set this to 0, the unit will start fax reception without any ringing.</p> <ol style="list-style-type: none"> 4. Press the start key. The value is set. <p>Completion Press the stop key. The screen for selecting a maintenance item No. is displayed.</p>	Description	Setting range	Initial setting	Number of fax/telephone rings	0 to 15	2 (120 V)/1 (220-240 V)
Description	Setting range	Initial setting					
Number of fax/telephone rings	0 to 15	2 (120 V)/1 (220-240 V)					
U605	<p>Clearing data</p> <p>Description Initializes data related to the fax transmission such as transmission history.</p> <p>Purpose To clear the transmission history.</p> <p>Method</p> <ol style="list-style-type: none"> 1. Press the start key. 2. Select [CLEAR COM.REC.]. 3. Press the start key. Initialization processing starts. When processing is finished, [Completed] is displayed. <p>Completion Press the stop key. The screen for selecting a maintenance item No. is displayed.</p>						

Item No.	Description																								
U610	<p data-bbox="288 241 502 275">Setting system 1</p> <p data-bbox="288 315 438 342">Description</p> <p data-bbox="288 347 1404 414">Makes settings for fax reception regarding the sizes of the fax paper and received images and automatic printing of the protocol list.</p> <p data-bbox="288 450 391 477">Method</p> <ol data-bbox="304 488 997 548" style="list-style-type: none"> 1. Press the start key. 2. Select the item to be set using the cursor up/down keys. <table border="1" data-bbox="336 562 1401 857"> <thead> <tr> <th data-bbox="336 562 639 607">Display</th> <th data-bbox="639 562 1401 607">Description</th> </tr> </thead> <tbody> <tr> <td data-bbox="336 607 639 689">CUT LINE:100%</td> <td data-bbox="639 607 1401 689">Sets the number of lines to be ignored when receiving a fax at 100% magnification.</td> </tr> <tr> <td data-bbox="336 689 639 772">CUT LINE:AUTO</td> <td data-bbox="639 689 1401 772">Sets the number of lines to be ignored when receiving a fax in the auto reduction mode.</td> </tr> <tr> <td data-bbox="336 772 639 857">CUT LINE:A4</td> <td data-bbox="639 772 1401 857">Sets the number of lines to be ignored when receiving a fax (A4R/LetterR) in the auto reduction mode.</td> </tr> </tbody> </table> <p data-bbox="288 907 1372 936">Setting the number of lines to be ignored when receiving a fax at 100% magnification</p> <p data-bbox="288 940 1433 1041">Sets the maximum number of lines to be ignored if the received data volume exceeds the recording capacity when recording the data at 100% magnification. If the number of excess lines is below the setting, those lines are ignored. If over the setting, they are recorded on the next page.</p> <ol data-bbox="304 1046 1125 1075" style="list-style-type: none"> 1. Change the setting using the cursor left/right keys or numeric keys. <table border="1" data-bbox="336 1088 1401 1249"> <thead> <tr> <th data-bbox="336 1088 823 1171">Description</th> <th data-bbox="823 1088 1007 1171">Setting range</th> <th data-bbox="1007 1088 1190 1171">Initial setting</th> <th data-bbox="1190 1088 1401 1171">Change in value per step</th> </tr> </thead> <tbody> <tr> <td data-bbox="336 1171 823 1249">Number of lines to be ignored when receiving at 100%</td> <td data-bbox="823 1171 1007 1249">0 to 22</td> <td data-bbox="1007 1171 1190 1249">3</td> <td data-bbox="1190 1171 1401 1249">16 lines</td> </tr> </tbody> </table> <p data-bbox="336 1261 1364 1328">* : Increase the setting if a blank second page is output, and decrease it if the received image does not include the entire transmitted data.</p> <ol data-bbox="304 1332 766 1361" style="list-style-type: none"> 2. Press the start key. The value is set. <p data-bbox="288 1400 1433 1429">Setting the number of lines to be ignored when receiving a fax in the auto reduction mode</p> <p data-bbox="288 1433 1433 1568">Sets the maximum number of lines to be ignored if the received data volume exceeds the recording capacity when the data is recorded in the auto reduction mode. If the number of excess lines is below the setting, those lines are ignored. If over the setting, the entire data on a page is further reduced so that it can be recorded on the same page.</p> <ol data-bbox="304 1572 1125 1601" style="list-style-type: none"> 1. Change the setting using the cursor left/right keys or numeric keys. <table border="1" data-bbox="336 1615 1401 1776"> <thead> <tr> <th data-bbox="336 1615 823 1697">Description</th> <th data-bbox="823 1615 1007 1697">Setting range</th> <th data-bbox="1007 1615 1190 1697">Initial setting</th> <th data-bbox="1190 1615 1401 1697">Change in value per step</th> </tr> </thead> <tbody> <tr> <td data-bbox="336 1697 823 1776">Number of lines to be ignored when receiving in the auto reduction mode</td> <td data-bbox="823 1697 1007 1776">0 to 22</td> <td data-bbox="1007 1697 1190 1776">0</td> <td data-bbox="1190 1697 1401 1776">16 lines</td> </tr> </tbody> </table> <p data-bbox="336 1787 1396 1888">* : Increase the setting if a page received in the reduction mode is over-reduced and too much trailing edge margin is left. Decrease it if the received image does not include all transmitted data.</p> <ol data-bbox="304 1892 766 1921" style="list-style-type: none"> 2. Press the start key. The value is set. 	Display	Description	CUT LINE:100%	Sets the number of lines to be ignored when receiving a fax at 100% magnification.	CUT LINE:AUTO	Sets the number of lines to be ignored when receiving a fax in the auto reduction mode.	CUT LINE:A4	Sets the number of lines to be ignored when receiving a fax (A4R/LetterR) in the auto reduction mode.	Description	Setting range	Initial setting	Change in value per step	Number of lines to be ignored when receiving at 100%	0 to 22	3	16 lines	Description	Setting range	Initial setting	Change in value per step	Number of lines to be ignored when receiving in the auto reduction mode	0 to 22	0	16 lines
Display	Description																								
CUT LINE:100%	Sets the number of lines to be ignored when receiving a fax at 100% magnification.																								
CUT LINE:AUTO	Sets the number of lines to be ignored when receiving a fax in the auto reduction mode.																								
CUT LINE:A4	Sets the number of lines to be ignored when receiving a fax (A4R/LetterR) in the auto reduction mode.																								
Description	Setting range	Initial setting	Change in value per step																						
Number of lines to be ignored when receiving at 100%	0 to 22	3	16 lines																						
Description	Setting range	Initial setting	Change in value per step																						
Number of lines to be ignored when receiving in the auto reduction mode	0 to 22	0	16 lines																						

Item No.	Description								
U610	<p data-bbox="287 241 1412 309">Setting the number of lines to be ignored when receiving a fax (A4R/LetterR) in the auto reduction mode</p> <p data-bbox="287 313 1428 414">Sets the maximum number of lines to be ignored if the received data volume exceeds the recording capacity when the data is recorded in the auto reduction mode onto A4R or LetterR paper under the conditions below.</p> <p data-bbox="287 418 1428 486">If the number of excess lines is below the setting, those lines are ignored. If over the setting, the entire data on a page is further reduced so that it can be recorded on the same page.</p> <p data-bbox="303 490 1125 519">1. Change the setting using the cursor left/right keys or numeric keys.</p> <table border="1" data-bbox="335 526 1396 728"> <thead> <tr> <th data-bbox="343 533 821 611">Description</th> <th data-bbox="821 533 1005 611">Setting range</th> <th data-bbox="1005 533 1189 611">Initial setting</th> <th data-bbox="1189 533 1388 611">Change in value per step</th> </tr> </thead> <tbody> <tr> <td data-bbox="343 611 821 721">Number of lines to be ignored when receiving a fax (A4R, letter) in the auto reduction mode</td> <td data-bbox="821 611 1005 721">0 to 22</td> <td data-bbox="1005 611 1189 721">0</td> <td data-bbox="1189 611 1388 721">16 lines</td> </tr> </tbody> </table> <p data-bbox="335 739 1396 840">* : Increase the setting if a page received in the reduction mode is over-reduced and too much trailing edge margin is left. Decrease it if the received image does not include all transmitted data.</p> <p data-bbox="303 844 766 873">2. Press the start key. The value is set.</p> <p data-bbox="287 913 438 943">Completion</p> <p data-bbox="287 947 1252 976">Press the stop key. The screen for selecting a maintenance item No. is displayed.</p>	Description	Setting range	Initial setting	Change in value per step	Number of lines to be ignored when receiving a fax (A4R, letter) in the auto reduction mode	0 to 22	0	16 lines
Description	Setting range	Initial setting	Change in value per step						
Number of lines to be ignored when receiving a fax (A4R, letter) in the auto reduction mode	0 to 22	0	16 lines						

Item No.	Description																										
U611	<p data-bbox="287 241 507 275">Setting system 2</p> <p data-bbox="287 313 440 342">Description Sets the number of adjustment lines for automatic reduction.</p> <p data-bbox="287 416 387 445">Method</p> <ol data-bbox="304 450 1002 517" style="list-style-type: none"> 1. Press the start key. 2. Select the item to be set using the cursor up/down keys. <table border="1" data-bbox="336 528 1401 790"> <thead> <tr> <th data-bbox="336 528 639 573">Display</th> <th data-bbox="639 528 1401 573">Description</th> </tr> </thead> <tbody> <tr> <td data-bbox="336 573 639 618">ADJ LINES</td> <td data-bbox="639 573 1401 618">Sets the number of adjustment lines for automatic reduction.</td> </tr> <tr> <td data-bbox="336 618 639 696">ADJ LINES(A4)</td> <td data-bbox="639 618 1401 696">Sets the number of adjustment lines for automatic reduction when A4 paper is set.</td> </tr> <tr> <td data-bbox="336 696 639 790">ADJ LINES(LT)</td> <td data-bbox="639 696 1401 790">Sets the number of adjustment lines for automatic reduction when letter size paper is set.</td> </tr> </tbody> </table> <p data-bbox="287 831 1094 860">Setting the number of adjustment lines for automatic reduction Sets the number of adjustment lines for automatic reduction.</p> <ol data-bbox="304 898 1129 927" style="list-style-type: none"> 1. Change the setting using the cursor left/right keys or numeric keys. <table border="1" data-bbox="336 943 1401 1039"> <thead> <tr> <th data-bbox="336 943 975 987">Description</th> <th data-bbox="975 943 1187 987">Setting range</th> <th data-bbox="1187 943 1401 987">Initial setting</th> </tr> </thead> <tbody> <tr> <td data-bbox="336 987 975 1039">Number of adjustment lines for automatic reduction</td> <td data-bbox="975 987 1187 1039">0 to 22</td> <td data-bbox="1187 987 1401 1039">7</td> </tr> </tbody> </table> <ol data-bbox="304 1055 767 1084" style="list-style-type: none"> 2. Press the start key. The value is set. <p data-bbox="287 1122 1369 1151">Setting the number of adjustment lines for automatic reduction when A4 paper is set Sets the number of adjustment lines for automatic reduction when A4 paper is set.</p> <ol data-bbox="304 1189 1129 1218" style="list-style-type: none"> 1. Change the setting using the cursor left/right keys or numeric keys. <table border="1" data-bbox="336 1234 1401 1361"> <thead> <tr> <th data-bbox="336 1234 975 1279">Description</th> <th data-bbox="975 1234 1187 1279">Setting range</th> <th data-bbox="1187 1234 1401 1279">Initial setting</th> </tr> </thead> <tbody> <tr> <td data-bbox="336 1279 975 1361">Number of adjustment lines for automatic reduction when A4 paper is set</td> <td data-bbox="975 1279 1187 1361">0 to 22</td> <td data-bbox="1187 1279 1401 1361">22</td> </tr> </tbody> </table> <ol data-bbox="304 1377 767 1406" style="list-style-type: none"> 2. Press the start key. The value is set. <p data-bbox="287 1444 1410 1505">Setting the number of adjustment lines for automatic reduction when letter size paper is set Sets the number of adjustment lines for automatic reduction when letter size paper is set.</p> <ol data-bbox="304 1547 1129 1576" style="list-style-type: none"> 1. Change the setting using the cursor left/right keys or numeric keys. <table border="1" data-bbox="336 1592 1401 1720"> <thead> <tr> <th data-bbox="336 1592 975 1637">Description</th> <th data-bbox="975 1592 1187 1637">Setting range</th> <th data-bbox="1187 1592 1401 1637">Initial setting</th> </tr> </thead> <tbody> <tr> <td data-bbox="336 1637 975 1720">Number of adjustment lines for automatic reduction when letter size paper is set</td> <td data-bbox="975 1637 1187 1720">0 to 26</td> <td data-bbox="1187 1637 1401 1720">26</td> </tr> </tbody> </table> <ol data-bbox="304 1736 767 1765" style="list-style-type: none"> 2. Press the start key. The value is set. <p data-bbox="287 1803 440 1832">Completion Press the stop key. The screen for selecting a maintenance item No. is displayed.</p>	Display	Description	ADJ LINES	Sets the number of adjustment lines for automatic reduction.	ADJ LINES(A4)	Sets the number of adjustment lines for automatic reduction when A4 paper is set.	ADJ LINES(LT)	Sets the number of adjustment lines for automatic reduction when letter size paper is set.	Description	Setting range	Initial setting	Number of adjustment lines for automatic reduction	0 to 22	7	Description	Setting range	Initial setting	Number of adjustment lines for automatic reduction when A4 paper is set	0 to 22	22	Description	Setting range	Initial setting	Number of adjustment lines for automatic reduction when letter size paper is set	0 to 26	26
Display	Description																										
ADJ LINES	Sets the number of adjustment lines for automatic reduction.																										
ADJ LINES(A4)	Sets the number of adjustment lines for automatic reduction when A4 paper is set.																										
ADJ LINES(LT)	Sets the number of adjustment lines for automatic reduction when letter size paper is set.																										
Description	Setting range	Initial setting																									
Number of adjustment lines for automatic reduction	0 to 22	7																									
Description	Setting range	Initial setting																									
Number of adjustment lines for automatic reduction when A4 paper is set	0 to 22	22																									
Description	Setting range	Initial setting																									
Number of adjustment lines for automatic reduction when letter size paper is set	0 to 26	26																									

Item No.	Description																						
U612	<p data-bbox="287 241 507 275">Setting system 3</p> <p data-bbox="287 313 438 342">Description Makes settings for fax transmission regarding operation and automatic printing of the protocol list.</p> <p data-bbox="287 450 387 479">Method</p> <ol data-bbox="304 488 1002 551" style="list-style-type: none"> 1. Press the start key. 2. Select the item to be set using the cursor up/down keys. <table border="1" data-bbox="336 562 1401 790"> <thead> <tr> <th data-bbox="336 562 639 607">Display</th> <th data-bbox="639 562 1401 607">Description</th> </tr> </thead> <tbody> <tr> <td data-bbox="336 607 639 689">AUTO REDUCTION</td> <td data-bbox="639 607 1401 689">Selects if auto reduction in the auxiliary direction is to be performed.</td> </tr> <tr> <td data-bbox="336 689 639 734">PROTOCOL LIST</td> <td data-bbox="639 689 1401 734">Sets the automatic printing of the protocol list.</td> </tr> <tr> <td data-bbox="336 734 639 790">DETECT TRAIL</td> <td data-bbox="639 734 1401 790">Sets the detection of trailing edge margin.</td> </tr> </tbody> </table> <p data-bbox="287 837 1185 869">Selecting if auto reduction in the auxiliary direction is to be performed</p> <p data-bbox="287 873 1428 936">Sets whether to receive a long document by automatically reducing it in the auxiliary direction or at 100% magnification.</p> <ol data-bbox="304 943 911 974" style="list-style-type: none"> 1. Select the setting using the cursor left/right keys. <table border="1" data-bbox="336 985 1401 1167"> <thead> <tr> <th data-bbox="336 985 639 1030">Display</th> <th data-bbox="639 985 1401 1030">Description</th> </tr> </thead> <tbody> <tr> <td data-bbox="336 1030 639 1113">ON</td> <td data-bbox="639 1030 1401 1113">Auto reduction is performed if the received document is longer than the fax paper.</td> </tr> <tr> <td data-bbox="336 1113 639 1167">OFF</td> <td data-bbox="639 1113 1401 1167">Auto reduction is not performed.</td> </tr> </tbody> </table> <p data-bbox="331 1173 579 1205">* : Initial setting: ON</p> <ol data-bbox="304 1211 783 1243" style="list-style-type: none"> 2. Press the start key. The setting is set. <p data-bbox="287 1279 914 1310">Setting the automatic printing of the protocol list</p> <p data-bbox="287 1314 887 1346">Sets if the protocol list is automatically printed out.</p> <ol data-bbox="304 1350 911 1382" style="list-style-type: none"> 1. Select the setting using the cursor left/right keys. <table border="1" data-bbox="336 1393 1401 1653"> <thead> <tr> <th data-bbox="336 1393 639 1438">Display</th> <th data-bbox="639 1393 1401 1438">Description</th> </tr> </thead> <tbody> <tr> <td data-bbox="336 1438 639 1520">ON</td> <td data-bbox="639 1438 1401 1520">The protocol list is automatically printed out after communication.</td> </tr> <tr> <td data-bbox="336 1520 639 1565">OFF</td> <td data-bbox="639 1520 1401 1565">The protocol list is not printed out automatically.</td> </tr> <tr> <td data-bbox="336 1565 639 1653">ERR</td> <td data-bbox="639 1565 1401 1653">The protocol list is automatically printed out after communication only if a communication error occurs.</td> </tr> </tbody> </table> <p data-bbox="331 1659 595 1691">* : Initial setting: OFF</p> <ol data-bbox="304 1697 783 1729" style="list-style-type: none"> 2. Press the start key. The setting is set. 	Display	Description	AUTO REDUCTION	Selects if auto reduction in the auxiliary direction is to be performed.	PROTOCOL LIST	Sets the automatic printing of the protocol list.	DETECT TRAIL	Sets the detection of trailing edge margin.	Display	Description	ON	Auto reduction is performed if the received document is longer than the fax paper.	OFF	Auto reduction is not performed.	Display	Description	ON	The protocol list is automatically printed out after communication.	OFF	The protocol list is not printed out automatically.	ERR	The protocol list is automatically printed out after communication only if a communication error occurs.
Display	Description																						
AUTO REDUCTION	Selects if auto reduction in the auxiliary direction is to be performed.																						
PROTOCOL LIST	Sets the automatic printing of the protocol list.																						
DETECT TRAIL	Sets the detection of trailing edge margin.																						
Display	Description																						
ON	Auto reduction is performed if the received document is longer than the fax paper.																						
OFF	Auto reduction is not performed.																						
Display	Description																						
ON	The protocol list is automatically printed out after communication.																						
OFF	The protocol list is not printed out automatically.																						
ERR	The protocol list is automatically printed out after communication only if a communication error occurs.																						

Item No.	Description						
U612	<p>Selecting if detection of trail edge margin is to be performed This determines whether trailing edge margin is detected (to prevent image from being mutilated) while printing a received Fax.</p> <p>1. Select the setting using the cursor left/right keys.</p> <table border="1" data-bbox="335 425 1404 571"> <thead> <tr> <th data-bbox="335 425 638 470">Display</th> <th data-bbox="638 425 1404 470">Description</th> </tr> </thead> <tbody> <tr> <td data-bbox="335 470 638 515">ON</td> <td data-bbox="638 470 1404 515">The trail edge margin is detected.</td> </tr> <tr> <td data-bbox="335 515 638 571">OFF</td> <td data-bbox="638 515 1404 571">The trail edge margin is not detected.</td> </tr> </tbody> </table> <p>* : Initial setting: ON</p> <p>2. Press the start key. The setting is set.</p> <p>Completion Press the stop key. The screen for selecting a maintenance item No. is displayed.</p>	Display	Description	ON	The trail edge margin is detected.	OFF	The trail edge margin is not detected.
Display	Description						
ON	The trail edge margin is detected.						
OFF	The trail edge margin is not detected.						
U620	<p>Setting the remote switching mode</p> <p>Description Sets the signal detection method for remote switching. Be sure to change the setting according to the type of telephone connected to the machine.</p> <p>Setting</p> <p>1. Press the start key. 2. Select [REMORT MODE] and press the start key. 3. Select the mode using the cursor up/down keys.</p> <table border="1" data-bbox="335 1187 1404 1332"> <thead> <tr> <th data-bbox="335 1187 638 1232">Display</th> <th data-bbox="638 1187 1404 1232">Description</th> </tr> </thead> <tbody> <tr> <td data-bbox="335 1232 638 1276">ONE</td> <td data-bbox="638 1232 1404 1276">One-shot detection</td> </tr> <tr> <td data-bbox="335 1276 638 1332">CONT</td> <td data-bbox="638 1276 1404 1332">Continuous detection</td> </tr> </tbody> </table> <p>* : Initial setting: ONE</p> <p>4. Press the start key. The setting is set.</p> <p>Completion Press the stop key. The screen for selecting a maintenance item No. is displayed.</p>	Display	Description	ONE	One-shot detection	CONT	Continuous detection
Display	Description						
ONE	One-shot detection						
CONT	Continuous detection						

Item No.	Description												
U625	<p>Setting the transmission system 1</p> <p>Description Makes settings for the auto redialing interval and the number of times of auto redialing.</p> <p>Purpose Change the setting to prevent the following problems: fax transmission is not possible due to too short redial interval, or fax transmission takes too much time to complete due to too long redial interval.</p> <p>Method</p> <ol style="list-style-type: none"> 1. Press the start key. 2. Select the item to be set using the cursor up/down keys. <table border="1" data-bbox="335 667 1401 810"> <thead> <tr> <th>Display</th> <th>Description</th> </tr> </thead> <tbody> <tr> <td>INTERVAL</td> <td>Setting the auto redialing interval</td> </tr> <tr> <td>TIMES</td> <td>Setting the number of times of auto redialing</td> </tr> </tbody> </table> <p>Setting the auto redialing interval</p> <ol style="list-style-type: none"> 1. Change the setting using the cursor left/right keys. <table border="1" data-bbox="335 929 1401 1025"> <thead> <tr> <th>Description</th> <th>Setting range</th> <th>Initial setting</th> </tr> </thead> <tbody> <tr> <td>Redialing interval</td> <td>1 to 9 (min.)</td> <td>3 (120 V)/2 (220-240 V)</td> </tr> </tbody> </table> <ol style="list-style-type: none"> 2. Press the start key. The value is set. 	Display	Description	INTERVAL	Setting the auto redialing interval	TIMES	Setting the number of times of auto redialing	Description	Setting range	Initial setting	Redialing interval	1 to 9 (min.)	3 (120 V)/2 (220-240 V)
Display	Description												
INTERVAL	Setting the auto redialing interval												
TIMES	Setting the number of times of auto redialing												
Description	Setting range	Initial setting											
Redialing interval	1 to 9 (min.)	3 (120 V)/2 (220-240 V)											
U625	<p>Setting the number of times of auto redialing</p> <ol style="list-style-type: none"> 1. Change the setting using the cursor left/right keys or numeric keys. <table border="1" data-bbox="335 1400 1401 1496"> <thead> <tr> <th>Description</th> <th>Setting range</th> <th>Initial setting</th> </tr> </thead> <tbody> <tr> <td>Number of redialing</td> <td>0 to 15</td> <td>2 (120 V)/3 (220-240 V)</td> </tr> </tbody> </table> <ol style="list-style-type: none"> 2. Press the start key. The value is set. <p>Completion Press the stop key. The screen for selecting a maintenance item No. is displayed.</p>	Description	Setting range	Initial setting	Number of redialing	0 to 15	2 (120 V)/3 (220-240 V)						
Description	Setting range	Initial setting											
Number of redialing	0 to 15	2 (120 V)/3 (220-240 V)											

Item No.	Description																				
U630	<p data-bbox="287 241 710 275">Setting communication control 1</p> <p data-bbox="287 313 438 342">Description</p> <p data-bbox="287 347 1069 376">Makes settings for fax transmission regarding the communication.</p> <p data-bbox="287 414 391 443">Method</p> <ol data-bbox="303 448 997 515" style="list-style-type: none"> 1. Press the start key. 2. Select the item to be set using the cursor up/down keys. <table border="1" data-bbox="335 526 1404 840"> <thead> <tr> <th data-bbox="343 533 638 577">Display</th> <th data-bbox="638 533 1396 577">Description</th> </tr> </thead> <tbody> <tr> <td data-bbox="343 577 638 622">TX SPEED</td> <td data-bbox="638 577 1396 622">Sets the communication starting speed.</td> </tr> <tr> <td data-bbox="343 622 638 667">RX SPEED</td> <td data-bbox="638 622 1396 667">Sets the reception speed.</td> </tr> <tr> <td data-bbox="343 667 638 757">TX ECHO</td> <td data-bbox="638 667 1396 757">Sets the waiting period to prevent echo problems at the sender.</td> </tr> <tr> <td data-bbox="343 757 638 835">RX ECHO</td> <td data-bbox="638 757 1396 835">Sets the waiting period to prevent echo problems at the receiver.</td> </tr> </tbody> </table> <p data-bbox="287 884 821 913">Setting the communication starting speed</p> <p data-bbox="287 918 1420 981">Sets the initial communication speed when starting transmission. When the destination unit has V.34 capability, V.34 is selected for transmission, regardless of this setting.</p> <ol data-bbox="303 985 917 1019" style="list-style-type: none"> 1. Select the setting using the cursor up/down keys. <table border="1" data-bbox="335 1030 1404 1265"> <thead> <tr> <th data-bbox="343 1037 638 1081">Display</th> <th data-bbox="638 1037 1396 1081">Description</th> </tr> </thead> <tbody> <tr> <td data-bbox="343 1081 638 1126">14400bps/V17</td> <td data-bbox="638 1081 1396 1126">V.17, 14400 bps</td> </tr> <tr> <td data-bbox="343 1126 638 1171">9600bps/V29</td> <td data-bbox="638 1126 1396 1171">V.17, 9600 bps</td> </tr> <tr> <td data-bbox="343 1171 638 1216">4800bps/V27ter</td> <td data-bbox="638 1171 1396 1216">V.27ter, 4800 bps</td> </tr> <tr> <td data-bbox="343 1216 638 1261">2400bps/V27ter</td> <td data-bbox="638 1216 1396 1261">V.27ter, 2400 bps</td> </tr> </tbody> </table> <p data-bbox="335 1276 710 1305">* : Initial setting: 14400bps/V17</p> <ol data-bbox="303 1310 782 1344" style="list-style-type: none"> 2. Press the start key. The setting is set. 	Display	Description	TX SPEED	Sets the communication starting speed.	RX SPEED	Sets the reception speed.	TX ECHO	Sets the waiting period to prevent echo problems at the sender.	RX ECHO	Sets the waiting period to prevent echo problems at the receiver.	Display	Description	14400bps/V17	V.17, 14400 bps	9600bps/V29	V.17, 9600 bps	4800bps/V27ter	V.27ter, 4800 bps	2400bps/V27ter	V.27ter, 2400 bps
Display	Description																				
TX SPEED	Sets the communication starting speed.																				
RX SPEED	Sets the reception speed.																				
TX ECHO	Sets the waiting period to prevent echo problems at the sender.																				
RX ECHO	Sets the waiting period to prevent echo problems at the receiver.																				
Display	Description																				
14400bps/V17	V.17, 14400 bps																				
9600bps/V29	V.17, 9600 bps																				
4800bps/V27ter	V.27ter, 4800 bps																				
2400bps/V27ter	V.27ter, 2400 bps																				

Item No.	Description																						
U630 (cont.)	<p data-bbox="287 241 646 275">Setting the reception speed</p> <p data-bbox="287 277 1412 342">Sets the reception speed that the sender is informed of using the DIS or NSF signal. When the destination unit has V.34 capability, V.34 is selected, regardless of the setting.</p> <p data-bbox="303 344 917 378">1. Select the setting using the cursor up/down keys.</p> <table border="1" data-bbox="335 389 1401 629"> <thead> <tr> <th data-bbox="343 398 638 432">Display</th> <th data-bbox="638 398 1393 432">Description</th> </tr> </thead> <tbody> <tr> <td data-bbox="343 443 638 477">14400bps</td> <td data-bbox="638 443 1393 477">V.17, V.33, V.29, V.27ter</td> </tr> <tr> <td data-bbox="343 488 638 521">9600bps</td> <td data-bbox="638 488 1393 521">V.29, V.27ter</td> </tr> <tr> <td data-bbox="343 533 638 566">4800bps</td> <td data-bbox="638 533 1393 566">V.27ter</td> </tr> <tr> <td data-bbox="343 577 638 611">2400bps</td> <td data-bbox="638 577 1393 611">V.27ter (fallback only)</td> </tr> </tbody> </table> <p data-bbox="335 640 662 674">* : Initial setting: 14400bps</p> <p data-bbox="303 676 782 710">2. Press the start key. The setting is set.</p> <p data-bbox="287 743 1125 777">Setting the waiting period to prevent echo problems at the sender</p> <p data-bbox="287 779 1420 844">Sets the period before a DCS signal is sent after a DIS signal is received. Used when problems occur due to echoes at the sender.</p> <p data-bbox="303 846 917 880">1. Select the setting using the cursor up/down keys.</p> <table border="1" data-bbox="335 891 1401 1032"> <thead> <tr> <th data-bbox="343 900 638 934">Display</th> <th data-bbox="638 900 1393 934">Description</th> </tr> </thead> <tbody> <tr> <td data-bbox="343 945 638 978">500</td> <td data-bbox="638 945 1393 978">Sends a DCS 500 ms after receiving a DIS.</td> </tr> <tr> <td data-bbox="343 990 638 1023">300</td> <td data-bbox="638 990 1393 1023">Sends a DCS 300 ms after receiving a DIS.</td> </tr> </tbody> </table> <p data-bbox="335 1039 582 1072">* : Initial setting: 300</p> <p data-bbox="303 1075 782 1108">2. Press the start key. The setting is set.</p> <p data-bbox="287 1142 1141 1176">Setting the waiting period to prevent echo problems at the receiver</p> <p data-bbox="287 1178 1396 1243">Sets the period before an NSF, CSI or DIS signal is sent after a CED signal is received. Used when problems occur due to echoes at the receiver.</p> <p data-bbox="303 1245 917 1279">1. Select the setting using the cursor up/down keys.</p> <table border="1" data-bbox="335 1290 1401 1435"> <thead> <tr> <th data-bbox="343 1299 638 1332">Display</th> <th data-bbox="638 1299 1393 1332">Description</th> </tr> </thead> <tbody> <tr> <td data-bbox="343 1344 638 1377">500</td> <td data-bbox="638 1344 1393 1377">Sends an NSF, CSI or DIS 500 ms after receiving a CED.</td> </tr> <tr> <td data-bbox="343 1388 638 1422">75</td> <td data-bbox="638 1388 1393 1422">Sends an NSF, CSI or DIS 75 ms after receiving a CED.</td> </tr> </tbody> </table> <p data-bbox="335 1442 566 1476">* : Initial setting: 75</p> <p data-bbox="303 1478 782 1512">2. Press the start key. The setting is set.</p> <p data-bbox="287 1545 438 1579">Completion</p> <p data-bbox="287 1581 1252 1615">Press the stop key. The screen for selecting a maintenance item No. is displayed.</p>	Display	Description	14400bps	V.17, V.33, V.29, V.27ter	9600bps	V.29, V.27ter	4800bps	V.27ter	2400bps	V.27ter (fallback only)	Display	Description	500	Sends a DCS 500 ms after receiving a DIS.	300	Sends a DCS 300 ms after receiving a DIS.	Display	Description	500	Sends an NSF, CSI or DIS 500 ms after receiving a CED.	75	Sends an NSF, CSI or DIS 75 ms after receiving a CED.
Display	Description																						
14400bps	V.17, V.33, V.29, V.27ter																						
9600bps	V.29, V.27ter																						
4800bps	V.27ter																						
2400bps	V.27ter (fallback only)																						
Display	Description																						
500	Sends a DCS 500 ms after receiving a DIS.																						
300	Sends a DCS 300 ms after receiving a DIS.																						
Display	Description																						
500	Sends an NSF, CSI or DIS 500 ms after receiving a CED.																						
75	Sends an NSF, CSI or DIS 75 ms after receiving a CED.																						

Item No.	Description																										
U631	<p data-bbox="288 241 710 275">Setting communication control 2</p> <p data-bbox="288 313 438 342">Description Makes settings regarding fax transmission.</p> <p data-bbox="288 416 387 445">Method</p> <ol data-bbox="304 452 1002 517" style="list-style-type: none"> 1. Press the start key. 2. Select the item to be set using the cursor up/down keys. <table border="1" data-bbox="336 528 1401 719"> <thead> <tr> <th data-bbox="336 528 639 573">Display</th> <th data-bbox="639 528 1401 573">Description</th> </tr> </thead> <tbody> <tr> <td data-bbox="336 573 639 618">ECM TX</td> <td data-bbox="639 573 1401 618">Sets ECM transmission.</td> </tr> <tr> <td data-bbox="336 618 639 663">ECM RX</td> <td data-bbox="639 618 1401 663">Sets ECM reception.</td> </tr> <tr> <td data-bbox="336 663 639 719">CED FREQ.</td> <td data-bbox="639 663 1401 719">Sets the frequency of the CED signal.</td> </tr> </tbody> </table> <p data-bbox="288 763 624 792">Setting ECM transmission</p> <p data-bbox="288 799 1396 864">To be set to OFF when reduction of transmission costs is of higher priority than image quality. This should not be set to OFF when connecting to the IP (Internet Protocol) telephone line.</p> <ol data-bbox="304 871 919 900" style="list-style-type: none"> 1. Select the setting using the cursor up/down keys. <table border="1" data-bbox="336 911 1401 1055"> <thead> <tr> <th data-bbox="336 911 639 956">Display</th> <th data-bbox="639 911 1401 956">Description</th> </tr> </thead> <tbody> <tr> <td data-bbox="336 956 639 1001">ON</td> <td data-bbox="639 956 1401 1001">ECM transmission is enabled.</td> </tr> <tr> <td data-bbox="336 1001 639 1055">OFF</td> <td data-bbox="639 1001 1401 1055">ECM transmission is disabled.</td> </tr> </tbody> </table> <p data-bbox="336 1061 579 1090">* : Initial setting: ON</p> <ol data-bbox="304 1097 783 1126" style="list-style-type: none"> 2. Press the start key. The setting is set. <p data-bbox="288 1167 576 1196">Setting ECM reception</p> <p data-bbox="288 1202 1396 1267">To be set to OFF when reduction of transmission costs is of higher priority than image quality. This should not be set to OFF when connecting to the IP (Internet Protocol) telephone line.</p> <ol data-bbox="304 1274 919 1303" style="list-style-type: none"> 1. Select the setting using the cursor up/down keys. <table border="1" data-bbox="336 1314 1401 1458"> <thead> <tr> <th data-bbox="336 1314 639 1359">Display</th> <th data-bbox="639 1314 1401 1359">Description</th> </tr> </thead> <tbody> <tr> <td data-bbox="336 1359 639 1404">ON</td> <td data-bbox="639 1359 1401 1404">ECM reception is enabled.</td> </tr> <tr> <td data-bbox="336 1404 639 1458">OFF</td> <td data-bbox="639 1404 1401 1458">ECM reception is disabled.</td> </tr> </tbody> </table> <p data-bbox="336 1464 579 1494">* : Initial setting: ON</p> <ol data-bbox="304 1500 783 1529" style="list-style-type: none"> 2. Press the start key. The setting is set. <p data-bbox="288 1570 799 1599">Setting the frequency of the CED signal</p> <p data-bbox="288 1606 1433 1671">Sets the frequency of the CED signal. Used as one of the measures to improve transmission performance for international communications.</p> <ol data-bbox="304 1677 919 1706" style="list-style-type: none"> 1. Select the setting using the cursor up/down keys. <table border="1" data-bbox="336 1718 1401 1861"> <thead> <tr> <th data-bbox="336 1718 639 1762">Display</th> <th data-bbox="639 1718 1401 1762">Description</th> </tr> </thead> <tbody> <tr> <td data-bbox="336 1762 639 1807">2100</td> <td data-bbox="639 1762 1401 1807">2100 Hz</td> </tr> <tr> <td data-bbox="336 1807 639 1861">1100</td> <td data-bbox="639 1807 1401 1861">1100 Hz</td> </tr> </tbody> </table> <p data-bbox="336 1868 600 1897">* : Initial setting: 2100</p> <ol data-bbox="304 1904 783 1933" style="list-style-type: none"> 2. Press the start key. The setting is set. <p data-bbox="288 1973 438 2002">Completion</p> <p data-bbox="288 2009 1257 2038">Press the stop key. The screen for selecting a maintenance item No. is displayed.</p>	Display	Description	ECM TX	Sets ECM transmission.	ECM RX	Sets ECM reception.	CED FREQ.	Sets the frequency of the CED signal.	Display	Description	ON	ECM transmission is enabled.	OFF	ECM transmission is disabled.	Display	Description	ON	ECM reception is enabled.	OFF	ECM reception is disabled.	Display	Description	2100	2100 Hz	1100	1100 Hz
Display	Description																										
ECM TX	Sets ECM transmission.																										
ECM RX	Sets ECM reception.																										
CED FREQ.	Sets the frequency of the CED signal.																										
Display	Description																										
ON	ECM transmission is enabled.																										
OFF	ECM transmission is disabled.																										
Display	Description																										
ON	ECM reception is enabled.																										
OFF	ECM reception is disabled.																										
Display	Description																										
2100	2100 Hz																										
1100	1100 Hz																										

Item No.	Description																												
U632	<p data-bbox="288 241 710 275">Setting communication control 3</p> <p data-bbox="288 313 438 342">Description Makes settings for fax transmission regarding the communication.</p> <p data-bbox="288 416 387 445">Method</p> <ol data-bbox="304 450 1002 517" style="list-style-type: none"> 1. Press the start key. 2. Select the item to be set using the cursor up/down keys. <table border="1" data-bbox="336 528 1401 801"> <thead> <tr> <th data-bbox="336 528 639 573">Display</th> <th data-bbox="639 528 1401 573">Description</th> </tr> </thead> <tbody> <tr> <td data-bbox="336 573 639 618">DIS 4BYTE</td> <td data-bbox="639 573 1401 618">Sets the DIS signal to 4 bytes.</td> </tr> <tr> <td data-bbox="336 618 639 663">SHORT PRTCL TX</td> <td data-bbox="639 618 1401 663">Sets the short protocol transmission.</td> </tr> <tr> <td data-bbox="336 663 639 707">SHORT PRTCL RX</td> <td data-bbox="639 663 1401 707">Sets the reception of short protocol transmission.</td> </tr> <tr> <td data-bbox="336 707 639 801">NUM OF CNG(F/T)</td> <td data-bbox="639 707 1401 801">Sets the CNG detection times in the fax/telephone auto select mode.</td> </tr> </tbody> </table> <p data-bbox="288 846 699 875">Setting the DIS signal to 4 bytes</p> <p data-bbox="288 880 976 909">Sets if bit 33 and later bits of the DIS/DTC signal are sent.</p> <ol data-bbox="304 913 919 943" style="list-style-type: none"> 1. Select the setting using the cursor up/down keys. <table border="1" data-bbox="336 954 1401 1099"> <thead> <tr> <th data-bbox="336 954 639 999">Display</th> <th data-bbox="639 954 1401 999">Description</th> </tr> </thead> <tbody> <tr> <td data-bbox="336 999 639 1043">ON</td> <td data-bbox="639 999 1401 1043">Bit 33 and later bits of the DIS/DTC signal are not sent.</td> </tr> <tr> <td data-bbox="336 1043 639 1099">OFF</td> <td data-bbox="639 1043 1401 1099">Bit 33 and later bits of the DIS/DTC signal are sent.</td> </tr> </tbody> </table> <p data-bbox="336 1111 592 1140">* : Initial setting: OFF</p> <ol data-bbox="304 1144 780 1173" style="list-style-type: none"> 2. Press the start key. The setting is set. <p data-bbox="288 1211 794 1240">Setting the short protocol transmission</p> <p data-bbox="288 1245 855 1274">Sets if short protocol transmission is performed.</p> <ol data-bbox="304 1279 919 1308" style="list-style-type: none"> 1. Select the setting using the cursor up/down keys. <table border="1" data-bbox="336 1319 1401 1464"> <thead> <tr> <th data-bbox="336 1319 639 1364">Display</th> <th data-bbox="639 1319 1401 1364">Description</th> </tr> </thead> <tbody> <tr> <td data-bbox="336 1364 639 1408">ON</td> <td data-bbox="639 1364 1401 1408">Short protocol transmission is performed.</td> </tr> <tr> <td data-bbox="336 1408 639 1464">OFF</td> <td data-bbox="639 1408 1401 1464">Short protocol transmission is not performed.</td> </tr> </tbody> </table> <p data-bbox="336 1476 579 1505">* : Initial setting: ON</p> <ol data-bbox="304 1509 780 1538" style="list-style-type: none"> 2. Press the start key. The setting is set. <p data-bbox="288 1576 976 1606">Setting the reception of a short protocol transmission</p> <p data-bbox="288 1610 1123 1639">Selects whether to receive or ignore transmission using short protocol.</p> <p data-bbox="288 1644 1423 1744">If a short protocol transmission is received when an auto switching device is attached to the machine, communication problems, including auto switching inability, sometimes occur. Change the setting to ignore short protocol transmission to prevent such problems.</p> <ol data-bbox="304 1749 919 1778" style="list-style-type: none"> 1. Select the setting using the cursor up/down keys. <table border="1" data-bbox="336 1789 1401 1935"> <thead> <tr> <th data-bbox="336 1789 639 1834">Display</th> <th data-bbox="639 1789 1401 1834">Description</th> </tr> </thead> <tbody> <tr> <td data-bbox="336 1834 639 1879">ON</td> <td data-bbox="639 1834 1401 1879">Receives short protocol transmission.</td> </tr> <tr> <td data-bbox="336 1879 639 1935">OFF</td> <td data-bbox="639 1879 1401 1935">Ignores short protocol transmission.</td> </tr> </tbody> </table> <p data-bbox="336 1946 579 1975">* : Initial setting: ON</p> <ol data-bbox="304 1980 780 2009" style="list-style-type: none"> 2. Press the start key. The setting is set. 	Display	Description	DIS 4BYTE	Sets the DIS signal to 4 bytes.	SHORT PRTCL TX	Sets the short protocol transmission.	SHORT PRTCL RX	Sets the reception of short protocol transmission.	NUM OF CNG(F/T)	Sets the CNG detection times in the fax/telephone auto select mode.	Display	Description	ON	Bit 33 and later bits of the DIS/DTC signal are not sent.	OFF	Bit 33 and later bits of the DIS/DTC signal are sent.	Display	Description	ON	Short protocol transmission is performed.	OFF	Short protocol transmission is not performed.	Display	Description	ON	Receives short protocol transmission.	OFF	Ignores short protocol transmission.
Display	Description																												
DIS 4BYTE	Sets the DIS signal to 4 bytes.																												
SHORT PRTCL TX	Sets the short protocol transmission.																												
SHORT PRTCL RX	Sets the reception of short protocol transmission.																												
NUM OF CNG(F/T)	Sets the CNG detection times in the fax/telephone auto select mode.																												
Display	Description																												
ON	Bit 33 and later bits of the DIS/DTC signal are not sent.																												
OFF	Bit 33 and later bits of the DIS/DTC signal are sent.																												
Display	Description																												
ON	Short protocol transmission is performed.																												
OFF	Short protocol transmission is not performed.																												
Display	Description																												
ON	Receives short protocol transmission.																												
OFF	Ignores short protocol transmission.																												

Item No.	Description																				
U632	<p>Setting the CNG detection times in the fax/telephone auto select mode Sets the CNG detection times in the fax/telephone auto select mode.</p> <ol style="list-style-type: none"> Select the setting using the cursor up/down keys. <table border="1" data-bbox="335 353 1401 501"> <thead> <tr> <th>Display</th> <th>Description</th> </tr> </thead> <tbody> <tr> <td>1TIME</td> <td>Detects CNG once.</td> </tr> <tr> <td>2TIMES</td> <td>Detects CNG twice.</td> </tr> </tbody> </table> <p>* : Initial setting: 2TIMES</p> <ol style="list-style-type: none"> Press the start key. The setting is set. <p>Completion Press the stop key. The screen for selecting a maintenance item No. is displayed.</p>	Display	Description	1TIME	Detects CNG once.	2TIMES	Detects CNG twice.														
Display	Description																				
1TIME	Detects CNG once.																				
2TIMES	Detects CNG twice.																				
U633	<p>Setting communication control 4</p> <p>Description Makes settings for fax transmission regarding the communication.</p> <p>Purpose To reduce transmission errors when a low quality line is used.</p> <p>Method</p> <ol style="list-style-type: none"> Press the start key. Select the item to be set using the cursor up/down keys. <table border="1" data-bbox="335 1048 1401 1285"> <thead> <tr> <th>Display</th> <th>Description</th> </tr> </thead> <tbody> <tr> <td>V.34</td> <td>Enables or disables V.34 communication.</td> </tr> <tr> <td>V.34-3429Hz</td> <td>Sets the V.34 symbol speed (3429 Hz).</td> </tr> <tr> <td>DIS 2RES</td> <td>Sets the number of times of DIS signal reception.</td> </tr> <tr> <td>RTN CHECK</td> <td>Sets the reference for RTN signal output.</td> </tr> </tbody> </table> <p>Enabling/disabling V.34 communication Sets whether V.34 communication is enabled/disabled for transmission and reception.</p> <ol style="list-style-type: none"> Select the setting using the cursor up/down keys. <table border="1" data-bbox="335 1442 1401 1680"> <thead> <tr> <th>Display</th> <th>Description</th> </tr> </thead> <tbody> <tr> <td>ON</td> <td>V.34 communication is enabled for both transmission and reception.</td> </tr> <tr> <td>TX</td> <td>V.34 communication is enabled for transmission only.</td> </tr> <tr> <td>RX</td> <td>V.34 communication is enabled for reception only.</td> </tr> <tr> <td>OFF</td> <td>V.34 communication is disabled for both transmission and reception.</td> </tr> </tbody> </table> <p>* : Initial setting: ON</p> <ol style="list-style-type: none"> Press the start key. The setting is set. 	Display	Description	V.34	Enables or disables V.34 communication.	V.34-3429Hz	Sets the V.34 symbol speed (3429 Hz).	DIS 2RES	Sets the number of times of DIS signal reception.	RTN CHECK	Sets the reference for RTN signal output.	Display	Description	ON	V.34 communication is enabled for both transmission and reception.	TX	V.34 communication is enabled for transmission only.	RX	V.34 communication is enabled for reception only.	OFF	V.34 communication is disabled for both transmission and reception.
Display	Description																				
V.34	Enables or disables V.34 communication.																				
V.34-3429Hz	Sets the V.34 symbol speed (3429 Hz).																				
DIS 2RES	Sets the number of times of DIS signal reception.																				
RTN CHECK	Sets the reference for RTN signal output.																				
Display	Description																				
ON	V.34 communication is enabled for both transmission and reception.																				
TX	V.34 communication is enabled for transmission only.																				
RX	V.34 communication is enabled for reception only.																				
OFF	V.34 communication is disabled for both transmission and reception.																				

Item No.	Description																						
U633	<p>Setting the V.34 symbol speed (3429 Hz) Sets if the V.34 symbol speed 3429 Hz is used.</p> <ol style="list-style-type: none"> Select the setting using the cursor up/down keys. <table border="1" data-bbox="335 353 1401 501"> <thead> <tr> <th>Display</th> <th>Description</th> </tr> </thead> <tbody> <tr> <td>ON</td> <td>V.34 symbol speed 3429 Hz is used.</td> </tr> <tr> <td>OFF</td> <td>V.34 symbol speed 3429 Hz is not used.</td> </tr> </tbody> </table> <p>* : Initial setting: ON</p> <ol style="list-style-type: none"> Press the start key. The setting is set. <p>Setting the number of times of DIS signal reception Sets the number of times to receive the DIS signal to once or twice. Used as one of the correction measures for transmission errors and other problems.</p> <ol style="list-style-type: none"> Select the setting using the cursor up/down keys. <table border="1" data-bbox="335 761 1401 909"> <thead> <tr> <th>Display</th> <th>Description</th> </tr> </thead> <tbody> <tr> <td>ONCE</td> <td>Responds to the first signal.</td> </tr> <tr> <td>TWICE</td> <td>Responds to the second signal.</td> </tr> </tbody> </table> <p>* : Initial setting: ONCE</p> <ol style="list-style-type: none"> Press the start key. The setting is set. <p>Setting the reference for RTN signal output Sets the error line rate as the reference for RTN signal output. If transmission errors occur frequently due to the quality of the line, they can be reduced by lowering this setting.</p> <ol style="list-style-type: none"> Select the setting using the cursor up/down keys. <table border="1" data-bbox="335 1169 1401 1406"> <thead> <tr> <th>Display</th> <th>Description</th> </tr> </thead> <tbody> <tr> <td>5%</td> <td>Error line rate of 5%</td> </tr> <tr> <td>10%</td> <td>Error line rate of 10%</td> </tr> <tr> <td>15%</td> <td>Error line rate of 15%</td> </tr> <tr> <td>20%</td> <td>Error line rate of 20%</td> </tr> </tbody> </table> <p>* : Initial setting: 15%</p> <ol style="list-style-type: none"> Press the start key. The setting is set. <p>Completion Press the stop key. The screen for selecting a maintenance item No. is displayed.</p>	Display	Description	ON	V.34 symbol speed 3429 Hz is used.	OFF	V.34 symbol speed 3429 Hz is not used.	Display	Description	ONCE	Responds to the first signal.	TWICE	Responds to the second signal.	Display	Description	5%	Error line rate of 5%	10%	Error line rate of 10%	15%	Error line rate of 15%	20%	Error line rate of 20%
Display	Description																						
ON	V.34 symbol speed 3429 Hz is used.																						
OFF	V.34 symbol speed 3429 Hz is not used.																						
Display	Description																						
ONCE	Responds to the first signal.																						
TWICE	Responds to the second signal.																						
Display	Description																						
5%	Error line rate of 5%																						
10%	Error line rate of 10%																						
15%	Error line rate of 15%																						
20%	Error line rate of 20%																						

Item No.	Description																		
U634	<p>Setting communication control 5</p> <p>Description Sets the maximum number of error bytes judged acceptable when receiving a TCF signal. Used as a measure to ease transmission conditions if transmission errors occur.</p> <p>Setting</p> <ol style="list-style-type: none"> 1. Press the start key. 2. Change the setting using the cursor left/right keys or numeric keys. <table border="1" data-bbox="336 562 1402 658"> <thead> <tr> <th>Description</th> <th>Setting range</th> <th>Initial setting</th> </tr> </thead> <tbody> <tr> <td>Number of allowed error bytes when detecting TCF</td> <td>0 to 255</td> <td>0</td> </tr> </tbody> </table> <ol style="list-style-type: none"> 3. Press the start key. The value is set. <p>Completion Press the stop key. The screen for selecting a maintenance item No. is displayed.</p>	Description	Setting range	Initial setting	Number of allowed error bytes when detecting TCF	0 to 255	0												
Description	Setting range	Initial setting																	
Number of allowed error bytes when detecting TCF	0 to 255	0																	
U640	<p>Setting communication time 1</p> <p>Description Sets the detection time when one-shot detection is selected for remote switching. (This setting item will be displayed, but the setting made is ineffective.) Sets the detection time when continuous detection is selected for remote switching. (This setting item will be displayed, but the setting made is ineffective.)</p> <p>Method</p> <ol style="list-style-type: none"> 1. Press the start key. 2. Select the item to be set using the cursor up/down keys. <table border="1" data-bbox="336 1207 1402 1350"> <thead> <tr> <th>Display</th> <th>Description</th> </tr> </thead> <tbody> <tr> <td>TIME (ONE)</td> <td>Sets the one-shot detection time for remote switching.</td> </tr> <tr> <td>TIME (CONT)</td> <td>Sets the continuous detection time for remote switching.</td> </tr> </tbody> </table> <p>Setting the one-shot detection time for remote switching</p> <ol style="list-style-type: none"> 1. Change the setting using the cursor left/right keys. <table border="1" data-bbox="336 1469 1402 1565"> <thead> <tr> <th>Description</th> <th>Setting range</th> <th>Initial setting</th> </tr> </thead> <tbody> <tr> <td>One-shot detection time for remote switching</td> <td>0 to 255</td> <td>7</td> </tr> </tbody> </table> <ol style="list-style-type: none"> 2. Press the start key. The value is set. <p>Setting the continuous detection time for remote switching</p> <ol style="list-style-type: none"> 1. Change the setting using the cursor left/right keys. <table border="1" data-bbox="336 1720 1402 1816"> <thead> <tr> <th>Description</th> <th>Setting range</th> <th>Initial setting</th> </tr> </thead> <tbody> <tr> <td>Continuous detection time for remote switching</td> <td>0 to 255</td> <td>80</td> </tr> </tbody> </table> <ol style="list-style-type: none"> 2. Press the start key. The value is set. <p>Completion Press the stop key. The screen for selecting a maintenance item No. is displayed.</p>	Display	Description	TIME (ONE)	Sets the one-shot detection time for remote switching.	TIME (CONT)	Sets the continuous detection time for remote switching.	Description	Setting range	Initial setting	One-shot detection time for remote switching	0 to 255	7	Description	Setting range	Initial setting	Continuous detection time for remote switching	0 to 255	80
Display	Description																		
TIME (ONE)	Sets the one-shot detection time for remote switching.																		
TIME (CONT)	Sets the continuous detection time for remote switching.																		
Description	Setting range	Initial setting																	
One-shot detection time for remote switching	0 to 255	7																	
Description	Setting range	Initial setting																	
Continuous detection time for remote switching	0 to 255	80																	

Item No.	Description																														
U641	<p data-bbox="287 241 678 275">Setting communication time 2</p> <p data-bbox="287 313 438 342">Description Sets the time-out time for fax transmission.</p> <p data-bbox="287 380 399 409">Purpose To improve transmission performance for international communications mainly.</p> <p data-bbox="287 488 391 517">Method</p> <ol data-bbox="303 521 997 589" style="list-style-type: none"> 1. Press the start key. 2. Select the item to be set using the cursor up/down keys. <table border="1" data-bbox="335 600 1401 1025"> <thead> <tr> <th data-bbox="343 607 635 645">Display</th> <th data-bbox="635 607 1401 645">Description</th> </tr> </thead> <tbody> <tr> <td data-bbox="343 651 635 689">T0 TIME OUT</td> <td data-bbox="635 651 1401 689">Sets the T0 time-out time.</td> </tr> <tr> <td data-bbox="343 696 635 734">T1 TIME OUT</td> <td data-bbox="635 696 1401 734">Sets the T1 time-out time.</td> </tr> <tr> <td data-bbox="343 741 635 779">T2 TIME OUT</td> <td data-bbox="635 741 1401 779">Sets the T2 time-out time.</td> </tr> <tr> <td data-bbox="343 786 635 824">Ta TIME OUT</td> <td data-bbox="635 786 1401 824">Sets the Ta time-out time.</td> </tr> <tr> <td data-bbox="343 831 635 869">Tb1 TIME OUT</td> <td data-bbox="635 831 1401 869">Sets the Tb1 time-out time.</td> </tr> <tr> <td data-bbox="343 875 635 913">Tb2 TIME OUT</td> <td data-bbox="635 875 1401 913">Sets the Tb2 time-out time.</td> </tr> <tr> <td data-bbox="343 920 635 958">Tc TIME OUT</td> <td data-bbox="635 920 1401 958">Sets the Tc time-out time.</td> </tr> <tr> <td data-bbox="343 965 635 1003">Td TIME OUT</td> <td data-bbox="635 965 1401 1003">Sets the Td time-out time.</td> </tr> </tbody> </table> <p data-bbox="287 1070 646 1099">Setting the T0 time-out time</p> <p data-bbox="287 1104 1388 1205">Sets the time before detecting a CED or DIS signal after a dialing signal is sent. Depending on the quality of the exchange, or when the auto select function is selected at the destination unit, a line can be disconnected. Change the setting to prevent this problem.</p> <ol data-bbox="303 1209 933 1238" style="list-style-type: none"> 1. Change the setting using the cursor left/right keys. <table border="1" data-bbox="335 1249 1401 1350"> <thead> <tr> <th data-bbox="343 1256 973 1294">Description</th> <th data-bbox="973 1256 1189 1294">Setting range</th> <th data-bbox="1189 1256 1401 1294">Initial setting</th> </tr> </thead> <tbody> <tr> <td data-bbox="343 1301 973 1339">T0 time-out time</td> <td data-bbox="973 1301 1189 1339">30 to 90 s</td> <td data-bbox="1189 1301 1401 1339">56</td> </tr> </tbody> </table> <ol data-bbox="303 1355 766 1384" style="list-style-type: none"> 2. Press the start key. The value is set. <p data-bbox="287 1429 646 1458">Setting the T1 time-out time</p> <p data-bbox="287 1462 1428 1518">Sets the time before receiving the correct signal after call reception. No change is necessary for this maintenance item.</p> <ol data-bbox="303 1523 933 1552" style="list-style-type: none"> 1. Change the setting using the cursor left/right keys. <table border="1" data-bbox="335 1574 1401 1675"> <thead> <tr> <th data-bbox="343 1581 973 1619">Description</th> <th data-bbox="973 1581 1189 1619">Setting range</th> <th data-bbox="1189 1581 1401 1619">Initial setting</th> </tr> </thead> <tbody> <tr> <td data-bbox="343 1626 973 1664">T1 time-out time</td> <td data-bbox="973 1626 1189 1664">30 to 90 s</td> <td data-bbox="1189 1626 1401 1664">36</td> </tr> </tbody> </table> <ol data-bbox="303 1680 766 1709" style="list-style-type: none"> 2. Press the start key. The value is set. 	Display	Description	T0 TIME OUT	Sets the T0 time-out time.	T1 TIME OUT	Sets the T1 time-out time.	T2 TIME OUT	Sets the T2 time-out time.	Ta TIME OUT	Sets the Ta time-out time.	Tb1 TIME OUT	Sets the Tb1 time-out time.	Tb2 TIME OUT	Sets the Tb2 time-out time.	Tc TIME OUT	Sets the Tc time-out time.	Td TIME OUT	Sets the Td time-out time.	Description	Setting range	Initial setting	T0 time-out time	30 to 90 s	56	Description	Setting range	Initial setting	T1 time-out time	30 to 90 s	36
Display	Description																														
T0 TIME OUT	Sets the T0 time-out time.																														
T1 TIME OUT	Sets the T1 time-out time.																														
T2 TIME OUT	Sets the T2 time-out time.																														
Ta TIME OUT	Sets the Ta time-out time.																														
Tb1 TIME OUT	Sets the Tb1 time-out time.																														
Tb2 TIME OUT	Sets the Tb2 time-out time.																														
Tc TIME OUT	Sets the Tc time-out time.																														
Td TIME OUT	Sets the Td time-out time.																														
Description	Setting range	Initial setting																													
T0 time-out time	30 to 90 s	56																													
Description	Setting range	Initial setting																													
T1 time-out time	30 to 90 s	36																													

Item No.	Description																						
<p>U641</p>	<p>Setting the T2 time-out time The T2 time-out time decides the following. From CFR signal output to image data reception From image data reception to the next signal reception In ECM, from RNR signal detection to the next signal reception</p> <ol style="list-style-type: none"> Change the setting using the cursor left/right keys. <table border="1" data-bbox="335 459 1401 589"> <thead> <tr> <th>Description</th> <th>Setting range</th> <th>Initial setting</th> <th>Change in value per step</th> </tr> </thead> <tbody> <tr> <td>T2 time-out time</td> <td>1 to 255</td> <td>69</td> <td>100 ms</td> </tr> </tbody> </table> <ol style="list-style-type: none"> Press the start key. The value is set. <p>Setting the Ta time-out time In the fax/telephone auto select mode, sets the time to continue ringing an operator through the connected telephone after receiving a call as a fax machine (see figure 1-3-3). A fax signal is received within the Ta set time, or the fax mode is selected automatically when the time elapses. In fax/telephone auto select mode, change the setting when fax reception is unsuccessful or a telephone fails to receive a call.</p> <ol style="list-style-type: none"> Change the setting using the cursor left/right keys. <table border="1" data-bbox="335 918 1401 1014"> <thead> <tr> <th>Description</th> <th>Setting range</th> <th>Initial setting</th> </tr> </thead> <tbody> <tr> <td>Ta time-out time</td> <td>1 to 255</td> <td>30</td> </tr> </tbody> </table> <ol style="list-style-type: none"> Press the start key. The value is set. <div data-bbox="518 1086 1220 1456" data-label="Diagram"> <p>The diagram shows a horizontal timeline with five key events marked by dots: 'Ring detection', 'Line connection as a fax machine', 'Ring back tone send start', 'Rings', and 'Start of fax reception'. Brackets indicate time intervals: 'Tb1' is between 'Line connection as a fax machine' and 'Ring back tone send start'; 'Tb2' is between 'Line connection as a fax machine' and 'Rings'; 'Ta' is between 'Rings' and 'Start of fax reception'.</p> </div> <p>Figure 1-3-3 Ta/Tb1/Tb2 time-out time</p> <p>Setting the Tb1 time-out time In the fax/telephone auto select mode, sets the time to start sending the ring back tone after receiving a call as a fax machine (see figure 1-3-3). In fax/telephone auto select mode, change the setting when fax reception is unsuccessful or a telephone fails to receive a call.</p> <ol style="list-style-type: none"> Change the setting using the cursor left/right keys. <table border="1" data-bbox="335 1742 1401 1872"> <thead> <tr> <th>Description</th> <th>Setting range</th> <th>Initial setting</th> <th>Change in value per step</th> </tr> </thead> <tbody> <tr> <td>Tb1 time-out time</td> <td>1 to 255</td> <td>20</td> <td>100 ms</td> </tr> </tbody> </table> <ol style="list-style-type: none"> Press the start key. The value is set. 	Description	Setting range	Initial setting	Change in value per step	T2 time-out time	1 to 255	69	100 ms	Description	Setting range	Initial setting	Ta time-out time	1 to 255	30	Description	Setting range	Initial setting	Change in value per step	Tb1 time-out time	1 to 255	20	100 ms
Description	Setting range	Initial setting	Change in value per step																				
T2 time-out time	1 to 255	69	100 ms																				
Description	Setting range	Initial setting																					
Ta time-out time	1 to 255	30																					
Description	Setting range	Initial setting	Change in value per step																				
Tb1 time-out time	1 to 255	20	100 ms																				

Item No.	Description																				
U641	<p>Setting the Tb2 time-out time</p> <p>In the fax/telephone auto select mode, sets the time to start ringing an operator through the connected telephone after receiving a call as a fax machine (see figure 1-3-3). In the fax/telephone auto select mode, change the setting when fax reception is unsuccessful or a telephone fails to receive a call.</p> <p>1. Change the setting using the cursor left/right keys.</p> <table border="1" data-bbox="335 459 1404 593"> <thead> <tr> <th>Description</th> <th>Setting range</th> <th>Initial setting</th> <th>Change in value per step</th> </tr> </thead> <tbody> <tr> <td>Tb2 time-out time</td> <td>1 to 255</td> <td>80</td> <td>100 ms</td> </tr> </tbody> </table> <p>2. Press the start key. The value is set.</p> <p>Setting the Tc time-out time</p> <p>In the TAD mode, set the time to check if there are any triggers for shifting to fax reception after a connected telephone receives a call. Only the telephone function is available if shifting is not made within the set Tc time.</p> <p>In the TAD mode, change the setting when fax reception is unsuccessful or a telephone fails to receive a call.</p> <p>1. Change the setting using the cursor left/right keys.</p> <table border="1" data-bbox="335 918 1404 1019"> <thead> <tr> <th>Description</th> <th>Setting range</th> <th>Initial setting</th> </tr> </thead> <tbody> <tr> <td>Tc time-out time</td> <td>1 to 255</td> <td>60</td> </tr> </tbody> </table> <p>2. Press the start key. The value is set.</p> <p>Setting the Td time-out time</p> <p>Sets the length of the time required to determine silent status (fax), one of the triggers for Tc time check. In the TAD mode, change the setting when fax reception is unsuccessful or a telephone fails to receive a call. Be sure not to set it too short; otherwise, the mode may be shifted to fax while the unit is being used as a telephone.</p> <p>1. Change the setting using the cursor left/right keys.</p> <table border="1" data-bbox="335 1310 1404 1411"> <thead> <tr> <th>Description</th> <th>Setting range</th> <th>Initial setting</th> </tr> </thead> <tbody> <tr> <td>Td time-out time</td> <td>1 to 255</td> <td>9 (120 V)/6 (220-240 V)</td> </tr> </tbody> </table> <p>2. Press the start key. The value is set.</p> <p>Completion</p> <p>Press the stop key. The screen for selecting a maintenance item No. is displayed.</p>	Description	Setting range	Initial setting	Change in value per step	Tb2 time-out time	1 to 255	80	100 ms	Description	Setting range	Initial setting	Tc time-out time	1 to 255	60	Description	Setting range	Initial setting	Td time-out time	1 to 255	9 (120 V)/6 (220-240 V)
Description	Setting range	Initial setting	Change in value per step																		
Tb2 time-out time	1 to 255	80	100 ms																		
Description	Setting range	Initial setting																			
Tc time-out time	1 to 255	60																			
Description	Setting range	Initial setting																			
Td time-out time	1 to 255	9 (120 V)/6 (220-240 V)																			

Item No.	Description								
<p>U650</p>	<p>Setting modem 1</p> <p>Description Sets the G3 cable equalizer. Sets the modem detection level.</p> <p>Purpose Perform the following adjustment to make the equalizer compatible with the line characteristics. To improve the transmission performance when a low quality line is used.</p> <p>Method</p> <ol style="list-style-type: none"> 1. Press the start key. 2. Select the item to be set using the cursor up/down keys. <table border="1" data-bbox="336 633 1401 824"> <thead> <tr> <th data-bbox="336 633 643 683">Display</th> <th data-bbox="643 633 1401 683">Description</th> </tr> </thead> <tbody> <tr> <td data-bbox="336 683 643 732">REG. G3 TX EQR</td> <td data-bbox="643 683 1401 732">Sets the G3 transmission cable equalizer.</td> </tr> <tr> <td data-bbox="336 732 643 781">REG. G3 RX EQR</td> <td data-bbox="643 732 1401 781">Sets the G3 reception cable equalizer.</td> </tr> <tr> <td data-bbox="336 781 643 824">RX MODEM LEVEL</td> <td data-bbox="643 781 1401 824">Sets the modem detection level.</td> </tr> </tbody> </table> <p>Setting the G3 transmission cable equalizer</p> <ol style="list-style-type: none"> 1. Select [0dB], [4dB], [8dB] or [12dB] using the cursor up/down keys. * : Initial setting: 0dB 2. Press the start key. The setting is set. <p>Setting the G3 reception cable equalizer</p> <ol style="list-style-type: none"> 1. Select [0dB], [4dB], [8dB] or [12dB] using the cursor up/down keys. * : Initial setting: 0dB 2. Press the start key. The setting is set. <p>Setting the modem detection level</p> <ol style="list-style-type: none"> 1. Select [33dBm], [38dBm], [43dBm] or [48dBm] using the cursor up/down keys. * : Initial setting: 43dBm 2. Press the start key. The setting is set. <p>Completion Press the stop key. The screen for selecting a maintenance item No. is displayed.</p>	Display	Description	REG. G3 TX EQR	Sets the G3 transmission cable equalizer.	REG. G3 RX EQR	Sets the G3 reception cable equalizer.	RX MODEM LEVEL	Sets the modem detection level.
Display	Description								
REG. G3 TX EQR	Sets the G3 transmission cable equalizer.								
REG. G3 RX EQR	Sets the G3 reception cable equalizer.								
RX MODEM LEVEL	Sets the modem detection level.								

Item No.	Description																
U651	<p data-bbox="287 241 510 275">Setting modem 2</p> <p data-bbox="287 313 438 342">Description Sets the modem output level. Sets the DTMF output level of a push-button dial telephone.</p> <p data-bbox="287 421 399 450">Purpose Used if problems occur when sending a signal with a push-button dial telephone.</p> <p data-bbox="287 521 383 551">Setting</p> <ol data-bbox="303 555 1125 656" style="list-style-type: none"> 1. Press the start key. 2. Select the item to be set using the cursor up/down keys. 3. Change the setting using the cursor left/right keys or numeric keys. <table border="1" data-bbox="335 667 1388 963"> <thead> <tr> <th data-bbox="343 674 566 712">Display</th> <th data-bbox="566 674 957 712">Description</th> <th data-bbox="957 674 1157 712">Setting range</th> <th data-bbox="1157 674 1380 712">Initial setting</th> </tr> </thead> <tbody> <tr> <td data-bbox="343 719 566 795">SGL LV MDM</td> <td data-bbox="566 719 957 795">Modem output level</td> <td data-bbox="957 719 1157 795">1 to 15</td> <td data-bbox="1157 719 1380 795">9 (120 V) 10 (220-240 V)</td> </tr> <tr> <td data-bbox="343 801 566 878">DTMF LV(C)</td> <td data-bbox="566 801 957 878">DTMF output level (main value)</td> <td data-bbox="957 801 1157 878">0 to 15.0</td> <td data-bbox="1157 801 1380 878">5 (120 V) 10.5 (220-240 V)</td> </tr> <tr> <td data-bbox="343 884 566 960">DTMF LV(D)</td> <td data-bbox="566 884 957 960">DTMF output level (level difference)</td> <td data-bbox="957 884 1157 960">0 to 5.5</td> <td data-bbox="1157 884 1380 960">2 (120 V) 2.5 (220-240 V)</td> </tr> </tbody> </table> <ol data-bbox="303 974 782 1003" style="list-style-type: none"> 4. Press the start key. The setting is set. <p data-bbox="287 1041 438 1070">Completion Press the stop key. The screen for selecting a maintenance item No. is displayed.</p>	Display	Description	Setting range	Initial setting	SGL LV MDM	Modem output level	1 to 15	9 (120 V) 10 (220-240 V)	DTMF LV(C)	DTMF output level (main value)	0 to 15.0	5 (120 V) 10.5 (220-240 V)	DTMF LV(D)	DTMF output level (level difference)	0 to 5.5	2 (120 V) 2.5 (220-240 V)
Display	Description	Setting range	Initial setting														
SGL LV MDM	Modem output level	1 to 15	9 (120 V) 10 (220-240 V)														
DTMF LV(C)	DTMF output level (main value)	0 to 15.0	5 (120 V) 10.5 (220-240 V)														
DTMF LV(D)	DTMF output level (level difference)	0 to 5.5	2 (120 V) 2.5 (220-240 V)														

Item No.	Description																								
U660	<p data-bbox="287 241 502 275">Setting the NCU</p> <p data-bbox="287 313 438 347">Description Makes setting regarding the network control unit (NCU).</p> <p data-bbox="287 380 399 414">Purpose To be set when installing the facsimile kit.</p> <p data-bbox="287 481 391 515">Method</p> <ol data-bbox="303 519 997 586" style="list-style-type: none"> 1. Press the start key. 2. Select the item to be set using the cursor up/down keys. <table border="1" data-bbox="335 593 1404 884"> <thead> <tr> <th data-bbox="343 600 638 645">Display</th> <th data-bbox="638 600 1396 645">Description</th> </tr> </thead> <tbody> <tr> <td data-bbox="343 645 638 689">EXCHANGE</td> <td data-bbox="638 645 1396 689">Sets the connection to PBX/PSTN.</td> </tr> <tr> <td data-bbox="343 689 638 734">DIAL TONE</td> <td data-bbox="638 689 1396 734">Sets PSTN dial tone detection.</td> </tr> <tr> <td data-bbox="343 734 638 779">BUSY TONE</td> <td data-bbox="638 734 1396 779">Sets busy tone detection.</td> </tr> <tr> <td data-bbox="343 779 638 824">PBX SETTING</td> <td data-bbox="638 779 1396 824">Setting for a PBX.</td> </tr> <tr> <td data-bbox="343 824 638 869">DC LOOP</td> <td data-bbox="638 824 1396 869">Sets the loop current detection before dialing.</td> </tr> </tbody> </table> <p data-bbox="287 929 758 963">Setting the connection to PBX/PSTN</p> <p data-bbox="287 967 1332 1001">Selects if a fax is to be connected to either a PBX or public switched telephone network.</p> <ol data-bbox="303 1003 917 1037" style="list-style-type: none"> 1. Select the setting using the cursor up/down keys. <table border="1" data-bbox="335 1041 1404 1187"> <thead> <tr> <th data-bbox="343 1048 638 1093">Display</th> <th data-bbox="638 1048 1396 1093">Description</th> </tr> </thead> <tbody> <tr> <td data-bbox="343 1093 638 1137">PSTN</td> <td data-bbox="638 1093 1396 1137">Connected to the public switched telephone network.</td> </tr> <tr> <td data-bbox="343 1137 638 1182">PBX</td> <td data-bbox="638 1137 1396 1182">Connected to a PBX.</td> </tr> </tbody> </table> <p data-bbox="335 1198 614 1232">* : Initial setting: PSTN</p> <ol data-bbox="303 1234 782 1267" style="list-style-type: none"> 2. Press the start key. The setting is set. <p data-bbox="287 1299 710 1332">Setting PSTN dial tone detection</p> <p data-bbox="287 1337 1428 1404">Selects if the dial tone is detected to check the telephone is off the hook when a fax is connected to a public switched telephone network.</p> <ol data-bbox="303 1406 917 1440" style="list-style-type: none"> 1. Select the setting using the cursor up/down keys. <table border="1" data-bbox="335 1444 1404 1590"> <thead> <tr> <th data-bbox="343 1451 638 1496">Display</th> <th data-bbox="638 1451 1396 1496">Description</th> </tr> </thead> <tbody> <tr> <td data-bbox="343 1496 638 1541">ON</td> <td data-bbox="638 1496 1396 1541">Detects the dial tone.</td> </tr> <tr> <td data-bbox="343 1541 638 1585">OFF</td> <td data-bbox="638 1541 1396 1585">Does not detect the dial tone.</td> </tr> </tbody> </table> <p data-bbox="335 1601 582 1635">* : Initial setting: ON</p> <ol data-bbox="303 1637 782 1671" style="list-style-type: none"> 2. Press the start key. The setting is set. 	Display	Description	EXCHANGE	Sets the connection to PBX/PSTN.	DIAL TONE	Sets PSTN dial tone detection.	BUSY TONE	Sets busy tone detection.	PBX SETTING	Setting for a PBX.	DC LOOP	Sets the loop current detection before dialing.	Display	Description	PSTN	Connected to the public switched telephone network.	PBX	Connected to a PBX.	Display	Description	ON	Detects the dial tone.	OFF	Does not detect the dial tone.
Display	Description																								
EXCHANGE	Sets the connection to PBX/PSTN.																								
DIAL TONE	Sets PSTN dial tone detection.																								
BUSY TONE	Sets busy tone detection.																								
PBX SETTING	Setting for a PBX.																								
DC LOOP	Sets the loop current detection before dialing.																								
Display	Description																								
PSTN	Connected to the public switched telephone network.																								
PBX	Connected to a PBX.																								
Display	Description																								
ON	Detects the dial tone.																								
OFF	Does not detect the dial tone.																								

Item No.	Description																				
U660	<p>Setting busy tone detection When a fax signal is sent, sets whether the line is disconnected immediately after a busy tone is detected, or the busy tone is not detected and the line remains connected until T0 time-out time. Fax transmission may fail due to incorrect busy tone detection. When set to 2, this problem may be prevented. However, the line is not disconnected within the T0 time-out time even if the destination line is busy.</p> <p>1. Select the setting using the cursor up/down keys.</p> <table border="1" data-bbox="335 492 1404 638"> <thead> <tr> <th>Display</th> <th>Description</th> </tr> </thead> <tbody> <tr> <td>ON</td> <td>Detects busy tone.</td> </tr> <tr> <td>OFF</td> <td>Does not detect busy tone.</td> </tr> </tbody> </table> <p>* : Initial setting: ON</p> <p>2. Press the start key. The setting is set.</p> <p>Setting for a PBX Selects the mode to connect an outside call when connected to a PBX. According to the type of the PBX connected, select the mode to connect an outside call.</p> <p>1. Select the setting using the cursor up/down keys.</p> <table border="1" data-bbox="335 896 1404 1086"> <thead> <tr> <th>Display</th> <th>Description</th> </tr> </thead> <tbody> <tr> <td>EARTH</td> <td>Earth mode</td> </tr> <tr> <td>FLASH</td> <td>Flashing mode</td> </tr> <tr> <td>LOOP</td> <td>Code number mode</td> </tr> </tbody> </table> <p>* : Initial setting: LOOP</p> <p>2. Press the start key. The setting is set.</p> <p>Setting the loop current detection before dialing Sets if the loop current detection is performed before dialing.</p> <p>1. Select the setting using the cursor up/down keys.</p> <table border="1" data-bbox="335 1321 1404 1467"> <thead> <tr> <th>Display</th> <th>Description</th> </tr> </thead> <tbody> <tr> <td>ON</td> <td>Performs loop current detection before dialing.</td> </tr> <tr> <td>OFF</td> <td>Does not perform loop current detection before dialing.</td> </tr> </tbody> </table> <p>* : Initial setting: ON</p> <p>2. Press the start key. The setting is set.</p> <p>Completion Press the stop key. The screen for selecting a maintenance item No. is displayed.</p>	Display	Description	ON	Detects busy tone.	OFF	Does not detect busy tone.	Display	Description	EARTH	Earth mode	FLASH	Flashing mode	LOOP	Code number mode	Display	Description	ON	Performs loop current detection before dialing.	OFF	Does not perform loop current detection before dialing.
Display	Description																				
ON	Detects busy tone.																				
OFF	Does not detect busy tone.																				
Display	Description																				
EARTH	Earth mode																				
FLASH	Flashing mode																				
LOOP	Code number mode																				
Display	Description																				
ON	Performs loop current detection before dialing.																				
OFF	Does not perform loop current detection before dialing.																				

Item No.	Description																				
<p>U670</p>	<p>Outputting lists</p> <p>Description Outputs a list of data regarding fax transmissions. Printing a list is disabled either when a job is remaining in the buffer or when [Pause All Print Jobs] is pressed to halt printing.</p> <p>Purpose To check conditions of use, settings and transmission procedures of the fax.</p> <p>Method</p> <ol style="list-style-type: none"> 1. Press the start key. 2. Select the item to be output using the cursor up/down keys. 3. Press the start key. The selected list is output. <table border="1" data-bbox="336 701 1401 1283"> <thead> <tr> <th data-bbox="336 701 643 750">Display</th> <th data-bbox="643 701 1401 750">Description</th> </tr> </thead> <tbody> <tr> <td data-bbox="336 750 643 835">SETTING LIST</td> <td data-bbox="643 750 1401 835">Outputs a list of software switches, self telephone number, confidential boxes, ROM versions and other information.</td> </tr> <tr> <td data-bbox="336 835 643 913">ACTION LIST</td> <td data-bbox="643 835 1401 913">Outputs a list of error history, transmission line details and other information.</td> </tr> <tr> <td data-bbox="336 913 643 992">SELF ST REPORT</td> <td data-bbox="643 913 1401 992">Outputs a list of settings in maintenance mode (own-status report) regarding fax transmission only.</td> </tr> <tr> <td data-bbox="336 992 643 1041">PROTOCOL LIST</td> <td data-bbox="643 992 1401 1041">Outputs a list of transmission procedures.</td> </tr> <tr> <td data-bbox="336 1041 643 1090">ERROR LIST</td> <td data-bbox="643 1041 1401 1090">Outputs a list of error.</td> </tr> <tr> <td data-bbox="336 1090 643 1140">ADDR BOOK (No.)</td> <td data-bbox="643 1090 1401 1140">Outputs address book in order IDs were added</td> </tr> <tr> <td data-bbox="336 1140 643 1189">ADDR BOOK (Name)</td> <td data-bbox="643 1140 1401 1189">Outputs address book in order of names</td> </tr> <tr> <td data-bbox="336 1189 643 1238">ONE-TOUCH LIST</td> <td data-bbox="643 1189 1401 1238">Outputs a list of one-touch.</td> </tr> <tr> <td data-bbox="336 1238 643 1283">GROUP LIST</td> <td data-bbox="643 1238 1401 1283">Outputs a list of group.</td> </tr> </tbody> </table> <p>Completion Press the stop key. The screen for selecting a maintenance item No. is displayed.</p>	Display	Description	SETTING LIST	Outputs a list of software switches, self telephone number, confidential boxes, ROM versions and other information.	ACTION LIST	Outputs a list of error history, transmission line details and other information.	SELF ST REPORT	Outputs a list of settings in maintenance mode (own-status report) regarding fax transmission only.	PROTOCOL LIST	Outputs a list of transmission procedures.	ERROR LIST	Outputs a list of error.	ADDR BOOK (No.)	Outputs address book in order IDs were added	ADDR BOOK (Name)	Outputs address book in order of names	ONE-TOUCH LIST	Outputs a list of one-touch.	GROUP LIST	Outputs a list of group.
Display	Description																				
SETTING LIST	Outputs a list of software switches, self telephone number, confidential boxes, ROM versions and other information.																				
ACTION LIST	Outputs a list of error history, transmission line details and other information.																				
SELF ST REPORT	Outputs a list of settings in maintenance mode (own-status report) regarding fax transmission only.																				
PROTOCOL LIST	Outputs a list of transmission procedures.																				
ERROR LIST	Outputs a list of error.																				
ADDR BOOK (No.)	Outputs address book in order IDs were added																				
ADDR BOOK (Name)	Outputs address book in order of names																				
ONE-TOUCH LIST	Outputs a list of one-touch.																				
GROUP LIST	Outputs a list of group.																				

Item No.	Description																		
U695	<p data-bbox="287 241 598 273">FAX function customize</p> <p data-bbox="287 313 438 344">Description Sets fax batch transmission ON/OFF. Also changes the print size priority at the time of small size reception.</p> <p data-bbox="287 416 399 448">Purpose To be executed as required.</p> <p data-bbox="287 519 383 551">Setting</p> <p data-bbox="303 555 917 586">1. Select the setting using the cursor up/down keys.</p> <table border="1" data-bbox="335 595 1401 741"> <thead> <tr> <th data-bbox="343 600 641 645">Display</th> <th data-bbox="641 600 1401 645">Description</th> </tr> </thead> <tbody> <tr> <td data-bbox="343 645 641 689">FAX BULK TX</td> <td data-bbox="641 645 1401 689">fax batch transmission ON/OFF</td> </tr> <tr> <td data-bbox="343 689 641 741">A5 PT PRI CHG</td> <td data-bbox="641 689 1401 741">Change of print size priority at the time of small size reception</td> </tr> </tbody> </table> <p data-bbox="287 786 590 817">Setting: [FAX BULK TX]</p> <p data-bbox="303 822 917 853">1. Select ON or OFF using the cursor left/right keys.</p> <table border="1" data-bbox="335 862 1401 1008"> <thead> <tr> <th data-bbox="343 866 641 911">Display</th> <th data-bbox="641 866 1401 911">Description</th> </tr> </thead> <tbody> <tr> <td data-bbox="343 911 641 956">ON</td> <td data-bbox="641 911 1401 956">Fax batch transmission is enabled.</td> </tr> <tr> <td data-bbox="343 956 641 1008">OFF</td> <td data-bbox="641 956 1401 1008">Fax batch transmission is disabled.</td> </tr> </tbody> </table> <p data-bbox="335 1016 582 1048">* : Initial setting: ON</p> <p data-bbox="303 1052 782 1084">2. Press the start key. The setting is set.</p> <p data-bbox="287 1122 614 1153">Setting: [A5 PT PRI CHG]</p> <p data-bbox="303 1158 917 1189">1. Select ON or OFF using the cursor left/right keys.</p> <table border="1" data-bbox="335 1198 1401 1344"> <thead> <tr> <th data-bbox="343 1202 641 1247">Display</th> <th data-bbox="641 1202 1401 1247">Description</th> </tr> </thead> <tbody> <tr> <td data-bbox="343 1247 641 1292">ON</td> <td data-bbox="641 1247 1401 1292">At the time of A5 size reception: A5→B5→A4</td> </tr> <tr> <td data-bbox="343 1292 641 1344">OFF</td> <td data-bbox="641 1292 1401 1344">At the time of A5 size reception: A5→A4→B5</td> </tr> </tbody> </table> <p data-bbox="335 1352 590 1384">* : Initial setting: OFF</p> <p data-bbox="303 1388 782 1420">2. Press the start key. The setting is set.</p> <p data-bbox="287 1458 438 1489">Completion</p> <p data-bbox="287 1494 1252 1525">Press the stop key. The screen for selecting a maintenance item No. is displayed.</p>	Display	Description	FAX BULK TX	fax batch transmission ON/OFF	A5 PT PRI CHG	Change of print size priority at the time of small size reception	Display	Description	ON	Fax batch transmission is enabled.	OFF	Fax batch transmission is disabled.	Display	Description	ON	At the time of A5 size reception: A5→B5→A4	OFF	At the time of A5 size reception: A5→A4→B5
Display	Description																		
FAX BULK TX	fax batch transmission ON/OFF																		
A5 PT PRI CHG	Change of print size priority at the time of small size reception																		
Display	Description																		
ON	Fax batch transmission is enabled.																		
OFF	Fax batch transmission is disabled.																		
Display	Description																		
ON	At the time of A5 size reception: A5→B5→A4																		
OFF	At the time of A5 size reception: A5→A4→B5																		

Item No.	Description																																														
U699	<p data-bbox="287 241 670 275">Setting the software switches</p> <p data-bbox="287 313 438 342">Description</p> <p data-bbox="287 347 1045 376">Sets the software switches on the FAX control PWB individually.</p> <p data-bbox="287 383 399 412">Purpose</p> <p data-bbox="287 416 1364 517">To change the setting when a problem such as split output of received originals occurs. Since the communication performance is largely affected, normally this setting need not be changed.</p> <p data-bbox="287 555 391 584">Method</p> <ol data-bbox="303 589 1396 790" style="list-style-type: none"> 1. Press the start key. 2. Press [SW No.]. 3. Enter the desired software switch number (3 digits) using the numeric keys and press the enter key. 4. Use numeric keys 7 to 0 to switch each bit between 0 and 1. 5. Press the start key to set the value. <p data-bbox="287 831 438 860">Completion</p> <p data-bbox="287 864 1252 893">Press the stop key. The screen for selecting a maintenance item No. is displayed.</p> <p data-bbox="287 934 1101 963">List of Software Switches of Which the Setting Can Be Changed</p> <p data-bbox="287 1003 758 1032"><Communication control procedure></p> <table border="1" data-bbox="335 1043 1401 2004"> <thead> <tr> <th data-bbox="343 1055 422 1084">No.</th> <th data-bbox="422 1055 590 1084">Bit</th> <th data-bbox="590 1055 1393 1084">Item</th> </tr> </thead> <tbody> <tr> <td data-bbox="343 1095 422 1124" rowspan="2">36</td> <td data-bbox="422 1095 590 1124">7654</td> <td data-bbox="590 1095 1393 1124">Coding format in transmission</td> </tr> <tr> <td data-bbox="422 1135 590 1164">3210</td> <td data-bbox="590 1135 1393 1164">Coding format in reception</td> </tr> <tr> <td data-bbox="343 1176 422 1205" rowspan="6">37</td> <td data-bbox="422 1176 590 1205">5</td> <td data-bbox="590 1176 1393 1205">33600 bps/V34</td> </tr> <tr> <td data-bbox="422 1216 590 1245">4</td> <td data-bbox="590 1216 1393 1245">31200 bps/V34</td> </tr> <tr> <td data-bbox="422 1256 590 1285">3</td> <td data-bbox="590 1256 1393 1285">28800 bps/V34</td> </tr> <tr> <td data-bbox="422 1296 590 1326">2</td> <td data-bbox="590 1296 1393 1326">26400 bps/V34</td> </tr> <tr> <td data-bbox="422 1337 590 1366">1</td> <td data-bbox="590 1337 1393 1366">24000 bps/V34</td> </tr> <tr> <td data-bbox="422 1377 590 1406">0</td> <td data-bbox="590 1377 1393 1406">21600 bps/V34</td> </tr> <tr> <td data-bbox="343 1417 422 1447" rowspan="8">38</td> <td data-bbox="422 1417 590 1447">7</td> <td data-bbox="590 1417 1393 1447">19200 bps/V34</td> </tr> <tr> <td data-bbox="422 1458 590 1487">6</td> <td data-bbox="590 1458 1393 1487">16800 bps/V34</td> </tr> <tr> <td data-bbox="422 1498 590 1527">5</td> <td data-bbox="590 1498 1393 1527">14400 bps/V34</td> </tr> <tr> <td data-bbox="422 1538 590 1568">4</td> <td data-bbox="590 1538 1393 1568">12000 bps/V34</td> </tr> <tr> <td data-bbox="422 1579 590 1608">3</td> <td data-bbox="590 1579 1393 1608">9600 bps/V34</td> </tr> <tr> <td data-bbox="422 1619 590 1648">2</td> <td data-bbox="590 1619 1393 1648">7200 bps/V34</td> </tr> <tr> <td data-bbox="422 1659 590 1688">1</td> <td data-bbox="590 1659 1393 1688">4800 bps/V34</td> </tr> <tr> <td data-bbox="422 1700 590 1729">0</td> <td data-bbox="590 1700 1393 1729">2400 bps/V34</td> </tr> <tr> <td data-bbox="343 1740 422 1769">41</td> <td data-bbox="422 1740 590 1769">3</td> <td data-bbox="590 1740 1393 1769">FSK detection in V.8</td> </tr> <tr> <td data-bbox="343 1780 422 1809" rowspan="2">42</td> <td data-bbox="422 1780 590 1809">4</td> <td data-bbox="590 1780 1393 1809">4800 bps when low-speed setting is active</td> </tr> <tr> <td data-bbox="422 1821 590 1850">2</td> <td data-bbox="590 1821 1393 1850">FIF length in transmission of more than 4 times of DIS/DTC signal</td> </tr> </tbody> </table>	No.	Bit	Item	36	7654	Coding format in transmission	3210	Coding format in reception	37	5	33600 bps/V34	4	31200 bps/V34	3	28800 bps/V34	2	26400 bps/V34	1	24000 bps/V34	0	21600 bps/V34	38	7	19200 bps/V34	6	16800 bps/V34	5	14400 bps/V34	4	12000 bps/V34	3	9600 bps/V34	2	7200 bps/V34	1	4800 bps/V34	0	2400 bps/V34	41	3	FSK detection in V.8	42	4	4800 bps when low-speed setting is active	2	FIF length in transmission of more than 4 times of DIS/DTC signal
No.	Bit	Item																																													
36	7654	Coding format in transmission																																													
	3210	Coding format in reception																																													
37	5	33600 bps/V34																																													
	4	31200 bps/V34																																													
	3	28800 bps/V34																																													
	2	26400 bps/V34																																													
	1	24000 bps/V34																																													
	0	21600 bps/V34																																													
38	7	19200 bps/V34																																													
	6	16800 bps/V34																																													
	5	14400 bps/V34																																													
	4	12000 bps/V34																																													
	3	9600 bps/V34																																													
	2	7200 bps/V34																																													
	1	4800 bps/V34																																													
	0	2400 bps/V34																																													
41	3	FSK detection in V.8																																													
42	4	4800 bps when low-speed setting is active																																													
	2	FIF length in transmission of more than 4 times of DIS/DTC signal																																													

Item No.	Description		
U699	<Communication time setting>		
	No.	Bit	Item
	53	76543210	T3 timeout setting
	54	76543210	T4 timeout setting (automatic equipment)
	55	76543210	T5 timeout setting
	60	76543210	Time before transmission of CNG (1100 Hz) signal
	63	76543210	T0 timeout setting (manual equipment)
	64	7	Phase C timeout in ECM reception
	66	76543210	Timeout 1 in countermeasures against echo
	68	76543210	Timeout for FSK detection start in V.8
	<Modem setting>		
	No.	Bit	Item
	89	76543	RX gain adjust
	<NCU setting>		
	No.	Bit	Item
	121	7654	Dial tone/busy tone detection pattern
	122	7654	Busy tone detection pattern
		1	Busy tone detection in automatic FAX/TEL switching
	125	76543210	Access code registration for connection to PSTN
	126	7654	FAX/TEL automatic switching ringback tone ON/OFF cycle
	<Calling time setting>		
	No.	Bit	Item
	133	76543210	DTMF signal transmission time
	134	76543210	DTMF signal pause time
	141	76543210	Ringer detection cycle (minimum)
	142	76543210	Ringer detection cycle (maximum)
	143	76543210	Ringer ON time detection
	144	76543210	Ringer OFF time detection
145	76543210	Ringer OFF non-detection time	
147	76543210	Dial tone detection time (continuous tone)	
148	76543210	Allowable dial tone interruption time	
149	76543210	Time for transmitting selection signal after closing the DC circuit	
151	76543210	Ringer frequency detection invalid time	

Item No.	Description
U910	<p data-bbox="287 241 654 275">Clearing the black ratio data</p> <p data-bbox="287 313 438 347">Description</p> <p data-bbox="287 347 917 380">Clears the accumulated black ratio data for A4 sheet.</p> <p data-bbox="287 380 399 414">Purpose</p> <p data-bbox="287 414 1133 448">To clear data as required at times such as during maintenance service.</p> <p data-bbox="287 481 391 515">Method</p> <ol data-bbox="303 515 1093 616" style="list-style-type: none">1. Press the start key.2. Select [ALL CLEAR] using the cursor up/down keys.3. Press the start key. The accumulated black ratio data is cleared. <p data-bbox="287 660 438 694">Completion</p> <p data-bbox="287 694 1252 728">Press the stop key. The screen for selecting a maintenance item No. is displayed.</p>

Item No.	Description																								
U917	<p>Setting backup data reading/writing</p> <p>Description Retrieves the backup data to a USB memory from the machine; or writes the data from the USB memory to the machine.</p> <p>Purpose To store and write data when replacing the control PWB.</p> <p>Method</p> <ol style="list-style-type: none"> Press the power key on the operation panel, and after verifying the power indicator has gone off, switch off the power switch. Insert USB memory in USB memory slot. Turn the power switch on. Wait for 10 seconds to allow the machine to recognize the USB memory. Enter the maintenance item. Press the start key. Select [Export] or [Import] using the cursor up/down keys and press the start key. <table border="1" data-bbox="335 840 1404 985"> <thead> <tr> <th>Display</th> <th>Description</th> </tr> </thead> <tbody> <tr> <td>IMPORT</td> <td>Writing data from the USB memory to the machine</td> </tr> <tr> <td>EXPORT</td> <td>Retrieving from the machine to a USB memory</td> </tr> </tbody> </table> <ol style="list-style-type: none"> Select the item using the cursor up/down keys. <table border="1" data-bbox="335 1041 1404 1556"> <thead> <tr> <th>Display</th> <th>Description</th> <th>Depending data</th> </tr> </thead> <tbody> <tr> <td>ADDRESS BOOK</td> <td>Address book</td> <td>-</td> </tr> <tr> <td>JOB ACCNT.</td> <td>Job accounting</td> <td>-</td> </tr> <tr> <td>ONE TOUCH USER PROGRAM</td> <td>Information on one-touch key User managements Program information</td> <td>Address book Job accounting Job accountings and user managements</td> </tr> <tr> <td>DOCUMENT BOX</td> <td>Document box information</td> <td>Job accountings and user managements</td> </tr> <tr> <td>FAX FORWARD</td> <td>FAX transfer information</td> <td>Job accountings, user managements and document box information</td> </tr> </tbody> </table> <p>* : Since data are dependent with each other, data other than those assigned are also retrieved or written in.</p> <ol style="list-style-type: none"> Select [ON] using the cursor left/right keys. Press the start key. Starts reading or writing. The progress of selected item is displayed in %. When an error occurs, the operation is canceled and an error code is displayed. When normally completed, [FIN] is displayed. Turn the power switch off and on after completing writing when selecting [IMPORT]. 	Display	Description	IMPORT	Writing data from the USB memory to the machine	EXPORT	Retrieving from the machine to a USB memory	Display	Description	Depending data	ADDRESS BOOK	Address book	-	JOB ACCNT.	Job accounting	-	ONE TOUCH USER PROGRAM	Information on one-touch key User managements Program information	Address book Job accounting Job accountings and user managements	DOCUMENT BOX	Document box information	Job accountings and user managements	FAX FORWARD	FAX transfer information	Job accountings, user managements and document box information
Display	Description																								
IMPORT	Writing data from the USB memory to the machine																								
EXPORT	Retrieving from the machine to a USB memory																								
Display	Description	Depending data																							
ADDRESS BOOK	Address book	-																							
JOB ACCNT.	Job accounting	-																							
ONE TOUCH USER PROGRAM	Information on one-touch key User managements Program information	Address book Job accounting Job accountings and user managements																							
DOCUMENT BOX	Document box information	Job accountings and user managements																							
FAX FORWARD	FAX transfer information	Job accountings, user managements and document box information																							

Item No.	Description			
U917	Error Codes			
	Codes	Description	Codes	Description
	e002	Parameter error	e31e	User managements error
	e003	File write error	e31f	User managements open error
	e004	File initialization error	e320	User managements error
	e005	File error	e410	Box file open error
	e006	Processing error	e411	Box error in writing
	e010	Address book clear error (contact)	e412	Box error in reading
	e011	Address book open error (contact)	e413	Box list error
	e012	Address book list error (contact)	e414	Box list error
	e013	Address book list error (contact)	e415	Box error
	e014	Address book clear error (group)	e416	Box error
	e015	Address book open error (group)	e417	Box open error
	e016	Address book list error (group)	e418	Box close error
	e017	Address book list error (group)	e419	Box creation error
	e110	Job accounting clear error	e41a	Box creation error
	e111	Job accounting open error	e41b	Box deletion error
	e112	Job accounting open error	e41c	Box movement error
	e113	Job accounting error in writing	e510	Program error in writing
	e114	Job accounting list error	e511	Program error in reading
	e115	Job accounting list error	e710	Fax memory open error
	e210	One-touch open error	e711	Fax memory initialization error
	e211	One-touch list error	e712	Fax memory list error
	e212	One-touch list error	e713	Fax memory error
	e310	User managements backup error	e714	Fax memory error
	e311	User managements clear error	e715	Fax memory mode error
	e312	User managements open error	e716	Fax memory error
	e313	User managements open error	e717	Fax memory error
	e314	User managements open error	e718	Fax memory mode error
	e315	User managements error in writing	e910	File reading error
	e316	User managements list error	e911	File writing error
	e317	User managements list error	e912	Data mismatch
	e318	User managements list error	e913	Log file open error
	e319	User managements list error	e914	Log file error in writing
	e31a	User managements open error	e915	Directory open error
	e31b	User managements error	e916	Directory error in reading
	e31c	User managements error	e917	Synchronization error
	e31d	User managements open error	e918	Synchronization error

Item No.	Description																																																		
U917	Error Codes																																																		
	<table border="1"> <thead> <tr> <th data-bbox="295 280 414 324">Codes</th> <th data-bbox="414 280 901 324">Description</th> <th data-bbox="901 280 1021 324">Codes</th> <th data-bbox="1021 280 1444 324">Description</th> </tr> </thead> <tbody> <tr> <td>d000</td> <td>Unspecified error</td> <td>d00b</td> <td>File reading error</td> </tr> <tr> <td>d001</td> <td>HDD unavailable</td> <td>d00c</td> <td>File writing error</td> </tr> <tr> <td>d002</td> <td>USB memory is not inserted</td> <td>d00d</td> <td>File copy error</td> </tr> <tr> <td>d003</td> <td>File for writing is not found in the USB</td> <td>d00e</td> <td>File compressed error</td> </tr> <tr> <td>d004</td> <td>File for reading is not found in the HDD</td> <td>d00f</td> <td>File decompressed error</td> </tr> <tr> <td>d005</td> <td>USB error in writing</td> <td>d010</td> <td>Directory open error</td> </tr> <tr> <td>d006</td> <td>USB error in reading</td> <td>d011</td> <td>Directory creation error</td> </tr> <tr> <td>d007</td> <td>USB unmount error</td> <td>d012</td> <td>File writing error</td> </tr> <tr> <td>d008</td> <td>File rename error</td> <td>d013</td> <td>File reading error</td> </tr> <tr> <td>d009</td> <td>File open error</td> <td>d014</td> <td>File deletion error</td> </tr> <tr> <td>d00a</td> <td>File close error</td> <td>d015</td> <td>File copy error to the USB</td> </tr> </tbody> </table>	Codes	Description	Codes	Description	d000	Unspecified error	d00b	File reading error	d001	HDD unavailable	d00c	File writing error	d002	USB memory is not inserted	d00d	File copy error	d003	File for writing is not found in the USB	d00e	File compressed error	d004	File for reading is not found in the HDD	d00f	File decompressed error	d005	USB error in writing	d010	Directory open error	d006	USB error in reading	d011	Directory creation error	d007	USB unmount error	d012	File writing error	d008	File rename error	d013	File reading error	d009	File open error	d014	File deletion error	d00a	File close error	d015	File copy error to the USB		
Codes	Description	Codes	Description																																																
d000	Unspecified error	d00b	File reading error																																																
d001	HDD unavailable	d00c	File writing error																																																
d002	USB memory is not inserted	d00d	File copy error																																																
d003	File for writing is not found in the USB	d00e	File compressed error																																																
d004	File for reading is not found in the HDD	d00f	File decompressed error																																																
d005	USB error in writing	d010	Directory open error																																																
d006	USB error in reading	d011	Directory creation error																																																
d007	USB unmount error	d012	File writing error																																																
d008	File rename error	d013	File reading error																																																
d009	File open error	d014	File deletion error																																																
d00a	File close error	d015	File copy error to the USB																																																
<p>Supplement The following restrictions apply to the data which were imported from 4 in 1 model (with FAX) to 3 in 1 model (without FAX). Personal address book: FAX-related data are not imported. Group address book: Group addresses including FAX addresses are not imported. Job accounting data: Initial values are added for FAX-related data. One-touch data: Groups assigned with FAX addresses or those including FAX are not imported. User management data: Initial values are added for out-going FAXes of authentication. Program data: Not imported. (The same applies when data are imported from 3 in 1 to 4 in 1 model.)</p> <p>Completion Press the stop key. The screen for selecting a maintenance item No. is displayed.</p>																																																			
U927	Clearing the all copy counts and machine life counts (one time only)																																																		
<p>Description Resets all of the counts back to zero.</p> <p>Supplement The total account counter and the machine life counter can be cleared only once if all count values are 1000 or less.</p> <p>Method</p> <ol style="list-style-type: none"> 1. Press the start key. 2. Press [EXECUTE]. 3. Press the start key. All copy counts and machine life counts are cleared. [CAN NOT EXECUTE] is displayed if the count cannot be cleared. <p>Completion Press the stop key. The screen for selecting a maintenance item No. is displayed.</p>																																																			

Item No.	Description
U977	<p data-bbox="287 241 534 275">Data capture mode</p> <p data-bbox="287 313 438 347">Description</p> <p data-bbox="287 347 981 380">Store the print data sent to the machine into USB memory.</p> <p data-bbox="287 380 399 414">Purpose</p> <p data-bbox="287 414 1212 448">In case to occur the error at printing, check the print data sent to the machine.</p> <p data-bbox="287 486 391 519">Method</p> <ol data-bbox="303 519 821 795" style="list-style-type: none">1. Insert USB memory in USB memory slot.2. Turn the power switch on.3. Enter the maintenance item.4. Press the start key.5. Select [EXECUTE].6. Press the start key.7. Send the print data to the machine. <p data-bbox="335 761 1157 795">Once the print data is stored into USB memory, OK will be displayed.</p> <p data-bbox="287 833 438 866">Completion</p> <p data-bbox="287 866 1252 900">Press the stop key. The screen for selecting a maintenance item No. is displayed.</p>

1-3-2 Service mode

The machine is equipped with a maintenance function which can be used to maintain and service the machine.

(1) Executing a service mode

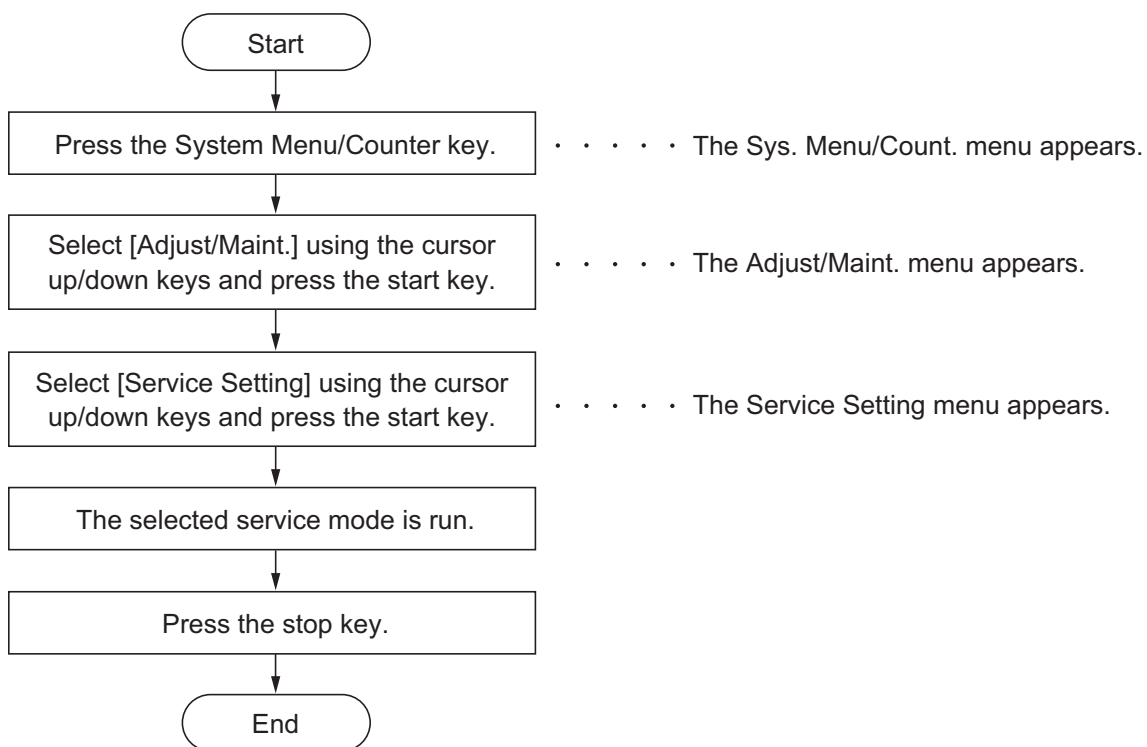

(2) Description of service mode

Service items	Description
Service Status	<p data-bbox="387 297 927 322">Printing a status page for service purpose</p> <p data-bbox="387 365 539 389">Description</p> <p data-bbox="387 398 1422 461">Prints a status page for service purpose. The status page includes various settings and service cumulative.</p> <p data-bbox="387 470 499 495">Purpose</p> <p data-bbox="387 504 1401 528">To acquire the current printing environmental parameters and cumulative information.</p> <p data-bbox="387 571 485 595">Method</p> <ol data-bbox="403 604 1139 739" style="list-style-type: none"> 1. Enter the Service Setting menu. 2. Select [Service Status] using the cursor up/down keys. 3. Press the start key. 4. Press [Yes] (the Left Select key). Two pages will be printed. <p data-bbox="387 781 539 806">Completion</p> <p data-bbox="387 815 616 840">Press the stop key.</p>

Service items	Description																						
	<p data-bbox="387 241 679 275">Service status page (1)</p> <div data-bbox="338 309 1396 1765" style="border: 1px solid black; padding: 10px;"> <h2 data-bbox="363 331 799 376">Service Status Page</h2> <p data-bbox="363 380 421 405">MFP</p> <p data-bbox="1150 376 1342 405">(2) 30/06/2010 12:00</p> <p data-bbox="352 432 829 459">(1) Firmware version 2MH_2000.000.000 2009.08.09</p> <p data-bbox="979 409 1353 459">(3) [XXXXXXXX] (4) [XXXXXXXX] (5) [XXXXXXXX]</p> <hr/> <h3 data-bbox="363 506 651 533">Controller Information</h3> <p data-bbox="395 539 544 562">Memory status</p> <table data-bbox="363 566 699 645"> <tr> <td>(7) Standard Size</td> <td>128.0 KB</td> </tr> <tr> <td>(8) Option Slot</td> <td>128.0 KB</td> </tr> <tr> <td>(9) Total Size</td> <td>256.0 KB</td> </tr> </table> <p data-bbox="874 566 1050 589">(27) FRPO Status</p> <table data-bbox="922 593 1353 645"> <tr> <td>User Top Margin</td> <td>A1+A2/100</td> <td>0.00</td> </tr> <tr> <td>User Left Margin</td> <td>A3+A4/100</td> <td>0.00</td> </tr> </table> <p data-bbox="395 674 448 696">Time</p> <p data-bbox="352 701 730 728">(10) Local Time Zone +01:00 Tokio</p> <p data-bbox="352 730 770 757">(11) Date and Time 06/04/2010 12:00</p> <p data-bbox="352 759 730 786">(12) Time Server 10.183.53.13</p> <p data-bbox="395 813 564 835">Installed Options</p> <p data-bbox="352 840 691 866">(13) Document Processor Installed</p> <p data-bbox="352 869 695 896">(14) Paper Feeder Cassette</p> <p data-bbox="352 898 727 925">(15) Memory Card Not Installed</p> <p data-bbox="352 927 762 954">(16) Card Authentication Kit (B) Installed</p> <p data-bbox="395 981 544 1003">Print Coverage</p> <p data-bbox="352 1008 874 1034">(17) Average(%) / Usage Page(A4/Letter Conversion)</p> <p data-bbox="352 1037 659 1088">(18) Total K: 1.10 / 1111111.11</p> <p data-bbox="352 1090 659 1142">(19) Copy K: 1.10 / 1111111.11</p> <p data-bbox="352 1144 659 1196">(20) Printer K: 1.10 / 1111111.11</p> <p data-bbox="352 1198 659 1249">(21) FAX K: 1.10 / 1111111.11</p> <p data-bbox="352 1252 850 1279">(22) Period (27/10/2009 - 03/11/2009 08:40)</p> <p data-bbox="352 1281 1334 1308">(23) Last Page (%) 1.00 PDF mode Y5 00</p> <p data-bbox="395 1341 555 1364">FAX Information</p> <table data-bbox="352 1368 627 1447"> <tr> <td>(24) Rings (Normal)</td> <td>3</td> </tr> <tr> <td>(25) Rings (FAX/TEL)</td> <td>3</td> </tr> <tr> <td>(26) Rings (TAD)</td> <td>3</td> </tr> </table> <p data-bbox="922 1364 1011 1386">RP Code</p> <table data-bbox="874 1391 1074 1480"> <tr> <td>(28) 1234 5678 9012</td> </tr> <tr> <td>(29) 5678 9012 3456</td> </tr> <tr> <td>(30) 9012 3456 7890</td> </tr> <tr> <td>(31) 3456 7890 1234</td> </tr> </table> <hr/> <p data-bbox="858 1700 1362 1727" style="text-align: right;">1 (6) [XXXXXXXXXXXXXXXXXXXX]</p> </div>	(7) Standard Size	128.0 KB	(8) Option Slot	128.0 KB	(9) Total Size	256.0 KB	User Top Margin	A1+A2/100	0.00	User Left Margin	A3+A4/100	0.00	(24) Rings (Normal)	3	(25) Rings (FAX/TEL)	3	(26) Rings (TAD)	3	(28) 1234 5678 9012	(29) 5678 9012 3456	(30) 9012 3456 7890	(31) 3456 7890 1234
(7) Standard Size	128.0 KB																						
(8) Option Slot	128.0 KB																						
(9) Total Size	256.0 KB																						
User Top Margin	A1+A2/100	0.00																					
User Left Margin	A3+A4/100	0.00																					
(24) Rings (Normal)	3																						
(25) Rings (FAX/TEL)	3																						
(26) Rings (TAD)	3																						
(28) 1234 5678 9012																							
(29) 5678 9012 3456																							
(30) 9012 3456 7890																							
(31) 3456 7890 1234																							

Figure 1-3-4

Service items	Description												
	<p data-bbox="387 241 679 275">Service status page (2)</p> <div data-bbox="338 309 1396 1765" style="border: 1px solid black; padding: 10px;"> <h3 data-bbox="363 331 799 376">Service Status Page</h3> <p data-bbox="363 383 421 407">MFP</p> <p data-bbox="1182 383 1342 407" style="text-align: right;">30/06/2010 12:00</p> <p data-bbox="384 436 1353 461">Firmware version 2MH_2000.000.000 2009.08.09 [XXXXXXXX] [XXXXXXXX] [XXXXXXXX]</p> <hr/> <table border="0" data-bbox="363 504 1305 779"> <tr> <td data-bbox="363 504 612 533">Engine Information</td> <td data-bbox="963 504 1182 533">Send Information</td> </tr> <tr> <td data-bbox="352 539 836 566">(32) NVRAM Version _1F31255_1F31255</td> <td data-bbox="948 539 1305 566">(37) Date and Time 10/06/30</td> </tr> <tr> <td data-bbox="352 568 836 595">(33) Scanner Version 2LX_1200.001.089</td> <td data-bbox="948 568 1066 595">(38) Address</td> </tr> <tr> <td data-bbox="352 598 836 698">(34) FAX Slot1 FAX BOOT Version 2LX_5000.001.001 FAX APL Version 2LX_5100.001.001 FAX IPL Version 2LX_5200.001.001</td> <td></td> </tr> <tr> <td data-bbox="352 701 836 728">(35) MAC Address 00:C0:EE:D0:01:0D</td> <td></td> </tr> <tr> <td data-bbox="352 730 711 779">(36) DP Counters Total 1234</td> <td></td> </tr> </table> <p data-bbox="395 857 525 884">1/2 (39) (40)</p> <p data-bbox="352 887 469 913">(41) 100/100</p> <p data-bbox="352 916 480 943">(42) 0/0/0/0/0/</p> <p data-bbox="352 945 480 972">(43) 0/0/0/0/0/</p> <p data-bbox="352 974 525 1001">(44) 0/0/0/0/0/0/0/</p> <p data-bbox="352 1003 868 1030">(45) 0000000/0000000/0000000/0000000/0000000/0000000/0000000/</p> <p data-bbox="352 1032 1382 1059">F00/U00/0/0/0/30/30/70/00/abcde/1/0 (46) (47) (48) (49) (50) (51) (52) (53) (54) (55) (56) (57) (58)</p> <p data-bbox="352 1061 1102 1088">(59) 0000/0000/0000/0000/0000/0000/0000/0000/0000/0000/0000/0000/0000/0000/0000/0000/</p> <p data-bbox="352 1090 1347 1173">(60) 12345678/11223344/00001234abcd567800001234abcd5678/01234567890123456789012345678901/0008/00/07 2MH_D100.001.005/t/ (61) (62)</p> <p data-bbox="352 1176 663 1202">(63) [ABCDEFGHJI] [ABCDEFGHJI]</p> <p data-bbox="352 1205 528 1232">(64) [ABCDEFGHJI]</p> <p data-bbox="352 1234 1366 1317">(65) 0000000000/F80C001A37/302A183C00/000100013D/8791BEC305/0000003100/000F5D0000/01FD000000/ 0000000FB7/0000000000/0000260000/0000000000/0000000000/0000008400/0000000000/011E000F51/00000073 ABCD/0000000/0000000/ABCDEFGHJI (66) (67) (68) (69)</p> <hr/> <p data-bbox="858 1715 874 1742" style="text-align: center;">2</p> <p data-bbox="1145 1715 1358 1742" style="text-align: right;">[XXXXXXXXXXXXXXXXXXXX]</p> </div>	Engine Information	Send Information	(32) NVRAM Version _1F31255_1F31255	(37) Date and Time 10/06/30	(33) Scanner Version 2LX_1200.001.089	(38) Address	(34) FAX Slot1 FAX BOOT Version 2LX_5000.001.001 FAX APL Version 2LX_5100.001.001 FAX IPL Version 2LX_5200.001.001		(35) MAC Address 00:C0:EE:D0:01:0D		(36) DP Counters Total 1234	
Engine Information	Send Information												
(32) NVRAM Version _1F31255_1F31255	(37) Date and Time 10/06/30												
(33) Scanner Version 2LX_1200.001.089	(38) Address												
(34) FAX Slot1 FAX BOOT Version 2LX_5000.001.001 FAX APL Version 2LX_5100.001.001 FAX IPL Version 2LX_5200.001.001													
(35) MAC Address 00:C0:EE:D0:01:0D													
(36) DP Counters Total 1234													

Figure 1-3-5

Service items	Description	
	Detail of service status page	
	No.	Description
		Supplement
	(1)	Firmware version -
	(2)	System date -
	(3)	Engine soft version -
	(4)	Engine boot version -
	(5)	Operation panel mask version -
	(6)	Machine serial number -
	(7)	Standard memory size -
	(8)	Optional memory size -
	(9)	Total memory size -
	(10)	Local time zone -
	(11)	Report output date -
	(12)	NTP server name -
	(13)	Presence or absence of the document processor -
	(14)	Presence or absence of the optional paper feeder Paper feeder 2/Paper feeder 3
	(15)	Presence or absence of the optional memory card -
	(16)	Presence or absence of the card authentication kit (B) -
	(17)	Page of relation to the A4/Letter -
	(18)	Average coverage for total -
	(19)	Average coverage for copy -
	(20)	Average coverage for printer -
	(21)	Average coverage for fax -
	(22)	Cleared date and output date -
	(23)	Coverage on the final output page -
	(24)	Number of rings 0 to 15
	(25)	Number of rings before auto-automatic switching 0 to 15
	(26)	Number of rings before connecting to answering machine 0 to 15
	(27)	FRPO setting -

Service items	Description																																																				
	<table border="1"> <thead> <tr> <th data-bbox="295 286 379 331">No.</th> <th data-bbox="379 286 798 331">Description</th> <th data-bbox="798 286 1444 331">Supplement</th> </tr> </thead> <tbody> <tr> <td data-bbox="295 331 379 421">(28)</td> <td data-bbox="379 331 798 421">Engine soft version and upgrading date (The latest)</td> <td data-bbox="798 331 1444 421">-</td> </tr> <tr> <td data-bbox="295 421 379 510">(29)</td> <td data-bbox="379 421 798 510">Main soft version and upgrading date (The latest)</td> <td data-bbox="798 421 1444 510">-</td> </tr> <tr> <td data-bbox="295 510 379 600">(30)</td> <td data-bbox="379 510 798 600">Engine soft version and upgrading date (One ahead)</td> <td data-bbox="798 510 1444 600">-</td> </tr> <tr> <td data-bbox="295 600 379 689">(31)</td> <td data-bbox="379 600 798 689">Main soft version and upgrading date (One ahead)</td> <td data-bbox="798 600 1444 689">-</td> </tr> <tr> <td data-bbox="295 689 379 1305">(32)</td> <td data-bbox="379 689 798 1305">NV RAM version</td> <td data-bbox="798 689 1444 1305"> _ 1F3 1225 _ 1F3 1225 (a) (b) (c) (d) (e) (f) (a) Consistency of the present software version and the database _ (underscore): OK * (Asterisk): NG (b) Database version (c) The oldest time stamp of database version (d) Consistency of the present software version and the ME firmware version _ (underscore): OK * (Asterisk): NG (e) ME firmware version (f) The oldest time stamp of the ME database version Normal if (a) and (d) are underscored, and (b) and (e) are identical with (c) and (f). </td> </tr> <tr> <td data-bbox="295 1305 379 1350">(33)</td> <td data-bbox="379 1305 798 1350">Scanner firmware version</td> <td data-bbox="798 1305 1444 1350">-</td> </tr> <tr> <td data-bbox="295 1350 379 1395">(34)</td> <td data-bbox="379 1350 798 1395">Fax firmware version</td> <td data-bbox="798 1350 1444 1395">-</td> </tr> <tr> <td data-bbox="295 1395 379 1440">(35)</td> <td data-bbox="379 1395 798 1440">Mac address</td> <td data-bbox="798 1395 1444 1440">-</td> </tr> <tr> <td data-bbox="295 1440 379 1485">(36)</td> <td data-bbox="379 1440 798 1485">Number of original feed from DP</td> <td data-bbox="798 1440 1444 1485">-</td> </tr> <tr> <td data-bbox="295 1485 379 1529">(37)</td> <td data-bbox="379 1485 798 1529">The last sent date and time</td> <td data-bbox="798 1485 1444 1529">-</td> </tr> <tr> <td data-bbox="295 1529 379 1574">(38)</td> <td data-bbox="379 1529 798 1574">Transmission address</td> <td data-bbox="798 1529 1444 1574">-</td> </tr> <tr> <td data-bbox="295 1574 379 1619">(39)</td> <td data-bbox="379 1574 798 1619">Destination information</td> <td data-bbox="798 1574 1444 1619">-</td> </tr> <tr> <td data-bbox="295 1619 379 1664">(40)</td> <td data-bbox="379 1619 798 1664">Area information</td> <td data-bbox="798 1619 1444 1664">-</td> </tr> <tr> <td data-bbox="295 1664 379 1709">(41)</td> <td data-bbox="379 1664 798 1709">Margin settings</td> <td data-bbox="798 1664 1444 1709">Top margin/Left margin</td> </tr> <tr> <td data-bbox="295 1709 379 1753">(42)</td> <td data-bbox="379 1709 798 1753">Top offset setting</td> <td data-bbox="798 1709 1444 1753">-</td> </tr> <tr> <td data-bbox="295 1753 379 1825">(43)</td> <td data-bbox="379 1753 798 1825">Left offset setting</td> <td data-bbox="798 1753 1444 1825">-</td> </tr> </tbody> </table>	No.	Description	Supplement	(28)	Engine soft version and upgrading date (The latest)	-	(29)	Main soft version and upgrading date (The latest)	-	(30)	Engine soft version and upgrading date (One ahead)	-	(31)	Main soft version and upgrading date (One ahead)	-	(32)	NV RAM version	_ 1F3 1225 _ 1F3 1225 (a) (b) (c) (d) (e) (f) (a) Consistency of the present software version and the database _ (underscore): OK * (Asterisk): NG (b) Database version (c) The oldest time stamp of database version (d) Consistency of the present software version and the ME firmware version _ (underscore): OK * (Asterisk): NG (e) ME firmware version (f) The oldest time stamp of the ME database version Normal if (a) and (d) are underscored, and (b) and (e) are identical with (c) and (f).	(33)	Scanner firmware version	-	(34)	Fax firmware version	-	(35)	Mac address	-	(36)	Number of original feed from DP	-	(37)	The last sent date and time	-	(38)	Transmission address	-	(39)	Destination information	-	(40)	Area information	-	(41)	Margin settings	Top margin/Left margin	(42)	Top offset setting	-	(43)	Left offset setting	-	
No.	Description	Supplement																																																			
(28)	Engine soft version and upgrading date (The latest)	-																																																			
(29)	Main soft version and upgrading date (The latest)	-																																																			
(30)	Engine soft version and upgrading date (One ahead)	-																																																			
(31)	Main soft version and upgrading date (One ahead)	-																																																			
(32)	NV RAM version	_ 1F3 1225 _ 1F3 1225 (a) (b) (c) (d) (e) (f) (a) Consistency of the present software version and the database _ (underscore): OK * (Asterisk): NG (b) Database version (c) The oldest time stamp of database version (d) Consistency of the present software version and the ME firmware version _ (underscore): OK * (Asterisk): NG (e) ME firmware version (f) The oldest time stamp of the ME database version Normal if (a) and (d) are underscored, and (b) and (e) are identical with (c) and (f).																																																			
(33)	Scanner firmware version	-																																																			
(34)	Fax firmware version	-																																																			
(35)	Mac address	-																																																			
(36)	Number of original feed from DP	-																																																			
(37)	The last sent date and time	-																																																			
(38)	Transmission address	-																																																			
(39)	Destination information	-																																																			
(40)	Area information	-																																																			
(41)	Margin settings	Top margin/Left margin																																																			
(42)	Top offset setting	-																																																			
(43)	Left offset setting	-																																																			

Service items	Description		
	No.	Description	Supplement
	(44)	Margin/Page length/Page width settings	Top margin integer part/Top margin decimal part/ Left margin integer part/Left margin decimal part/ Page length integer part/Page length decimal part/ Page width integer part/Page width decimal part
	(45)	Life counter (The first line)	Machine life/MP tray/Cassette 1/Cassette 2/ Cassette 3/Cassette 4 /Duplex
		Life counter (The second line)	Maintenance kit
	(46)	Panel lock information	0: OFF/1: Partial lock/2: Full lock
	(47)	USB information	0: Not installed/1: Full speed/2: Hi speed
	(48)	Paper handling information	0: Paper source unit select/1: Paper source unit
	(49)	Black and white printing double count mode	0: All single counts 3: Folio, Single count, Less than 330 mm (length)
	(50)	Billing counting timing	-
	(51)	Temperature (machine inside)	-
	(52)	Temperature (machine outside)	-
	(53)	Relative temperature (machine outside)	-
	(54)	Absolute temperature (machineoutside)	-
	(55)	LXI calibration information	-
	(56)	Fixed assets number	-
	(57)	Job end judgment time-out time	-
	(58)	Job end detection mode	-
	(59)	Media type attributes 1 to 28 (Not used: 18, 19, 20)	Weight settings 0: Light/1: Normal 1 / 2: Normal 2 / 3: Normal 3/ 4: Heavy 1 / 5: Heavy 2 / 6: Heavy 3 / 7: Extra Heavy Fuser settings 0: High / 1: Middle / 2: Low / 3: Vellum Duplex settings 0: Disable / 1: Enable

Service items	Description																																																								
	<table border="1"> <thead> <tr> <th data-bbox="295 286 383 331">No.</th> <th data-bbox="383 286 798 331">Description</th> <th data-bbox="798 286 1420 331">Supplement</th> </tr> </thead> <tbody> <tr> <td data-bbox="295 331 383 380">(60)</td> <td data-bbox="383 331 798 380">RFID information</td> <td data-bbox="798 331 1420 380">-</td> </tr> <tr> <td data-bbox="295 380 383 465">(61)</td> <td data-bbox="383 380 798 465">RFID reader/writer version information</td> <td data-bbox="798 380 1420 465">-</td> </tr> <tr> <td data-bbox="295 465 383 551">(62)</td> <td data-bbox="383 465 798 551">Toner installation mode information</td> <td data-bbox="798 465 1420 551">-</td> </tr> <tr> <td data-bbox="295 551 383 636">(63)</td> <td data-bbox="383 551 798 636">Soft version of the optional paper feeder</td> <td data-bbox="798 551 1420 636">-</td> </tr> <tr> <td data-bbox="295 636 383 685">(64)</td> <td data-bbox="383 636 798 685">Version of the optional message</td> <td data-bbox="798 636 1420 685">-</td> </tr> <tr> <td data-bbox="295 685 383 734">(65)</td> <td data-bbox="383 685 798 734">Maintenance information</td> <td data-bbox="798 685 1420 734">-</td> </tr> <tr> <td data-bbox="295 734 383 784">(66)</td> <td data-bbox="383 734 798 784">Durm ID</td> <td data-bbox="798 734 1420 784">-</td> </tr> <tr> <td data-bbox="295 784 383 869">(67)</td> <td data-bbox="383 784 798 869">Counter of the developer drive-time</td> <td data-bbox="798 784 1420 869">-</td> </tr> <tr> <td data-bbox="295 869 383 918">(68)</td> <td data-bbox="383 869 798 918">Counter of the drum drive-time</td> <td data-bbox="798 869 1420 918">-</td> </tr> <tr> <td data-bbox="295 918 383 967">(69)</td> <td data-bbox="383 918 798 967">Drum serial number</td> <td data-bbox="798 918 1420 967">-</td> </tr> <tr> <td data-bbox="295 967 383 1137"></td> <td colspan="2" data-bbox="383 967 1420 1137"> Code conversion <table border="1" data-bbox="667 1019 1353 1115"> <tbody> <tr> <td>A</td><td>B</td><td>C</td><td>D</td><td>E</td><td>F</td><td>G</td><td>H</td><td>I</td><td>J</td> </tr> <tr> <td>0</td><td>1</td><td>2</td><td>3</td><td>4</td><td>5</td><td>6</td><td>7</td><td>8</td><td>9</td> </tr> </tbody> </table> </td> </tr> </tbody> </table>	No.	Description	Supplement	(60)	RFID information	-	(61)	RFID reader/writer version information	-	(62)	Toner installation mode information	-	(63)	Soft version of the optional paper feeder	-	(64)	Version of the optional message	-	(65)	Maintenance information	-	(66)	Durm ID	-	(67)	Counter of the developer drive-time	-	(68)	Counter of the drum drive-time	-	(69)	Drum serial number	-		Code conversion <table border="1" data-bbox="667 1019 1353 1115"> <tbody> <tr> <td>A</td><td>B</td><td>C</td><td>D</td><td>E</td><td>F</td><td>G</td><td>H</td><td>I</td><td>J</td> </tr> <tr> <td>0</td><td>1</td><td>2</td><td>3</td><td>4</td><td>5</td><td>6</td><td>7</td><td>8</td><td>9</td> </tr> </tbody> </table>		A	B	C	D	E	F	G	H	I	J	0	1	2	3	4	5	6	7	8	9
No.	Description	Supplement																																																							
(60)	RFID information	-																																																							
(61)	RFID reader/writer version information	-																																																							
(62)	Toner installation mode information	-																																																							
(63)	Soft version of the optional paper feeder	-																																																							
(64)	Version of the optional message	-																																																							
(65)	Maintenance information	-																																																							
(66)	Durm ID	-																																																							
(67)	Counter of the developer drive-time	-																																																							
(68)	Counter of the drum drive-time	-																																																							
(69)	Drum serial number	-																																																							
	Code conversion <table border="1" data-bbox="667 1019 1353 1115"> <tbody> <tr> <td>A</td><td>B</td><td>C</td><td>D</td><td>E</td><td>F</td><td>G</td><td>H</td><td>I</td><td>J</td> </tr> <tr> <td>0</td><td>1</td><td>2</td><td>3</td><td>4</td><td>5</td><td>6</td><td>7</td><td>8</td><td>9</td> </tr> </tbody> </table>		A	B	C	D	E	F	G	H	I	J	0	1	2	3	4	5	6	7	8	9																																			
A	B	C	D	E	F	G	H	I	J																																																
0	1	2	3	4	5	6	7	8	9																																																

Service items	Description
Network Status	<p>Printing a status page for network</p> <p>Description Prints a status page for network.</p> <p>Purpose To acquire the detailed network setting information.</p> <p>Method</p> <ol style="list-style-type: none"> 1. Enter the Service Setting menu. 2. Select [Network Status] using the cursor up/down keys. 3. Press the start key. 4. Press [Yes] in the confirmation display. Network status page will be printed. <p>Completion Press the stop key.</p>
New Developer	<p>Perform the toner installation of the developer unit.</p> <p>Description Perform the toner installation when the developer unit has been replaced.</p> <p>Purpose Perform when the developer unit is replaced.</p> <p>Method</p> <ol style="list-style-type: none"> 1. Enter the Service Setting menu. 2. Select [New Developer] using the cursor up/down keys. 3. Press [Yes] in the confirmation display. <p>Completion Press the stop key.</p>

Service items	Description																																																																												
FAX country code	<p data-bbox="391 241 630 275">FAX Country Code</p> <p data-bbox="391 315 539 342">Description Initializes software switches and all data in the backup data on the FAX control PWB, according to the destination.</p> <p data-bbox="391 421 497 448">Purpose To initialize the FAX control PWB.</p> <p data-bbox="391 524 485 551">Method</p> <ol data-bbox="406 557 1133 757" style="list-style-type: none"> 1. Enter the Service Setting menu. 2. Select [FAX Country Code] using the cursor up/down keys. 3. Press the start key. 4. Enter a destination code using the numeric keys. 5. Press the start key. The setting is set. 6. Press the start key. Data initialization starts. <p data-bbox="391 797 654 824">Destination code list</p> <table border="1" data-bbox="438 840 1388 1751"> <thead> <tr> <th>Code</th> <th>Destination</th> <th>Code</th> <th>Destination</th> </tr> </thead> <tbody> <tr> <td>000</td> <td>Japan</td> <td>253</td> <td>CTR21 (European nations)</td> </tr> <tr> <td>009</td> <td>Australia</td> <td></td> <td>Italy</td> </tr> <tr> <td>038</td> <td>China</td> <td></td> <td>Germany</td> </tr> <tr> <td>080</td> <td>Hong Kong</td> <td></td> <td>Spain</td> </tr> <tr> <td>084</td> <td>Indonesia</td> <td></td> <td>U.K.</td> </tr> <tr> <td>088</td> <td>Israel</td> <td></td> <td>Netherlands</td> </tr> <tr> <td>097</td> <td>Korea</td> <td></td> <td>Sweden</td> </tr> <tr> <td>108</td> <td>Malaysia</td> <td></td> <td>France</td> </tr> <tr> <td>126</td> <td>New Zealand</td> <td></td> <td>Austria</td> </tr> <tr> <td>136</td> <td>Peru</td> <td></td> <td>Switzerland</td> </tr> <tr> <td>137</td> <td>Philippines</td> <td></td> <td>Belgium</td> </tr> <tr> <td>152</td> <td>Middle East</td> <td></td> <td>Denmark</td> </tr> <tr> <td>156</td> <td>Singapore</td> <td></td> <td>Finland</td> </tr> <tr> <td>159</td> <td>South Africa</td> <td></td> <td>Portugal</td> </tr> <tr> <td>169</td> <td>Thailand</td> <td></td> <td>Ireland</td> </tr> <tr> <td>181</td> <td>U.S.A.</td> <td></td> <td>Norway</td> </tr> <tr> <td>242</td> <td>South America</td> <td>254</td> <td>Taiwan</td> </tr> <tr> <td>243</td> <td>Saudi Arabia</td> <td></td> <td></td> </tr> </tbody> </table> <p data-bbox="391 1798 539 1825">Completion Press the stop key.</p>	Code	Destination	Code	Destination	000	Japan	253	CTR21 (European nations)	009	Australia		Italy	038	China		Germany	080	Hong Kong		Spain	084	Indonesia		U.K.	088	Israel		Netherlands	097	Korea		Sweden	108	Malaysia		France	126	New Zealand		Austria	136	Peru		Switzerland	137	Philippines		Belgium	152	Middle East		Denmark	156	Singapore		Finland	159	South Africa		Portugal	169	Thailand		Ireland	181	U.S.A.		Norway	242	South America	254	Taiwan	243	Saudi Arabia		
Code	Destination	Code	Destination																																																																										
000	Japan	253	CTR21 (European nations)																																																																										
009	Australia		Italy																																																																										
038	China		Germany																																																																										
080	Hong Kong		Spain																																																																										
084	Indonesia		U.K.																																																																										
088	Israel		Netherlands																																																																										
097	Korea		Sweden																																																																										
108	Malaysia		France																																																																										
126	New Zealand		Austria																																																																										
136	Peru		Switzerland																																																																										
137	Philippines		Belgium																																																																										
152	Middle East		Denmark																																																																										
156	Singapore		Finland																																																																										
159	South Africa		Portugal																																																																										
169	Thailand		Ireland																																																																										
181	U.S.A.		Norway																																																																										
242	South America	254	Taiwan																																																																										
243	Saudi Arabia																																																																												

Service items	Description								
FAX call Setting	<p>FAX call setting</p> <p>Description Selects if a fax is to be connected to either a PBX or public switched telephone network. Selects the mode to connect an outside call when connected to a PBX. Access code registration for connection to PSTN.</p> <p>Purpose To be executed as required.</p> <p>Method</p> <ol style="list-style-type: none"> 1. Enter the Service Setting menu. 2. Select [FAX Call Set.] using the cursor up/down keys. 3. Press the start key. <table border="1" data-bbox="438 701 1388 896"> <thead> <tr> <th data-bbox="438 701 702 750">Display</th> <th data-bbox="702 701 1388 750">Description</th> </tr> </thead> <tbody> <tr> <td data-bbox="438 750 702 795">Exchange Select.</td> <td data-bbox="702 750 1388 795">Setting the connection to PBX/PSTN</td> </tr> <tr> <td data-bbox="438 795 702 840">PBX Setting</td> <td data-bbox="702 795 1388 840">Setting for a PBX</td> </tr> <tr> <td data-bbox="438 840 702 884">Dial No. to PSTN</td> <td data-bbox="702 840 1388 884">Setting access code to PSTN</td> </tr> </tbody> </table> <p>Setting the connection to PBX/PSTN</p> <ol style="list-style-type: none"> 1. Select [Exchange Select.] using the cursor up/down keys. 2. Press the start key. 3. Select [PBX] or [PSTN] using the cursor up/down keys. 4. Press the start key. The setting is set. <p>Setting for PBX</p> <ol style="list-style-type: none"> 1. Select [PBX Setting] using the cursor up/down keys. 2. Press the start key. 3. Select [Loop], [Flash] or [Earth] using the cursor up/down keys. 4. Press the start key. The setting is set. <p>Setting access code to PSTN</p> <ol style="list-style-type: none"> 1. Select [Dial No. to PSTN] using the cursor up/down keys. 2. Press the start key. 3. Enter access code using the numeric keys. (0 to 9, 00 to 99) 4. Press the start key. The setting is set. <p>Completion Press the stop key.</p>	Display	Description	Exchange Select.	Setting the connection to PBX/PSTN	PBX Setting	Setting for a PBX	Dial No. to PSTN	Setting access code to PSTN
Display	Description								
Exchange Select.	Setting the connection to PBX/PSTN								
PBX Setting	Setting for a PBX								
Dial No. to PSTN	Setting access code to PSTN								

Service items	Description
Remote diagnostics	<p>Setting remote diagnostics</p> <p>Description Sets the remote diagnostics.</p> <p>Purpose Used to establish communication between the machine and the service facility when a problem is encountered.</p> <p>Method</p> <ol style="list-style-type: none"> 1. Enter the Service Setting menu. 2. Select [Remote Diag.Set.] using the cursor up/down keys. 3. Press the start key. 4. Select [On] using the cursor up/down keys. 5. Press the start key. The setting is set. 6. Select [Remote Diag. ID] using the cursor up/down keys. 7. Press the start key. 8. Enter the prespecified remote diagnostics ID number (0000 to 9999) using the numeric keys. 9. Press the start key. The setting is set. <p>Completion Press the stop key.</p>

This page is intentionally left blank.

1-4-1 Paper misfeed detection

(1) Paper misfeed indication

When a paper misfeed occurs, the machine immediately stops printing and displays the paper misfeed message on the operation panel. To remove paper misfed in the machine, pull out the paper cassette, open the front cover, rear cover or duplexer's cover, or remove the drum unit.



Figure 1-4-1 Paper misfeed indication

(2) Paper misfeed detection condition

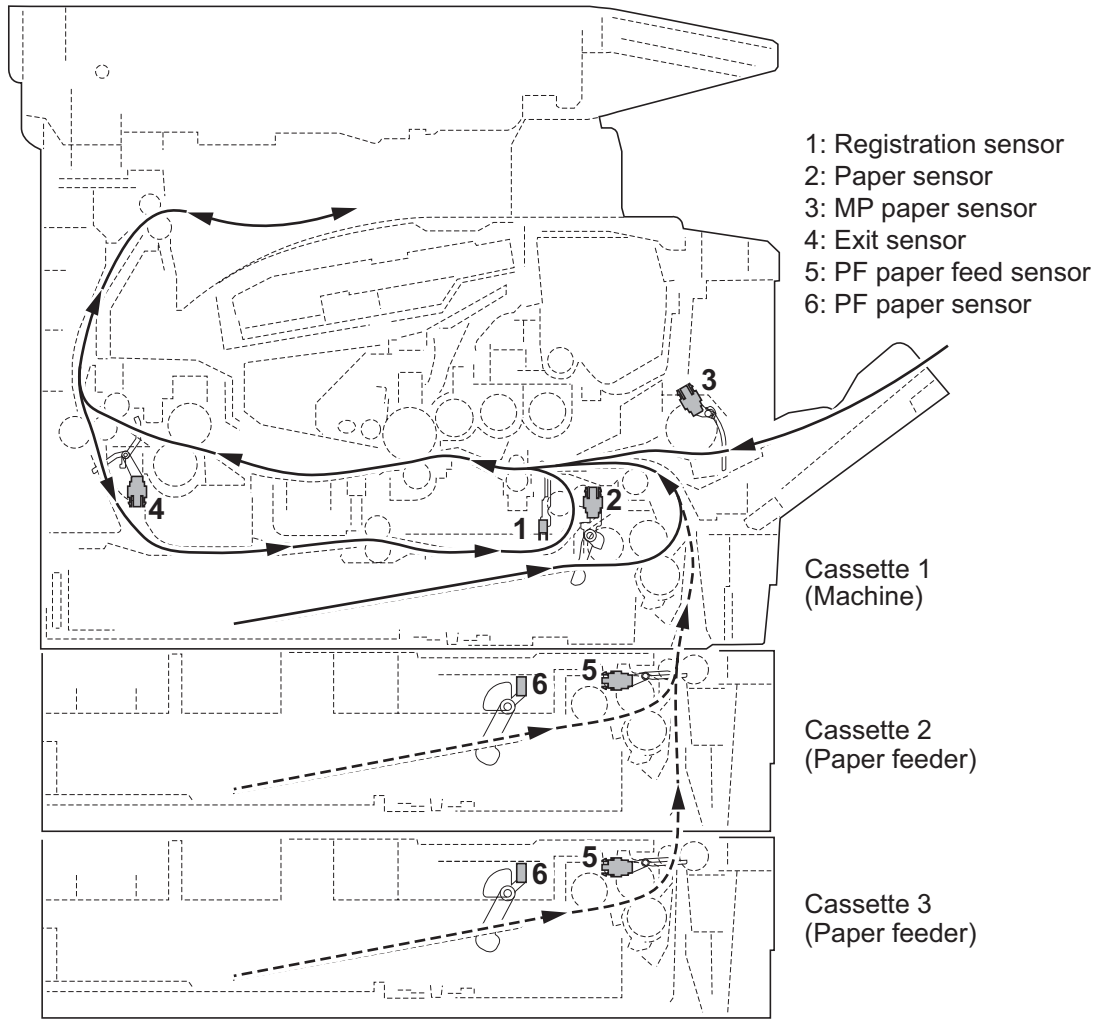
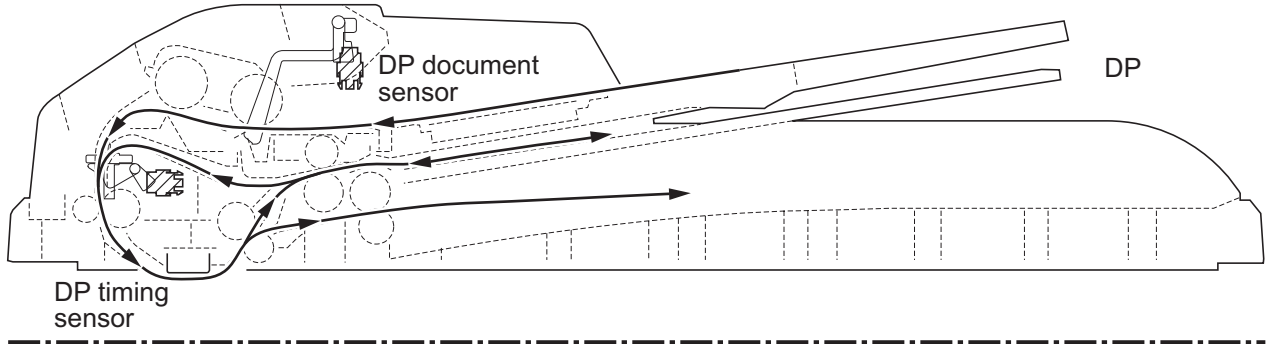

Figure 1-4-2

1-4-2 Self-diagnostic function

(1) Self-diagnostic function

This machine is equipped with self-diagnostic function. When a problem is detected, the machine stops printing and display an error message on the operation panel. An error message consists of a message prompting a contact to service personnel, total print count, and a four-digit error code indicating the type of the error.

(The display varies depending on the type of the error.)

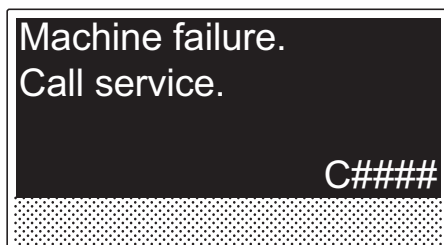

Figure 1-4-3

(2) Self diagnostic codes

Code	Contents	Remarks	
		Causes	Check procedures /corrective measures
0030	FAX control PWB system error Processing with the fax software was disabled due to a hardware problem.	Defective FAX control PWB.	Replace the FAX control PWB (See page 1-5-48).
0070	FAX control PWB incompatible detection Error Abnormal detection of FAX control PWB incompatibility In the initial communication with the FAX control PWB, any normal communication command is not transmitted.	Defective fax software.	Install the fax software.
		Defective FAX control PWB.	Replace the FAX control PWB (See page 1-5-48).
0100	Backup memory device error	Defective flash memory.	Replace the control PWB (See page 1-5-37).
		Defective control PWB.	Replace the control PWB (See page 1-5-37).
0120	MAC address data error	Defective flash memory.	Replace the control PWB (See page 1-5-37).
0130	Backup memory read/write error	Defective flash memory.	Replace the control PWB (See page 1-5-37).
		Defective control PWB.	Replace the control PWB (See page 1-5-37).
0140	Backup memory data error	Defective flash memory.	Replace the control PWB (See page 1-5-37).
		Defective control PWB.	Replace the control PWB (See page 1-5-37).
0150	Control PWB EEPROM error Detecting control PWB EEPROM (U17) communication error.	Improper installation control PWB EEPROM (U17).	Check the installation of the EEPROM (U17) and remedy if necessary (See page 1-5-37).
		Defective control PWB.	Replace the control PWB (See page 1-5-37).
		Data damage of control PWB EEPROM (U17).	Contact the Service Administrative Division.
0170	Billing counting error	Defective control PWB.	Replace the control PWB (See page 1-5-37).
		Data damage of control PWB EEPROM (U17).	Contact the Service Administrative Division.

Code	Contents	Remarks	
		Causes	Check procedures /corrective measures
0180	Machine number mismatch Machine number of main and engine does not match.	The main PWB or the engine PWB were exchanged.	U004 Setting the machine number (See page 1-3-11).
		Data damage of control PWB EEPROM (U17).	Contact the Service Administrative Division.
0420	Paper feeder communication error Communication error between control PWB and optional paper feeder.	Improper installation paper feeder.	Follow installation instruction carefully again.
		Defective harness between control PWB (YC30) and paper feeder interface connector, or improper connector insertion.	Reinsert the connector. Also check for continuity within the connector harness. If none, remedy or replace the harness.
		Defective control PWB.	Replace the control PWB (See page 1-5-37).
		Defective harness between PF main PWB (YC5) and paper feeder interface connector, or improper connector insertion.	Reinsert the connector. Also check for continuity within the connector harness. If none, remedy or replace the harness (Refer to the service manual for the paper feeder).
		Defective PF mainPWB.	Replace the PF main PWB (Refer to the service manual for the paper feeder).
0830	FAX control PWB flash program area checksum error A checksum error occurred with the program of the FAX control PWB.	Defective fax software.	Install the fax software.
		Defective FAX control PWB.	Replace the FAX control PWB (See page 1-5-48).
0840	Faults of RTC The time is judged to go back based on the comparison of the RTC time and the current time or five years or more have passed.	Defective control PWB.	Replace the control PWB (See page 1-5-37).
		The battery is disconnected from the control PWB.	Check visually and remedy if necessary.

Code	Contents	Remarks	
		Causes	Check procedures /corrective measures
0870	FAX control PWB to control PWB high capacity data transfer problem High-capacity data transfer between the FAX control PWB and the control PWB of the machine was not normally performed even if the data transfer was retried the specified times.	Improper installation FAX control PWB.	Reinstall the FAX control PWB (See page 1-5-48).
		Defective FAX control PWB or control PWB.	Replace the FAX control PWB or control PWB and check for correct operation. (See page 1-5-48 or 1-5-37).
0920	Fax file system error The backup data is not retained for file system abnormality of flash memory of the FAX control PWB.	Defective FAX control PWB.	Replace the FAX control PWB (See page 1-5-48).
2000	Main motor error The main motor ready input is not given for 2 s during the main motor is ON.	Defective harness between main motor (CN1) and control PWB (YC17), or improper connector insertion.	Reinsert the connector. Also check for continuity within the connector harness. If none, remedy or replace the harness (See page 1-5-37).
		Defective drive transmission system of the main motor.	Check if the rollers and gears rotate smoothly. If not, grease the bushings and gears. Check for broken gears and replace if any.
		Defective main motor.	Replace the main motor (See page 1-5-49).
		Defective control PWB.	Replace the control PWB (See page 1-5-37).
2610	PF paper feed motor error (paper feeder) The PF paper feed motor of cassette 2 ready input is not given for 2 s during the PF paper feed motor is ON.	Defective harness between PF paper feed motor and PF main PWB (YC4), or improper connector insertion.	Reinsert the connector. Also check for continuity within the connector harness. If none, remedy or replace the harness (Refer to the service manual for the paper feeder).
		Defective PF paper feed motor drive transmission system.	Check if the gears rotate smoothly. If not, grease the bushings and gears. Check for broken gears and replace if any.
		Defective PF main motor.	Replace the PF main motor.
		Defective control PWB.	Replace the control PWB (See page 1-5-37).

Code	Contents	Remarks	
		Causes	Check procedures /corrective measures
2620	PF paper feed motor error (Paper feeder) The PF paper feed motor of cassette 3 ready input is not given for 2 s during the PF paper feed motor is ON.	Defective harness between PF paper feed motor and PF main PWB (YC4), or improper connector insertion.	Reinsert the connector. Also check for continuity within the connector harness. If none, remedy or replace the harness (Refer to the service manual for the paper feeder).
		Defective PF paper feed motor drive transmission system.	Check if the gears rotate smoothly. If not, grease the bushings and gears. Check for broken gears and replace if any.
		Defective PF main motor.	Replace the PF main motor (Refer to the service manual for the paper feeder).
		Defective control PWB.	Replace the control PWB (See page 1-5-37).
3100	ISU home position error	Defective FFC between CCD PWB (YC1) and control PWB (YC8).	Replace the image scanner unit (ISU) (See page 1-5-21).
		Defective FFC between control PWB (YC6) and scanner PWB (YC103), or improper FFC insertion.	Reinsert the FFC. Also check for continuity within the FFC. If none, remedy or replace the FFC.
		Defective home position sensor.	Replace the home position sensor.
		Defective harness between ISU motor and scanner PWB (YC104), or improper connector insertion.	Reinsert the connector. Also check for continuity within the connector harness. If none, remedy or replace the harness.
		Defective ISU motor.	Replace the ISU motor.

Code	Contents	Remarks	
		Causes	Check procedures /corrective measures
3200	Exposure lamp error The exposure lamp is not turned on.	Defective FFC between scanner PWB (YC103) and control PWB (YC6), or improper FFC insertion.	Reinsert the FFC. Also check for continuity within the FFC. If none, remedy or replace the FFC.
		Defective FFC between CCD PWB (YC1) and control PWB (YC8).	Replace the image scanner unit (ISU) (See page 1-5-21).
		Defective harness between CCD PWB (YC3) and LED drive PWB (YC1), or improper connector insertion.	Reinsert the connector. Also check for continuity within the connector harness. If none, remedy or replace the harness.
		Defective harness between LED drive PWB (YC2) and exposure lamp, or improper connector insertion.	Reinsert the connector. Also check for continuity within the connector harness. If none, remedy or replace the harness.
		Defective exposure lamp.	Replace the exposure lamp (See page 1-5-27).
		Defective LED drive PWB.	Replace the LED drive PWB (See page 1-5-27).
		Defective control PWB.	Replace the control PWB (See page 1-5-37).
3300	AGC error After AGC, correct input is not obtained at CCD.	Defective FFC between CCD PWB (YC1) and control PWB (YC8).	Replace the image scanner unit (ISU) (See page 1-5-21).
		Defective exposure lamp.	Replace the exposure lamp (See page 1-5-27).
		Defective CCD PWB.	Replace the CCD PWB.
		Defective control PWB.	Replace the control PWB (See page 1-5-37).

Code	Contents	Remarks	
		Causes	Check procedures /corrective measures
3500	CPU - ASIC (CCD PWB) communication error An error code is detected.	Defective FFC between CCD PWB (YC1) and control PWB (YC8).	Replace the image scanner unit (ISU) (See page 1-5-21).
		Defective CCD PWB.	Replace the CCD PWB.
		Defective control PWB.	Replace the control PWB (See page 1-5-37).
4000	Polygon motor (laser scanner unit) error The polygon motor ready input is not given for 6 s during the polygon motor is ON.	Defective harness between polygon motor and control PWB (YC10), or improper connector insertion.	Reinsert the connector. Also check for continuity within the connector harness. If none, remedy or replace the harness.
		Defective laser scanner unit.	Replace the laser scanner unit (See page 1-5-17).
		Defective control PWB.	Replace the control PWB (See page 1-5-37).
4200	BD error (laser scanner unit) error	BD sensor does not detect laser beam due to condensation on the polygon mirror.	Turn machine power off for at least 30 minutes, then turn machine on again. If not cured, replace the laser scanner unit (See page 1-5-17).
		Defective laser scanner unit.	Replace the laser scanner unit (See page 1-5-17).
		Defective control PWB.	Replace the control PWB (See page 1-5-37).

Code	Contents	Remarks	
		Causes	Check procedures /corrective measures
6000	Broken Fuser heater wire The fuser temperature does not rise after the Fuser heater has been turned on.	Poor contact in the fuser thermistor connector terminals.	Reinsert the connector (See page 1-5-32).
		Poor contact in the Fuser heater connector terminals.	Reinsert the connector (See page 1-5-32).
		Fuser thermistor installed incorrectly.	Replace the fuser unit (See page 1-5-32).
		Fuser thermal cutout triggered.	Replace the fuser unit (See page 1-5-32).
		Fuser heater installed incorrectly.	Replace the fuser unit (See page 1-5-32).
		Broken Fuser heater wire.	Replace the fuser unit (See page 1-5-32).
6020	Abnormally high fuser thermistor temperature Fuser thermistor detects abnormally temperature.	Shorted fuser thermistor.	Replace the fuser unit (See page 1-5-32).
		Defective control PWB.	Replace the control PWB (See page 1-5-37).
6030	Broken fuser thermistor wire Input from fuser thermistor is 0 (A/D value).	Poor contact in the fuser thermistor connector terminals.	Reinsert the connector (See page 1-5-32).
		Broken fuser thermistor wire.	Replace the fuser unit (See page 1-5-32).
		Fuser thermistor installed incorrectly.	Replace the fuser unit (See page 1-5-32).
		Fuser thermal cutout triggered.	Replace the fuser unit (See page 1-5-32).
		Fuser heater installed incorrectly.	Replace the fuser unit (See page 1-5-32).
		Broken Fuser heater wire.	Replace the fuser unit (See page 1-5-32).

Code	Contents	Remarks	
		Causes	Check procedures /corrective measures
6400	Zero cross signal error The zero cross signal does not reach the control PWB for specified time.	Defective harness between high voltage PWB (YC202) and control PWB (YC23), or improper connector insertion.	Reinsert the connector. Also check for continuity within the connector harness. If none, remedy or replace the harness (See page 1-5-37).
		Defective connection between power source PWB (YC103) and high voltage PWB (YC201).	Reinsert the connector.
		Defective power source PWB.	Replace the power source PWB (See page 1-5-40).
		Defective control PWB.	Replace the control PWB (See page 1-5-37).
7990	Waste toner full The waste toner sensor has detected that the waste toner reservoir (drum unit) is full.	Waste toner reservoir (drum unit) is full.	Turn the power switch off/on to restart the machine. If the error is not resolved, replace the drum unit (See page 1-5-28).
		Defective waste toner sensor.	Replace the waste toner sensor.
		Defective control PWB.	Replace the control PWB (See page 1-5-37).

Code	Contents	Remarks	
		Causes	Check procedures /corrective measures
F000	Control PWB - Operation panel PWB communication error	Defective harness between operation panel PWB (YC1) and control PWB (YC7), or improper connector insertion.	Reinsert the connector. Also check for continuity within the connector harness. If none, remedy or replace the harness.
		Defective operation panel PWB.	Replace the operation panel PWB.
		Defective control PWB.	Replace the control PWB (See page 1-5-37).
F020	Control PWB RAM checksum error	Defective main memory (RAM) on the control PWB.	Turn the power switch off/on to restart the machine. If the error is not resolved, replace control PWB (See page 1-5-37).
		Defective expanded memory (DIMM).	Replace the expanded memory (DIMM).
F040	Control PWB engine communication error A communication error is detected.	Defective control PWB.	Turn the power switch off/on to restart the machine. If the error is not resolved, replace control PWB (See page 1-5-37).
F041	Control PWB - scanner PWB communication error A communication error is detected.	Defective control PWB or scanner PWB.	Turn the power switch off/on to restart the machine. If the error is not resolved, replace control PWB or scanner PWB (See page 1-5-37 or 1-5-47).
F050	Control PWB engine checksum error	Some error may have occurred when downloading the firmware of the control PWB.	Download the firmware of the control PWB again (See page 1-6-1).
		Defective control PWB.	Turn the power switch off/on to restart the machine. If the error is not resolved, replace control PWB (See page 1-5-37).
F186	Control PWB video data control error	Defective control PWB.	Turn the power switch off/on to restart the machine. If the error is not resolved, replace control PWB (See page 1-5-37).

1-4-3 Image formation problems

(1) Completely blank printout.

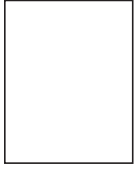

See page 1-4-14

(2) All-black print-out.



See page 1-4-15

(3) Dropouts.

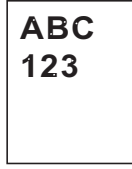

See page 1-4-15

(4) Black dots.

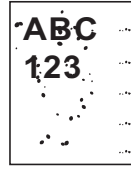

See page 1-4-16

(5) Black horizontal streaks.

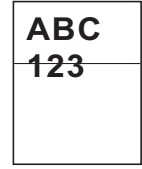

See page 1-4-16

(6) Black vertical streaks.

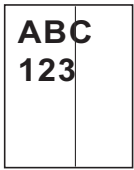

See page 1-4-16

(7) Unsharpness.

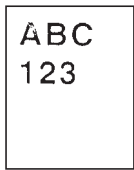

See page 1-4-17

(8) Gray background.

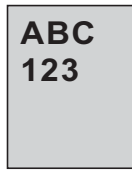

See page 1-4-17

(9) Dirt on the top edge or back of the paper.

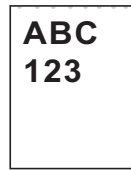

See page 1-4-17

(10) Undulated printing at the right edge (scanning start position).

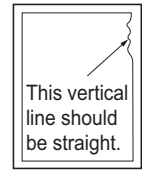

See page 1-4-18

(1) Completely blank printout.

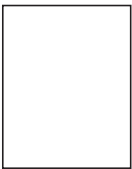
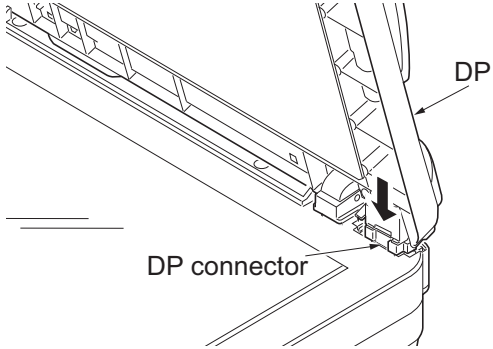
Print example	Causes	Check procedures/corrective measures
	<p>Connection failure with DP connector.</p>	<p>If a blank copy is made because the original loaded in the DP is not fed after the Start key is pressed: Turn the power switch off, investigate the DP connector connection, and firmly connect the DP connector.</p> 
	<p>Defective drum unit or developer unit.</p>	<p>Open the front cover and check that the drum unit and developer unit are correctly seated (See page 1-5-28 and 1-5-27). Investigate that the terminals between the main charger unit and the drum unit are not in loose contact (See page 1-5-28)</p>
	<p>Defective transfer bias output or developer bias output.</p>	<p>Replace the high voltage PWB (See page 1-5-43).</p>
	<p>Poor contact of developer bias terminal (spring) and high voltage output terminal B (J401, J402, J403) on the high voltage PWB. Poor contact of transfer bias terminal (spring) and transfer bias terminal T (J201, J202, J203) on the high voltage PWB.</p>	<p>Check the high voltage PWB visually and correct or replace if necessary (See page 1-5-43).</p>
	<p>Defective laser scanner unit.</p>	<p>Replace the laser scanner unit (See page 1-5-17).</p>
	<p>Defective control PWB.</p>	<p>Replace the control PWB (See page 1-5-37).</p>

(2) All-black printout.

Print example	Causes	Check procedures/corrective measures
	Defective main charger unit.	Open the front cover and check that the drum unit and developer unit are correctly seated (See page 1-5-28 and 1-5-27). Investigate that the terminals between the main charger unit and the drum unit are not in loose contact (See page 1-5-28)
	Poor contact of main charger terminal (spring) and main charger output terminal M on the high voltage PWB.	Check the high voltage PWB visually and correct or replace if necessary (See page 1-5-43).
	Defective main charging output.	Replace the high voltage PWB (See page 1-5-43).
	Broken main charger wire.	Replace the main charger unit (See page 1-5-29).
	Defective control PWB.	Replace the control PWB (See page 1-5-37).

(3) Dropouts.

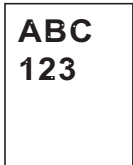
Print example	Causes	Check procedures/corrective measures
	Defective developer roller (developer unit).	If the defects occur at regular intervals of 62.8 mm/2 1/2" (See page 2-4-3), the problem may be the damaged developer roller (in the developer unit). Replace the developer unit (See page 1-5-27).
	Defective drum unit.	If the defects occur at regular intervals of 94 mm/3 11/16" (See page 2-4-3), the problem may be the damaged drum (in the drum unit). Replace the drum unit (See page 1-5-28).
	Defective fuser unit (heat roller or press roller).	If the defects occur at regular intervals of 73.162 mm/ 2 7/8", or 78.5 mm/3 1/16" (See page 2-4-3), the problem may be the damaged heat roller or press roller (in the fuser unit). Replace fuser unit (See page 1-5-32).
	Defective paper specifications.	Paper with rugged surface or dump tends to cause dropouts. Replace paper with the one that satisfies the paper specifications.
	Defective transfer roller installation.	The transfer roller must be supported by the bushes at the both ends. Clean the bush to remove oil and debris. Replace the transfer roller if necessary (See page 1-5-30).
	Defective transfer bias output.	Replace the high voltage PWB or control PWB (See page 1-5-43 or 1-5-37).

(4) Black dots.

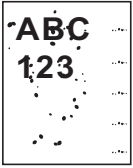
Print example	Causes	Check procedures/corrective measures
	Defective drum unit or developer unit.	If the defects occur at regular intervals of 94 mm/3 11/16" (See page 2-4-3), the problem may be the damaged drum (in the drum unit). Replace drum unit (See page 1-5-28). If the defects occur at random intervals, the toner may be leaking from the developer unit or drum unit. Replace the developer unit or drum unit (See page 1-5-27 or 1-5-28).

(5) Black horizontal streaks.

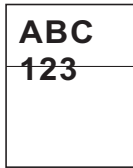
Print example	Causes	Check procedures/corrective measures
	Defective drum unit's ground.	Check that the drum shaft and the grounding tab (machine) are in good contact. Apply the grounding tab a small amount of electroconductive grease as required.
	Defective drum unit.	Replace the drum unit (See page 1-5-28).

(6) Black vertical streaks.

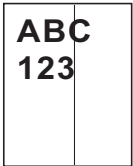
Print example	Causes	Check procedures/corrective measures
	Adhesion of oxide to main charger wire.	Remove the drum unit (See page 1-5-28). Slide the charger cleaner (green) left and right 2 or 3 times to clean the charger wire, then return it to its original position (CLEANER HOME POSITION). Refer to the operation guide.
	Defective drum unit.	A streak of toner remaining on drum after printing means that the cleaning blade (in the drum unit) is not working properly. Replace the drum unit (See page 1-5-28).
	Defective developer roller (developer unit).	Replace the developer unit (See page 1-5-27).

(7) Unsharpness.

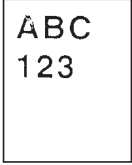
Print example	Causes	Check procedures/corrective measures
	Defective paper specifications.	Replace paper with the one that satisfies the paper specification.
	Defective transfer roller installation.	The transfer roller must be supported by the bushes at the both ends. Clean the bush to remove oil and debris. Replace the transfer roller if necessary (See page 1-5-30).
	Defective transfer bias output.	Replace the high voltage PWB or control PWB (See page 1-5-43 or 1-5-37).
	EcoPrint mode setting.	The EcoPrint mode can provides faint, unsharp printing because it acts to conserve toner for draft printing purpose. For normal printing, turn the EcoPrint mode off by using the operator panel. For details, refer to the operation guide.

(8) Gray background.

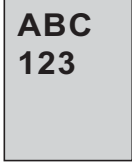
Print example	Causes	Check procedures/corrective measures
	Print density setting.	The print density may be set too high. Try adjusting the print density. For details, refer to the operation guide.
	Defective potential on the drum surface.	Replace the drum unit (See page 1-5-28).
	Defective main charger grid.	Clean the main charger grid (See page 1-5-29).
	Defective developer roller (developer unit).	If a developer unit which is known to work normally is available for check, replace the current developer unit in the machine with the normal one. If the symptom disappears, replace the developer unit with a new one (See page 1-5-27).

(9) Dirt on the top edge or back of the paper.

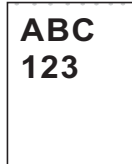
Print example	Causes	Check procedures/corrective measures
	Toner contamination in various parts.	Dirty edges and back of the paper can be caused by toner accumulated on such parts as the paper chute guide, paper conveying paths, the bottom of the drum and developer unit, and the fuser unit inlet. Clean these areas and parts to remove toner.
	Defective transfer roller.	If the transfer roller is contaminated with toner, clean the transfer roller using a vacuum cleaner or by continuously printing a low density page until the symptom has faded away.

(10) Undulated printing at the right edge (scanning start position).

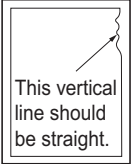
Print example	Causes	Check procedures/corrective measures
 <p>This vertical line should be straight.</p>	Defective polygon motor (laser scanner unit).	Replace the laser scanner unit (See page 1-5-17).
	Defective control PWB.	Replace the control PWB (See page 1-5-37).

1-4-4 Electric problems

Problem	Causes	Check procedures/corrective measures
(1)The machine does not operate when the power switch is turned on.	1. No electricity at the power outlet.	Measure the input voltage.
	2. The power cord is not plugged in properly.	Check the contact between the power plug and the outlet.
	3. The top cover is not closed completely.	Check the top cover.
	4. Broken power cord.	Check for continuity. If none, replace the cord.
	5. Defective power switch.	Check for continuity across the contacts. If none, replace the power source PWB (See page 1-5-40).
	6. Blown fuse in the power source PWB.	Check for continuity. If none, remove the cause of blowing and replace the power source PWB (See page 1-5-40).
	7. Defective interlock switch.	Check for continuity across the contacts of interlock switch. If none, replace the power source PWB (See page 1-5-40).
	8. Defective power source PWB.	Replace the power source PWB (See page 1-5-40).
	9. Defective control PWB.	Replace the control PWB (See page 1-5-37).
(2)Right cooling fan motor does not operate.	1. Broken right cooling fan motor coil.	Check for continuity across the coil. If none, replace the right cooling fan motor.
	2. Defective harness between right cooling fan motor and control PWB (YC27), or improper connector insertion.	Reinsert the connector. Also check for continuity within the connector harness. If none, remedy or replace the harness.
	3. Defective control PWB.	Replace the control PWB (See page 1-5-37).
(3)Left cooling fan motor does not operate.	1. Broken left cooling fan motor coil.	Check for continuity across the coil. If none, replace the left cooling fan motor.
	2. Defective harness between left cooling fan motor and control PWB (YC104), or improper connector insertion.	Reinsert the connector. Also check for continuity within the connector harness. If none, remedy or replace the harness.
	3. Defective control PWB.	Replace the control PWB (See page 1-5-37).

Problem	Causes	Check procedures/corrective measures
(4)Power source fan motor does not operate.	1. Broken power source fan motor coil.	Check for continuity across the coil. If none, replace the power source fan motor.
	2. Defective harness between power source fan motor and control PWB (YC107), or improper connector insertion.	Reinsert the connector. Also check for continuity within the connector harness. If none, remedy or replace the harness.
	3. Defective control PWB.	Replace the control PWB (See page 1-5-37).
(5)Registration clutch does not operate.	1. Broken registration clutch coil.	Check for continuity across the coil. If none, replace the registration clutch.
	2. Defective harness between registration clutch and control PWB (YC20), or improper connector insertion.	Reinsert the connector. Also check for continuity within the connector harness. If none, remedy or replace the harness.
	3. Defective control PWB.	Replace the control PWB (See page 1-5-37).
(6)Paper feed clutch does not operate.	1. Broken paper feed clutch coil.	Check for continuity across the coil. If none, replace the paper feed clutch.
	2. Defective harness between paper feed clutch and control PWB (YC20), or improper connector insertion.	Reinsert the connector. Also check for continuity within the connector harness. If none, remedy or replace the harness.
	3. Defective control PWB.	Replace the control PWB (See page 1-5-37).
(7)Developer clutch does not operate.	1. Broken developer clutch coil.	Check for continuity across the coil. If none, replace the developer clutch.
	2. Defective harness between developer clutch and control PWB (YC20), or improper connector insertion.	Reinsert the connector. Also check for continuity within the connector harness. If none, remedy or replace the harness.
	3. Defective control PWB.	Replace the control PWB (See page 1-5-37).

Problem	Causes	Check procedures/corrective measures
(8)MP paper feed solenoid does not operate.	1. Broken MP paper feed solenoid coil.	Check for continuity across the coil. If none, replace the MP paper feed solenoid.
	2. Defective harness between MP paper feed solenoid and control PWB (YC21), or improper connector insertion.	Reinsert the connector. Also check for continuity within the connector harness. If none, remedy or replace the harness.
	3. Defective control PWB.	Replace the control PWB (See page 1-5-37).
(9)Duplex solenoid does not operate.	1. Broken duplex solenoid coil.	Check for continuity across the coil. If none, replace the duplex solenoid.
	2. Defective harness between duplex solenoid and control PWB (YC29), or improper connector insertion.	Reinsert the connector. Also check for continuity within the connector harness. If none, remedy or replace the harness.
	3. Defective control PWB.	Replace the control PWB (See page 1-5-37).
(10)Cleaning lamp does not turn on.	1. Defective harness between cleaning lamp (YC701) and control PWB (YC28), or improper connector insertion.	Reinsert the connector. Also check for continuity within the connector harness. If none, remedy or replace the harness.
	2. Defective cleaning lamp (PWB).	Replace the cleaning lamp (PWB).
	3. Defective control PWB.	Replace the control PWB (See page 1-5-37).
(11)Paper indicator is flashing when paper is present in the cassette.	1. Defective paper sensor.	Replace the paper sensor.
	2. Defective harness between paper sensor and control PWB (YC18), or improper connector insertion.	Reinsert the connector. Also check for continuity within the connector harness. If none, remedy or replace the harness.

Problem	Causes	Check procedures/corrective measures
(12)A paper jam in the paper feed/ conveying section or fuser section is indicated when the main power switch is turned on.	1. A piece of paper torn from paper is caught around registration sensor or exit sensor.	Check and remove if any.
	2. Defective registration sensor on the high voltage PWB.	Replace the high voltage PWB (See page 1-5-43).
	3. Defective exit sensor.	Replace the exit sensor.
(13)Attention indicator is lit when the front cover is closed.	1. Defective interlock switch on the power source PWB.	Check for continuity across the interlock switch. If there is no continuity when the interlock switch is on, replace the power source PWB (See page 1-5-40).
(14)When the trouble occurs in the DP.		Refer to the DP's service manual.

1-4-5 Mechanical problems

Problem	Causes/check procedures	Corrective measures
(1)No primary paper feed.	Check if the surfaces of the paper feed roller is dirty with paper powder.	Clean with isopropyl alcohol.
	Check if the paper feed roller is deformed.	Check visually and replace any deformed paper feed roller (assembly) (See page 1-5-6).
	Defective paper feed clutch installation.	Check visually and remedy if necessary.
(2)No secondary paper feed.	Check if the surfaces of the upper and lower registration rollers are dirty with paper powder.	Clean with isopropyl alcohol.
	Defective registration clutch installation.	Check visually and remedy if necessary.
(3)Skewed paper feed.	Paper width guide in a cassette installed incorrectly.	Check the paper width guide visually and correct or replace if necessary.
(4)Multiple sheets of paper are fed at one time.	Check if the separator pad or MPF separation pad is worn.	Replace the separator pad if it is worn.
	Check if the paper is curled.	Replace the paper.
(5)Paper jams.	Check if the paper is excessively curled.	Replace the paper.
	Check if the contact between the upper and lower registration rollers is correct.	Check visually and remedy if necessary.
	Check if the heat roller or press roller is extremely dirty or deformed.	Replace the fuser unit (See page 1-5-32).
	Check if the contact between the ejection roller and fuser ejection pulley is correct.	Check visually and remedy if necessary.
(6)Toner drops on the paper conveying path.	Check if the drum unit or developer unit is extremely dirty.	Clean the drum unit or developer unit (See page 1-5-28 or 1-5-27).
(7)Abnormal noise is heard.	Check if the pulleys, rollers and gears operate smoothly.	Grease the bearings and gears.
	Check if the following electromagnetic clutches are installed correctly: Paper feed clutch, registration clutch and developer clutch.	Check visually and remedy if necessary.
(8)When the trouble occurs in the DP.		Refer to the DP's service manual.

1-4-6 Send error code

This section describes the scanning errors and descriptions, preventive actions, as well as corrective actions. Error codes not described here could fall within software errors.

If such an error is encountered, turn power off then on, and advise the service representative.

(1) Scan to SMB error codes

Code	Contents	Check procedures/corrective measures
1101	Host destined does not exist on the network.	<ol style="list-style-type: none"> 1. Confirm the destined host. 2. Confirm the device's network parameters. 3. Confirm the parameters of the network to which the device is connected are correct.
1102	Login to the host has failed.	<ol style="list-style-type: none"> 1. Confirm user name and password. 2. Confirm the parameters of the network to which the device is connected are correct. 3. Check the host if the folder is properly shared.
1103	Destined host, folder, and/or file names are invalid.	<ol style="list-style-type: none"> 1. Check illegal characters are not contained within these names. 2. Check the name of the folder and files conform with the naming syntax. 3. Confirm destined host and folder.
1105	SMB protocol is not enabled.	<ol style="list-style-type: none"> 1. Confirm device's SMB protocols.
2101	Login to the host has failed.	<ol style="list-style-type: none"> 1. Confirm the destined host. 2. Confirm that the LAN cable is properly connected to the device. 3. Check the SMB port number. 4. Confirm the device's network parameters. 5. Confirm the parameters of the network to which the device is connected are correct.
2201	Writing scanned data has failed.	<ol style="list-style-type: none"> 1. Check the file name to save the scanned data. 2. Confirm the device's network parameters. 3. Confirm the parameters of the network to which the device is connected are correct.
2203	No response from the host during a certain period of time.	<ol style="list-style-type: none"> 1. Confirm the network parameters the device is connected. 2. Confirm that the LAN cable is properly connected to the device.

(2) Scan to FTP error codes

Code	Contents	Check procedures/corrective measures
1101	FTP server does not exist on the network.	<ol style="list-style-type: none"> 1. Check the FTP server name. 2. Confirm device's network parameters. 3. Confirm the parameters of the network to which the device is connected are correct.
1102	Login to the FTP server has failed.	<ol style="list-style-type: none"> 1. Confirm user name and password. 2. Check the FTP server name.
1103	Destined folder is invalid.	<ol style="list-style-type: none"> 1. Check that the illegal characters are not contained within these names. 2. Check the FTP server name.
1105	FTP protocol is not enabled.	<ol style="list-style-type: none"> 1. Confirm device's FTP protocols.
1131	Initializing TLS has failed.	<ol style="list-style-type: none"> 1. Confirm device's security parameters.
1132	TLS negotiation has failed.	<ol style="list-style-type: none"> 1. Confirm device's security parameters. 2. Check the FTP server name.
2101	Access to the FTP server has failed.	<ol style="list-style-type: none"> 1. Check the FTP server name. 2. Confirm that the LAN cable is properly connected to the device. 3. Check the FTP port number. 4. Confirm device's network parameters. 5. Confirm the network parameters the device is connected. 6. Check the FTP server name.
2102	Access to the FTP server has failed. (Connection timeout)	<ol style="list-style-type: none"> 1. Check the FTP server name. 2. Check the FTP port number. 3. Confirm device's network parameters. 4. Confirm the network parameters the device is connected. 5. Check the FTP server name.
2103	The server cannot establish communication.	<ol style="list-style-type: none"> 1. Check the FTP server name. 2. Check the FTP port number. 3. Confirm device's network parameters. 4. Confirm the network parameters the device is connected. 5. Check the FTP server name.
2201	Connection with the FTP server has failed.	<ol style="list-style-type: none"> 1. Confirm device's network parameters. 2. Confirm the network parameters the device is connected. 3. Confirm destined folder. 4. Check the FTP server name.
2202	Connection with the FTP server has failed. (Timeout)	<ol style="list-style-type: none"> 1. Confirm device's network parameters. 2. Confirm the network parameters the device is connected.
2203	No response from the server during a certain period of time.	<ol style="list-style-type: none"> 1. Confirm device's network parameters. 2. Confirm the network parameters the device is connected.

Code	Contents	Check procedures/corrective measures
2231	Connection with the FTP server has failed. (FTPS communication)	<ol style="list-style-type: none">1. Confirm device's network parameters.2. Confirm the network parameters the device is connected.
3101	FTP server responded with an error.	<ol style="list-style-type: none">1. Confirm device's network parameters.2. Confirm the network parameters the device is connected.3. Check the FTP server.

(3) Scan to E-mail error codes

Code	Contents	Check procedures/corrective measures
1101	SMTP/POP3 server does not exist on the network.	<ol style="list-style-type: none"> 1. Check the SMTP/POP3 server name. 2. Confirm device's network parameters. 3. Confirm the parameters of the network to which the device is connected are correct.
1102	Login to the SMTP/POP3 server has failed.	<ol style="list-style-type: none"> 1. Confirm user name and password. 2. Check the SMTP/POP3 server.
1104	The domain the destined address belongs is prohibited by scanning restriction.	<ol style="list-style-type: none"> 1. Confirm device's SMTP parameters.
1105	SMTP protocol is not enabled.	<ol style="list-style-type: none"> 1. Confirm device's SMTP protocols.
1106	Sender's address is not specified.	<ol style="list-style-type: none"> 1. Confirm device's SMTP protocols.
2101	Connection to the SMTP/POP3 server has failed.	<ol style="list-style-type: none"> 1. Check the SMTP/POP3 server name. 2. Confirm that the LAN cable is properly connected to the device. 3. Check the SMTP/POP3 port number. 4. Confirm device's network parameters. 5. Confirm the network parameters the device is connected. 6. Check the SMTP/POP3 server.
2102	Connection to the SMTP/POP3 server has failed. (Connection timeout)	<ol style="list-style-type: none"> 1. Check the SMTP/POP3 server name. 2. Check the SMTP/POP3 port number. 3. Confirm device's network parameters. 4. Confirm the network parameters the device is connected. 5. Check the SMTP/POP3 server.
2103	The server cannot establish communication.	<ol style="list-style-type: none"> 1. Check the SMTP/POP3 server name. 2. Check the SMTP/POP3 port number. 3. Confirm device's network parameters. 4. Confirm the network parameters the device is connected. 5. Check the SMTP/POP3 server.
2201	Connection to the SMTP/POP3 server has failed.	<ol style="list-style-type: none"> 1. Confirm device's network parameters. 2. Confirm the network parameters the device is connected.
2202	Connection to the SMTP/POP3 server has failed. (Timeout)	<ol style="list-style-type: none"> 1. Confirm device's network parameters. 2. Confirm the network parameters the device is connected.
2204	The size of scanning exceeded its limit.	<ol style="list-style-type: none"> 1. Confirm device's network parameters.
3101	SMTP/POP3 server responded with an error.	<ol style="list-style-type: none"> 1. Confirm device's network parameters. 2. Confirm the network parameters the device is connected. 3. Check the SMTP/POP3 server.
3201	No SMTP authentication is found.	<ol style="list-style-type: none"> 1. Check the SMTP server. 2. The device supports SMTP authentication services including CRAM-MD5, DIGEST-MD5, PLAIN and LOGIN.

Code	Contents	Check procedures/corrective measures
4803	Failed to establish the SSL session.	<ol style="list-style-type: none"><li data-bbox="782 235 1268 280">1. Verify the self certificate of the device.<li data-bbox="782 280 1380 347">2. Check the server certificate of the SMTP/POP3 server.<li data-bbox="782 347 1428 414">3. Check the SMTP/POP3 configuration of the device and the SMTP/POP3 server.

1-4-7 Error codes

(1) Error code

Error codes are listed on the communication reports, activity report, etc. The codes consist of an error code indication U followed by a 5-digit number. (Error codes for V34 communication errors start with an E indication, followed by five digits.)

The upper three of the five digits indicate general classification of the error and its cause, while the lower two indicate the detailed classification. Items for which detailed classification is not necessary have 00 as the last two digits.

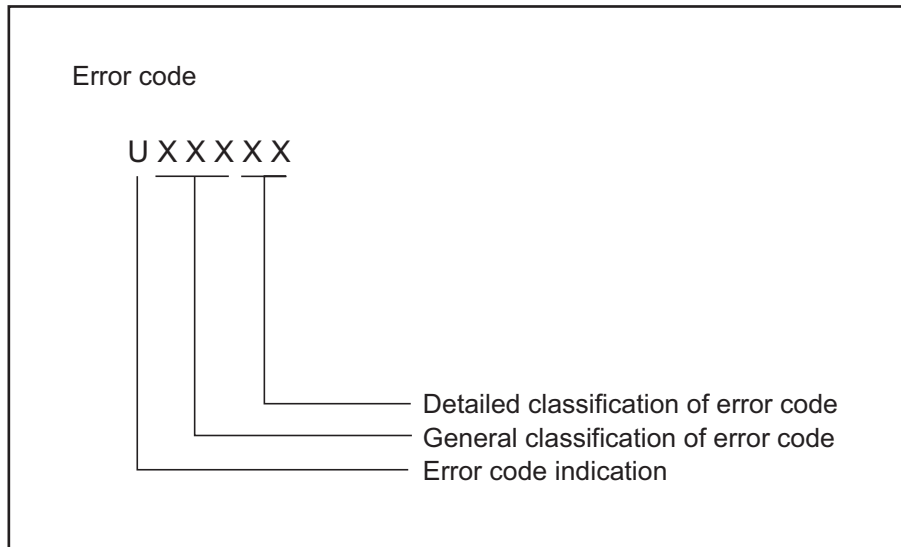

Figure 1-4-4

(2) Table of general classification

Error code	Description
U00000	No response or busy after the set number of redials.
U00100	Transmission was interrupted by a press of the stop/clear key.
U00200	Reception was interrupted by a press of the stop/clear key.
U00300	Recording paper on the destination unit has run out during transmission.
U004XX	A connection was made but interrupted during handshake with the receiver unit (See page 1-4-33).
U00500	Multiple communication was interrupted and call was not made on destination units after interruption.
U006XX	Communication was interrupted because of a machine problem (See page 1-4-34).
U00700	Communication was interrupted because of a problem in the destination unit.
U008XX	A page transmission error occurred in G3 mode (See page 1-4-34).
U009XX	A page reception error occurred in G3 mode (See page 1-4-34).
U010XX	Transmission in G3 mode was interrupted by a signal error (See page 1-4-35).
U011XX	Reception in G3 mode was interrupted by a signal error (See page 1-4-37).
U01400	An invalid one-touch key was specified during communication.
U01500	A communication error occurred when calling in V.8 mode.
U01600	A communication error occurred when called in V.8 mode.
U017XX	A communication error occurred before starting T.30 protocol during transmission in V.34 mode (See page 1-4-38).
U018XX	A communication error occurred before starting T.30 protocol during reception in V.34 mode (See page 1-4-39).
U02000	Relay broadcast was refused by a relay station because of a mismatch in permit ID number and permit telephone number when a relay command was issued.
U02100	A relay command failed because the destination unit (relay station) had no relay broadcast capability.
U02200	A relay command from a command station failed because a telephone number that was not registered in the relay station was specified. Or, relay broadcast was requested to a relay station but failed because a telephone number that was not registered in the relay station was specified. Or, Subaddress-based relay broadcast transmission failed because the data registered in the Subaddress relay box was deleted.
U023XX	Receiving station information was not normally received in reception of a relay command (See page 1-4-39).
U02400	An interoffice subaddress-based relay transmission was interrupted because of a mismatch in the specified relay box number.
U03000	No document was present in the destination unit when polling reception started.
U03100	In reverse polling, although no original was set in the destination unit, transmission was complete.
U03200	In confidential polling reception, data was not accumulated in the specified box in the destination unit. Or, in interoffice subaddress-based bulletin board reception, data was not stored in the box specified by the destination unit.

Error code	Description
U03300	In polling reception from a unit of our make, operation was interrupted due to a mismatch in permit ID or telephone number. Or, in interoffice subaddress-based bulletin board reception, operation was interrupted due to a mismatch in permit ID or telephone number.
U03400	Polling reception was interrupted because of a mismatch in individual numbers (destination unit is either of our make or by another manufacturer).
U03500	In confidential polling reception, the specified confidential box No. was not registered in the destination. Or, in interoffice subaddress-based bulletin board reception, the specified Subaddress confidential box number was not registered in the destination unit. Or, the destination was being accessed.
U03600	Confidential polling reception was interrupted because of a mismatch in specified confidential box No. Or, an interoffice subaddress-based bulletin board reception was interrupted because of a mismatch in the specified subaddress confidential box number.
U03700	Confidential polling reception failed because the destination unit had no confidential polling transmission capability or data was not accumulated in any box in the destination unit. Or, interoffice subaddress-based bulletin board reception failed because the destination unit had no subaddress-based bulletin board transmission capability, or data was not stored in any subaddress confidential box in the destination unit.
U04000	The confidential box specified for confidential transmission was not registered in the destination unit. Or, in interoffice subaddress-based transmission mode, the specified subaddress box number was not registered in the destination unit. Or, the destination was being accessed.
U04100	Confidential transmission failed because the destination unit had no confidential capability. Or, subaddress-based transmission failed because the destination unit had no subaddress-based reception capability.
U04200	In encrypted transmission, the specified encryption box was not registered in the destination unit.
U04300	Encrypted transmission failed because the destination unit had no encrypted communication capability.
U044XX	Communication was interrupted because of an encryption key error during encrypted transmission (See page 1-4-39).
U04500	Encrypted reception was interrupted because of a mismatch in encryption keys.
U05000	In transmission with a specified number, the set number of originals was different from the number of transmitted originals.
U05100	Password check transmission or restricted transmission was interrupted because the permit ID's did not agree with.
U05200	Password check reception or restricted reception was interrupted because the permit ID's did not match, the rejected FAX number's did match, or the destination receiver did not return its phone number.
U05300	The password check reception or the restricted reception was interrupted because the permitted numbers did not match, the rejected numbers did match, or the machine in question did not acknowledge its phone number.
U09000	G3 communication was attempted but failed because the destination unit was a G2 machine.

Error code	Description
U12000	Relay broadcast was requested from a command station but memory overflowed during reception. Or, in subaddress-based relay reception, memory overflowed.
U12100	Relay was commanded but memory overflowed in the destination unit (relay station).
U14000	Memory overflowed during confidential reception. Or, in subaddress-based confidential reception, memory overflowed.
U14100	Memory overflowed in the destination unit during confidential transmission. Or, in interface subaddress-based transmission, memory overflowed in the destination unit.
U19000	Memory overflowed during memory reception.
U19100	Memory overflowed in the destination unit during transmission.
U19200	Memory transmission failed because a decoding error occurred.
U19300	Transmission failed because an error occurred during JBIG encoding.
U19400	Reception failed because an error occurred during JBIG decoding.

(2-1) U004XX error code table: Interrupted phase B

Error code	Description
U00420	A relay request was received from the host center but interrupted because of a mismatch in permit ID or telephone number.
U00421	Subaddress-based relay reception was interrupted because of a mismatch in the specified subaddress relay box number.
U00430	Polling request (confidential or reverse) was received but interrupted because of a mismatch in permit number. Or, subaddress-based bulletin board transmission request was received but interrupted because of a mismatch in permit ID in the transmitting unit.
U00431	Confidential polling transmission was interrupted because the specified confidential box No. was not registered. Or, an subaddress-based bulletin board transmission was interrupted because the specified subaddress confidential box was not registered.
U00432	Confidential polling transmission was interrupted because of a mismatch in confidential box ID number. Or, an subaddress-based bulletin board transmission was interrupted because of a mismatch in Subaddress confidential box numbers.
U00433	Confidential polling request was received but data was not present in the confidential box. Or, subaddress-based bulletin board transmission request was received but data was not present in the subaddress confidential box.
U00434	Confidential polling request was received but interrupted because the specified confidential box No. was intended for encryption.
U00435	Confidential polling request was received but interrupted because the specified confidential box was being accessed. Or, subaddress-based bulletin board transmission request was received but interrupted because the specified subaddress confidential box was being accessed.
U00440	Confidential reception was interrupted because the specified confidential box No. was not registered. Or, subaddress-based confidential reception or subaddress-based relay reception was interrupted because the specified subaddress box was not registered. Or, subaddress based confidential reception or subaddress relay command reception was interrupted because the specified subaddress box No. was being accessed.
U00441	Confidential reception was interrupted because the specified confidential box No. was intended for encryption.
U00450	The destination transmitter disconnected because the permit ID's did not agree with while the destination transmitter is in password-check transmission or restricted transmission.
U00460	Encrypted reception was interrupted because the specified encryption box number was not registered. Or, encrypted reception request was received but interrupted because the specified encryption box was being accessed.
U00462	Encrypted reception was interrupted because the encryption key for the specified encryption box was not registered.

(2-2) U006XX error code table: Problems with the unit

Error code	Description
U00600	The document processor cover is open.
U00601	Document jam or the document length exceeds the maximum.
U00602	Image scanning section problem.
U00603	No document feed.
U00604	Document length exceeded the limit of the bitmap memory capacity.
U00610	Recording section cover is open.
U00611	Recording paper JAM
U00613	Image writing section problem
U00614	Nearly empty of recording paper
U00615	Empty of recording paper
U00620	Copier fixing unit problem
U00622	Copier drive motor problem
U00655	CTS was not activated after RTS due to a modem error.
U00656	Data was not transmitted after CTS was activated due to a modem error.
U00670	Power was cut off during communication.
U00677	There was no file to transmit in the memory transmission mode.
U00690	System error.

(2-3) U008XX error code table: Page transmission error

Error code	Description
U00800	A page transmission error occurred because of reception of a RTN or PIN signal.
U00810	A page transmission error reoccurred after retry of transmission in the ECM mode.

(2-4) U009XX error code table: Page reception error

Error code	Description
U00900	An RTN or PIN signal was transmitted because of a page reception error.
U00910	A page reception error remained after retry of transmission in the ECM mode.

(2-5) U010XX error code table: G3 transmission

Error code	Description
U01000	An FTT signal was received for a set number of times after TCF signal transmission at 2400 bps. Or, an RTN signal was received in response to a Q signal (excluding EOP) after transmission at 2400 bps.
U01001	Function of the unit differs from that indicated by a DIS signal.
U01010	No relevant signal was received after transmission of a DNL (MPS or EOM) signal, and the preset number of command retransfers was exceeded (between units of our make).
U01011	No relevant signal was received after transmission of a DCS, TCF signal, and the preset number of command retransfers was exceeded.
U01012	No relevant signal was received after transmission of an NSS1, NSS2 (TCF) signal, and the preset number of command retransfers was exceeded (between units of our make).
U01013	No relevant signal was received after transmission of an NSS3, TCF signal, and the preset number of command retransfers was exceeded (between units of our make).
U01014	No relevant signal was received after transmission of an MPS signal, and the preset number of command retransfers was exceeded.
U01015	No relevant signal was received after transmission of an EOM signal, and the preset number of command retransfers was exceeded.
U01016	An MCF signal was received but no DIS signal was received after transmission of an EOM signal, and T1 timeout was detected.
U01017	No relevant signal was received after transmission of an EOP signal, and the preset number of command retransfers was exceeded.
U01018	No relevant signal was received after transmission of a PRI-EOP signal, and the preset number of command retransfers was exceeded.
U01019	No relevant signal was received after transmission of a CNC signal, and the preset number of command retransfers was exceeded (between units of our make).
U01020	No relevant signal was received after transmission of a CTC signal, and the preset number of command retransfers was exceeded (ECM).
U01021	No relevant signal was received after transmission of an EOR.Q signal, and the preset number of command retransfers was exceeded (ECM).
U01022	No relevant signal was received after transmission of an RR signal, and the preset number of command retransfers was exceeded (ECM).
U01023	No relevant signal was received after transmission of a PSS.NULL signal, and the preset number of command retransfers was exceeded (ECM).
U01024	No relevant signal was received after transmission of a PSS.MPS signal, and the preset number of command retransfers was exceeded (ECM).
U01025	No relevant signal was received after transmission of a PPS.EOM signal, and the preset number of command retransfers was exceeded (ECM).
U01026	No relevant signal was received after transmission of a PPS.EOP signal, and the preset number of command retransfers was exceeded (ECM).
U01027	No relevant signal was received after transmission of a PPS.PRI-EOP signal, and the preset number of command retransfers was exceeded (ECM).
U01028	T5 time-out was detected during ECM transmission (ECM).

Error code	Description
U01040	A DCN or other inappropriate signal was received during standby for DIS signal reception.
U01041	A DCN signal was received after transmission of a DNL (MPS or EOM) signal (between units of our make).
U01042	A DCN signal was received after transmission of a DCS, TCF signal.
U01043	A DCN signal was received after transmission of an NSS1, NSS2 (TCF) signal (between units of our make).
U01044	A DCN signal was received after transmission of an NSS3, TCF signal (between units of our make).
U01045	A DCN or other inappropriate signal was received after transmission of an MPS signal.
U01046	A DCN or other inappropriate signal was received after transmission of an EOM signal.
U01047	A DCN or other inappropriate signal was received after transmission of an EOP signal.
U01048	A DCN signal was received after transmission of a PRI-EOP signal.
U01049	A DCN signal was received after transmission of a CNC signal (between units of our make).
U01050	A DCN signal was received after transmission of a CTC signal (ECM).
U01051	A DCN signal was received after transmission of an EOR.Q signal (ECM).
U01052	A DCN signal was received after transmission of an RR signal (ECM).
U01053	A DCN signal was received after transmission of a PPS.NULL signal (ECM).
U01054	A DCN signal was received after transmission of a PPS.MPS signal (ECM).
U01055	A DCN signal was received after transmission of a PPS.EOM signal (ECM).
U01056	A DCN signal was received after transmission of a PPS.EOP signal (ECM).
U01057	A DCN signal was received after transmission of a PPS.PRI-EOP signal (ECM).
U01070	Polarity reversal was detected during handshake.
U01071	Polarity reversal was detected during message transmission.
U01072	A break in loop current was detected during transmission.
U01073	During reverse polling in V.34 mode at the receiver unit, a CM signal was not detected when transmitting after reception.
U01080	A PIP signal was received after transmission of a PPS.NULL signal.
U01091	During transmission in V.34 mode, communication was interrupted because a PPR signal was received over 10 times even after reducing the communication speed to the minimum with the symbol speed maintained at the level of connection.
U01092	During transmission in V.34 mode, communication was interrupted because of an impossible combination of the symbol speed and communication speed.

(2-6) U011XX error code table: G3 reception

Error code	Description
U01100	Function of the unit differs from that indicated by a DCS signal.
U01101	Function of the unit (excl. communication mode select) differs from that indicated by an NSS signal.
U01102	A DTC (NSC) signal was received when no transmission data was in the unit.
U01110	No response after transmission of a DIS signal.
U01111	No response after transmission of a DTC (NSC) signal.
U01112	No training reception after reception of a DCS or NSS signal.
U01113	No response after transmission of an FTT signal.
U01114	No message reception after transmission of a CFR signal.
U01115	No message reception after transmission of an MCF signal.
U01116	No message reception after transmission of a PPR signal.
U01117	No message reception after transmission of a CTR signal.
U01118	No message reception after transmission of an ERR signal.
U01119	No further signals were received after reception of a message.
U01120	No response after transmission of an MCF signal.
U01121	No response after transmission of an RTP signal.
U01122	No response after transmission of an RTN signal.
U01123	No response after transmission of a PIP signal.
U01124	No response after transmission of a PIN signal.
U01125	No response after transmission of a CNS signal (between units of our make).
U01126	No response after transmission of a PPR signal (ECM).
U01127	No response after transmission of an ERR signal (ECM).
U01128	No response after transmission of an RNR signal (ECM).
U01129	No response after transmission of an SPA signal (short protocol).
U01140	A DCN signal was received after transmission of a DIS signal.
U01141	A DCN signal was received after transmission of a DTC signal.
U01142	A DCN signal was received after transmission of a DCS or NSS signal.
U01143	A DCN signal was received after transmission of an FTT signal.
U01144	A DCN signal was received after transmission of a CFR signal.
U01145	A DCN signal was received after reception of a message.
U01146	A DCN signal was received after transmission of an MCF signal (interoffice communication after reception of an MPS, EOM signal or confidential interoffice communication).
U01147	A DCN signal was received after transmission of an RTP signal.
U01148	A DCN signal was received after transmission of an RTN signal.
U01149	A DCN signal was received after transmission of a PIP signal.
U01150	A DCN signal was received after transmission of a PIN signal.
U01151	A DCN signal was received after transmission of a PPR signal (ECM).

Error code	Description
U01152	A DCN signal was received after transmission of a CTR signal (ECM).
U01153	A DCN signal was received after transmission of an ERR signal (ECM).
U01154	A DCN signal was received after transmission of an RNR signal (ECM).
U01155	A DCN signal was received after transmission of an SPA signal (short protocol).
U01160	During message reception, transmission time exceeded the maximum transmission time per line.
U01161	Number of error lines exceeded limits during message reception.
U01162	A break in loop current was detected during message reception.
U01163	Polarity reversal was detected during message reception.
U01164	One page length exceeded the specified length during message reception.
U01170	A decoding error occurred during MMR message reception.
U01172	During reverse polling in V.34 mode at the transmitting unit, a JM signal was not detected after transmission of a CM signal when receiving after transmission.
U01191	Communication was interrupted because an error occurred during an image data reception sequence in the V.34 mode.
U01199	A DIS signal with different FIF was received after transmission of a DIS signal.

(2-7) U017XX error code table: V.34 transmission

Error code	Description
U01700	A communication error occurred in phase 2 (line probing).
U01720	A communication error occurred in phase 4 (modem parameter exchange).
U01721	Operation was interrupted due to the absence of a common communication speed between units.

U01700: A communication error that occurs at the transmitting unit in the period after transmission of INFO0 before entering phase 3 (primary channel equivalent device training). For example, INFO0/A/Abar (B/Bbar, for polling transmission)/INFOh was not detected.

U01720: A communication error that occurs at the transmitting unit in the period after initiating the control channel before entering the T.30 process. For example, PPh/ALT/MPh/E was not detected.

U01721: In the absence of a common communication speed between units (including when an impossible combination of communication speed and symbol speed occurs) after MPh exchange; 1) a DCN signal was received from the destination unit, and the line was cut; or 2) a DIS (NSF, CSI) signal was received from the destination unit and, in response to the signal, the unit transmitted a DCN signal, and the line was cut.

(2-8) U018XX error code table: V.34 reception

Error code	Description
U01800	A communication error occurred in phase 2 (line probing).
U01810	A communication error occurred in phase 3 (primary channel equivalent device training).
U01820	A communication error occurred in phase 4 (modem parameter exchange).
U01821	Operation was interrupted due to the absence of a common communication speed between units.

U01800: A communication error that occurs at the receiver unit in the period after transmission of INFO0 before entering phase 3 (primary channel equivalent device training). For example, INFO0/B/Bbar (A/Abar, for polling reception)/probing tone was not detected.

U01810: A communication error that occurs at the receiver unit in phase 3 (primary channel equivalent device training).

For example, S/Sbar/PP/TRN was not detected.

U01820: A communication error that occurs at the receiver unit in the period after initiating the control channel before entering the T.30 process. For example, PPh/ALT/MPh/E was not detected.

U01821: In the absence of a common communication speed between units (including when an impossible combination of communication speed and symbol speed occurs) after MPh exchange, a DCN signal was transmitted to the destination unit and the line was cut.

(2-9) U023XX error code table: Relay command abnormal reception

Error code	Description
U02303	Timeout was detected before a correct DNL signal was received.
U02304	A signal other than MPS or EOM signal was received after a DNL signal was received.

(2-10) U044XX error code table: Encrypted transmission

Error code	Description
U04400	Encrypted transmission was interrupted because encryption keys did not agree.
U04401	Calling failed during encrypted transmission because the encryption key was not registered.

This page is intentionally left blank.

1-5-1 Precautions for assembly and disassembly

(1) Precautions

Before starting disassembly, press the Power key on the operation panel to off. Make sure that the Power lamp is off before turning off the power switch. Unplug the power cable from the wall outlet.

When the fax kit is installed, be sure to disconnect the modular code before starting disassembly.

When handling PWBs (printed wiring boards), do not touch parts with bare hands.

The PWBs are susceptible to static charge.

Do not touch any PWB containing ICs with bare hands or any object prone to static charge.

When removing the hook of the connector, be sure to release the hook.

Take care not to get the cables caught.

To reassemble the parts, use the original screws. If the types and the sizes of screws are not known, refer to the PARTS LIST.

(2) Drum unit

Note the following when handling or storing the drum unit.

When removing the drum unit, never expose the drum surface to strong direct light.

Do not leave it for a long time even if it is weak light such as fluorescent lamps.

Keep the drum unit at an ambient temperature between -20°C/-4°F and 40°C/104°F and at a relative humidity not higher than 85% RH. Avoid abrupt changes in temperature and humidity.

Avoid exposure to any substance which is harmful to or may affect the quality of the drum unit.

Do not touch the drum surface with any object. Should it be touched by hands or stained with oil, clean it.

(3) Toner

Store the toner container in a cool, dark place.

Avoid direct light and high humidity.

(4) How to tell a genuine Kyocera Mita toner container

As a means of brand protection, the Kyocera Mita toner container utilizes an optical security technology to enable visual validation. A validation viewer is required to accomplish this.

Hold the validation viewer over the left side part of the brand protection seal on the toner container. Through each window of the validation viewer, the left side part of the seal should be seen as follows:

A black-colored band when seen through the left side window (●)

A shiny or gold-colored band when seen through the right side window (☀)

The above will reveal that the toner container is a genuine Kyocera Mita branded toner container, otherwise, it is a counterfeit.

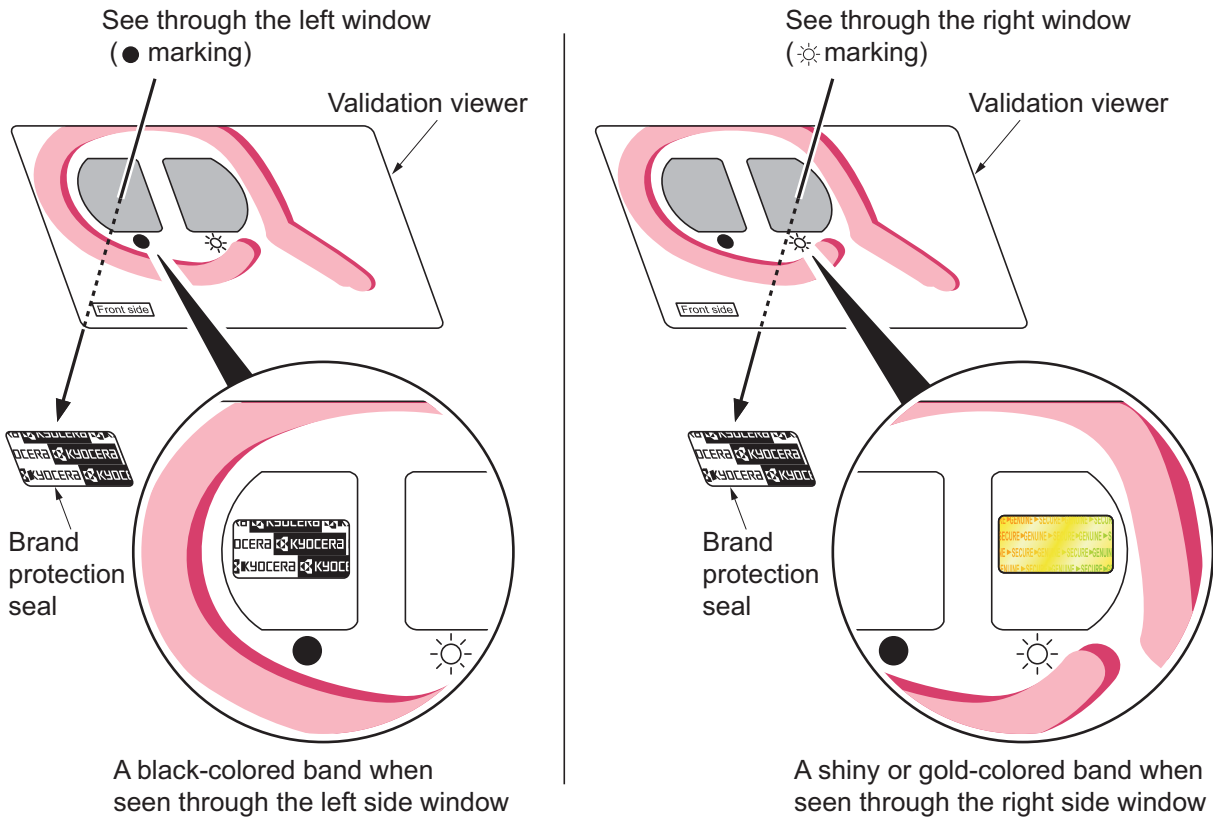

Figure 1-5-1

The brand protection seal has an incision as shown below to prohibit reuse.

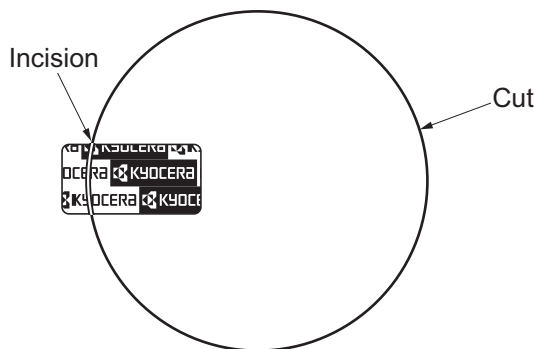

Figure 1-5-2

1-5-2 Outer covers

(1) Detaching and refitting the left cover and right cover

Procedure

1. Remove the screw.
2. Unhook four hooks and then remove the rear upper cover.

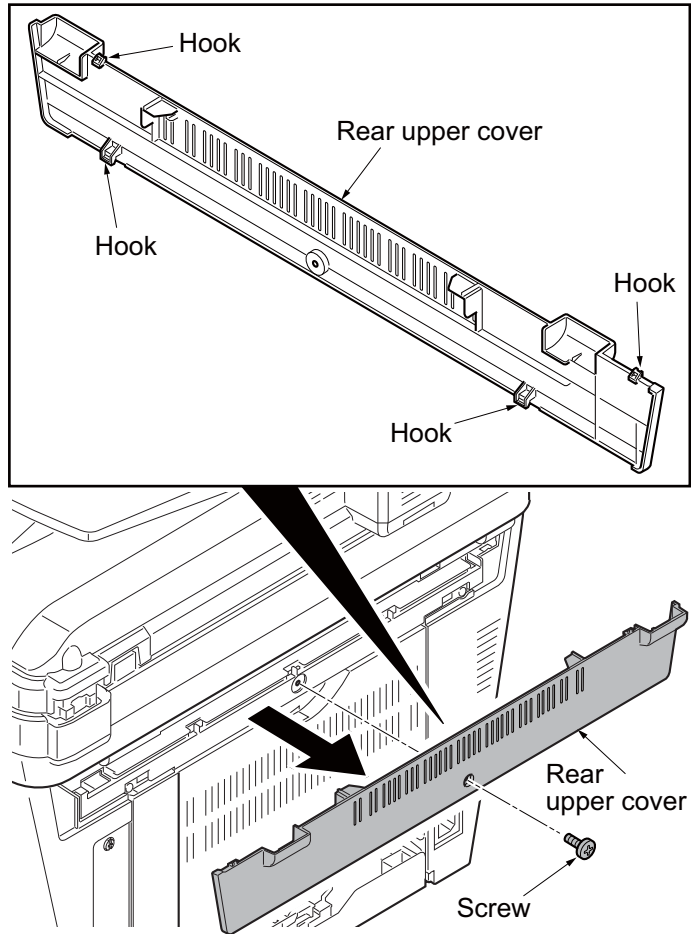

Figure 1-5-3

3. Remove the cassette
(See page 1-5-6).
4. Open the front cover.
5. Unhook the hook and then remove the controller box cover.

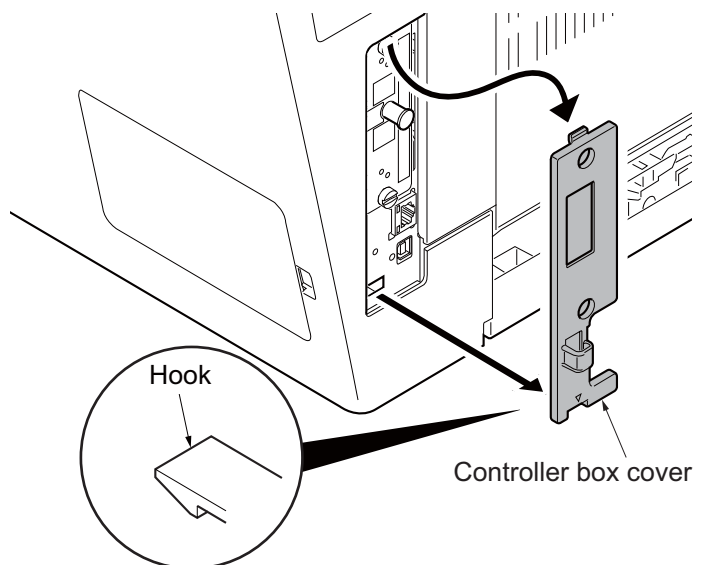

Figure 1-5-4

6. Unhook seven hooks and then remove the right cover.

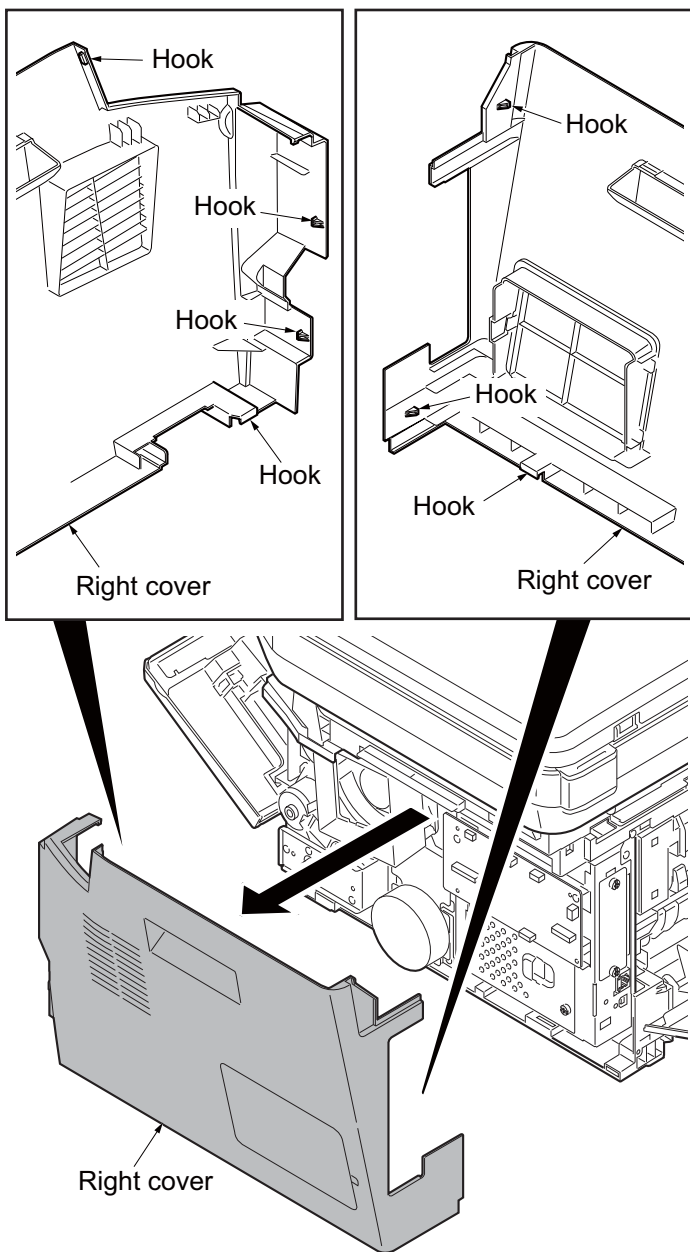

Figure 1-5-5

7. Unhook six hooks and then remove the left cover.

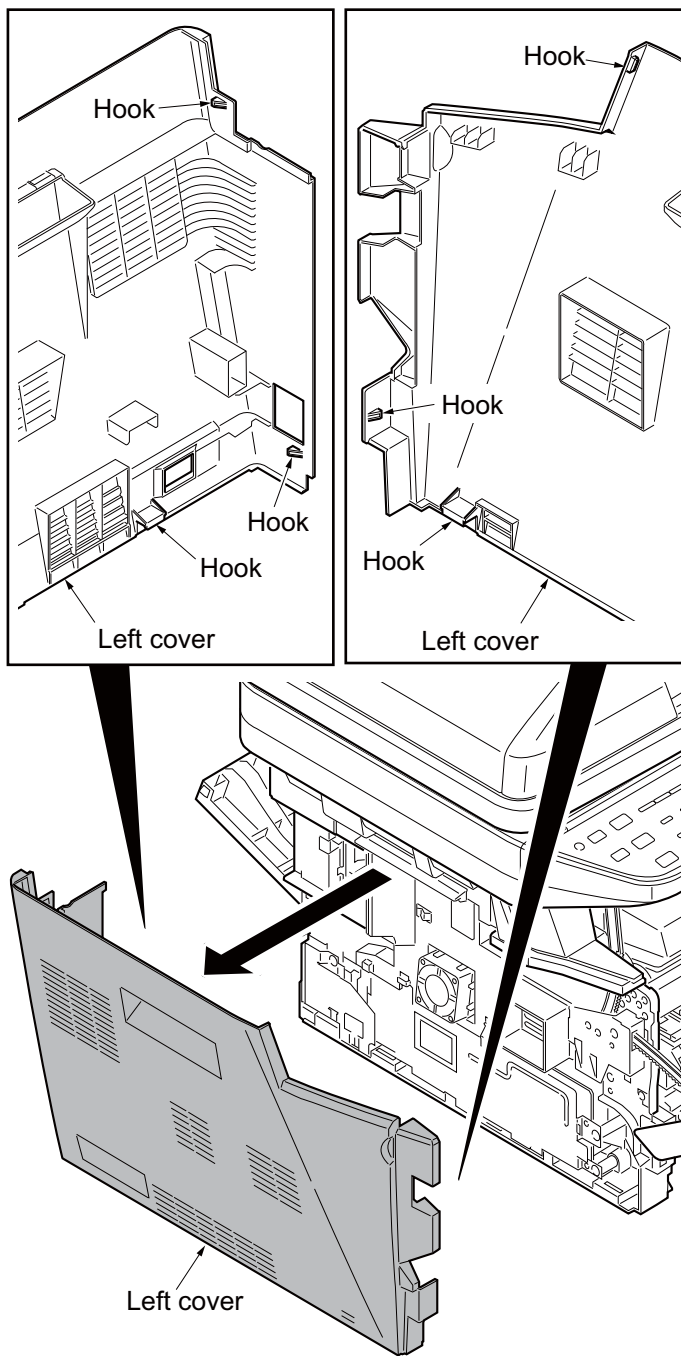

Figure 1-5-6

1-5-3 Paper feed section

(1) Detaching and refitting the paper feed assembly (paper feed roller and pickup roller)

Procedure

1. Remove the cassette.

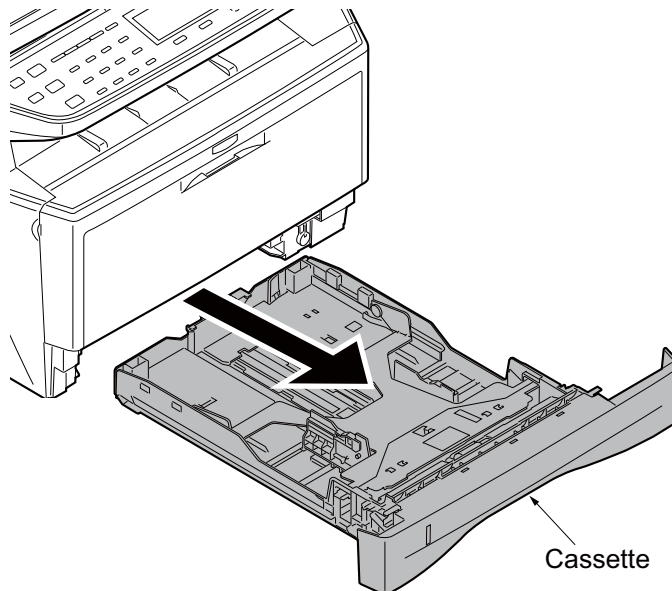

Figure 1-5-7

2. Slide the feed shaft.
3. While pressing the lever and then remove the paper feed roller assembly.

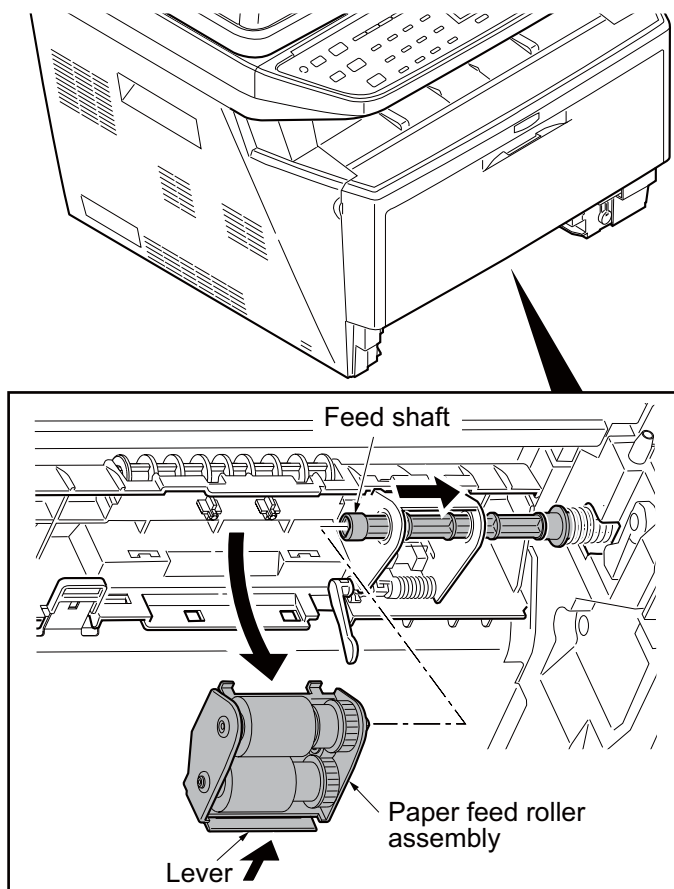

Figure 1-5-8

4. Check or replace the paper feed roller assembly and refit all the removed parts.

When refitting the paper feed roller assembly, be sure to align the paper feed roller pivot with the slotted hole on the feed shaft.

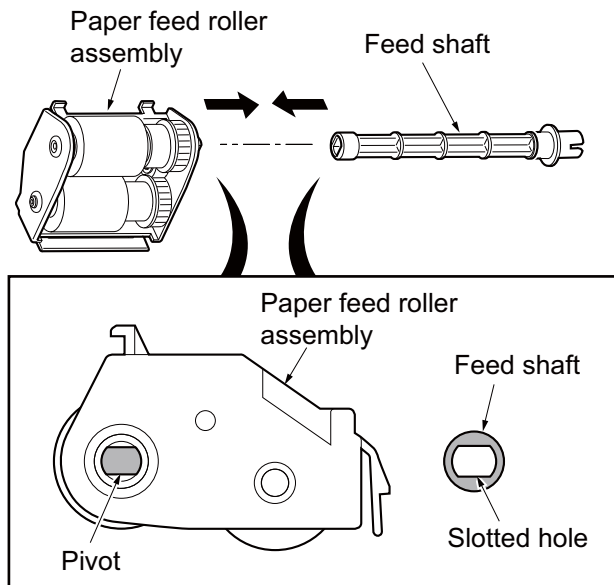

Figure 1-5-9

(2) Detaching and refitting the retard roller assembly

Procedure

1. Remove the cassette (See page 1-5-6).
2. Push the bottom plate down until it locks.
3. Unhook two hooks and then remove the retard guide.

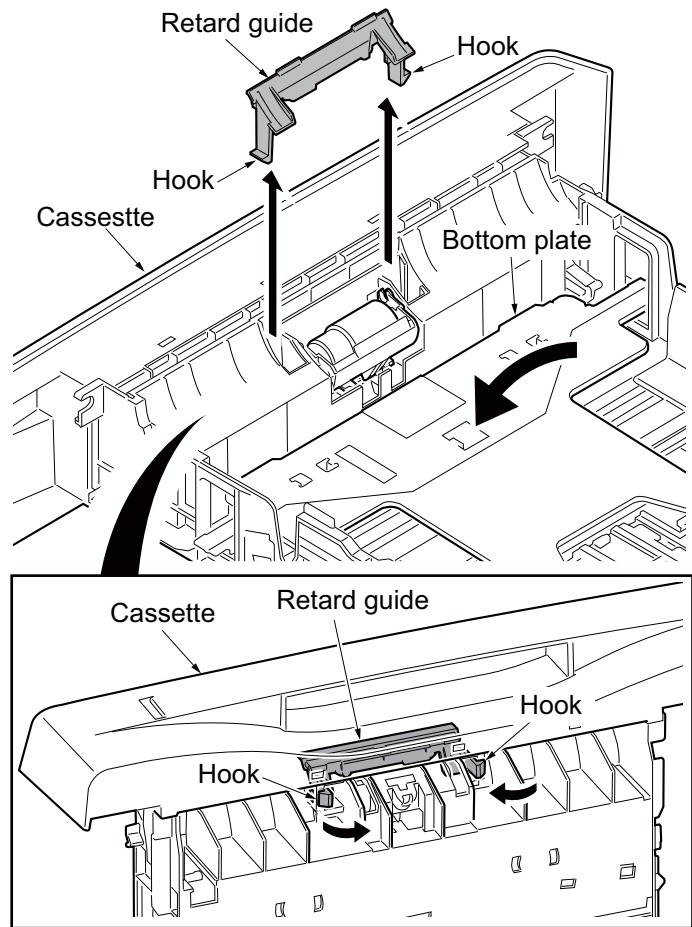

Figure 1-5-10

4. Remove the retard roller assembly.

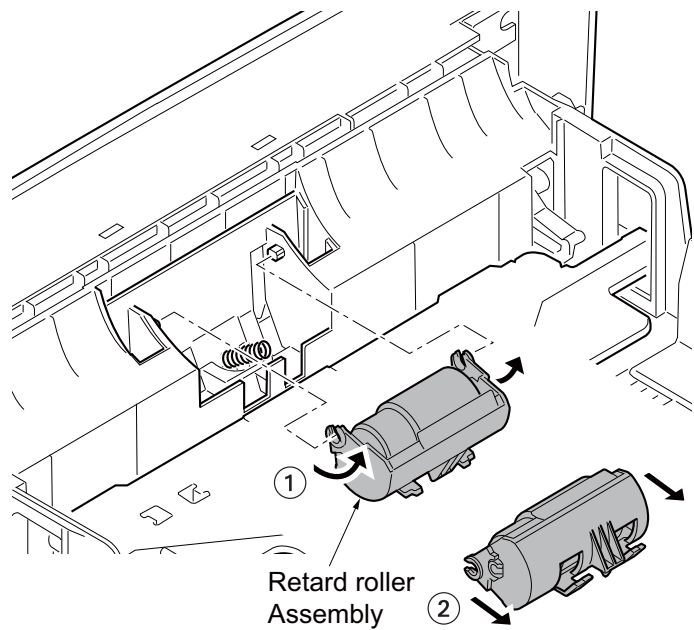

Figure 1-5-11

- 5. Check or replace the retard roller assembly and refit all the removed parts.

Caution: Before refitting the retard roller assembly, firmly install the spring onto the projection of the retard roller assembly.

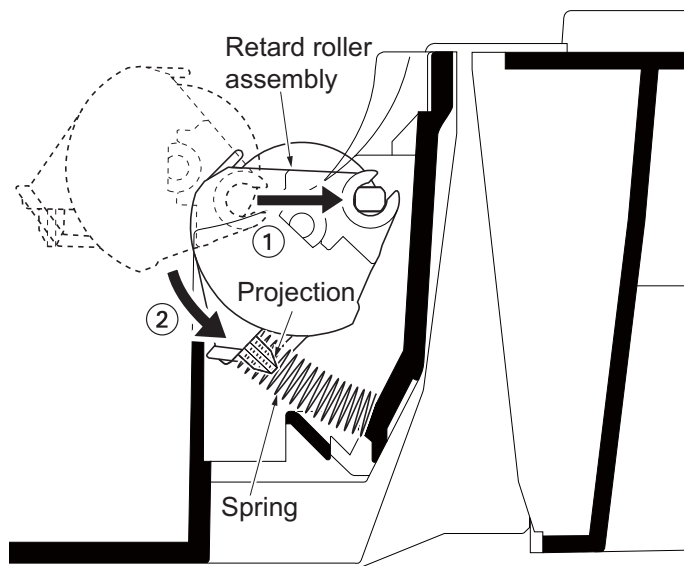

Figure 1-5-12

(3) Detaching and refitting the MP paper feed roller

Procedure

1. Open the front cover.
2. Pull the MP feed holder (lever) down. :1
3. Slide the MP feed holder. :2
4. Remove the MP paper feed roller. :3

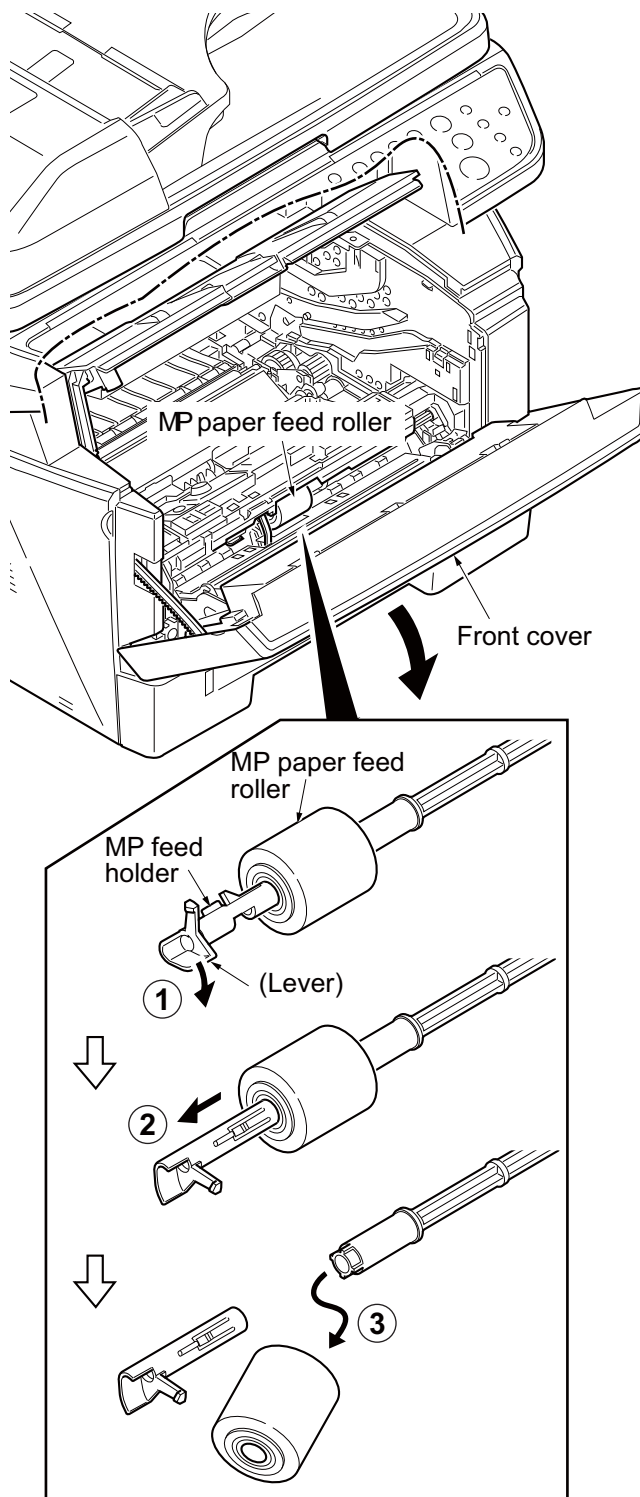

Figure 1-5-13

- 5. Check or replace the MP paper feed roller and refit all the removed parts.

When refitting the MP paper feed roller, be sure to align the paper feed roller pivot with the slotted hole on the MPF feed shaft.

When refitting the MP paper feed roller, be sure to align the MPF feed shaft pivot with the slotted hole on the MP paper feed roller.

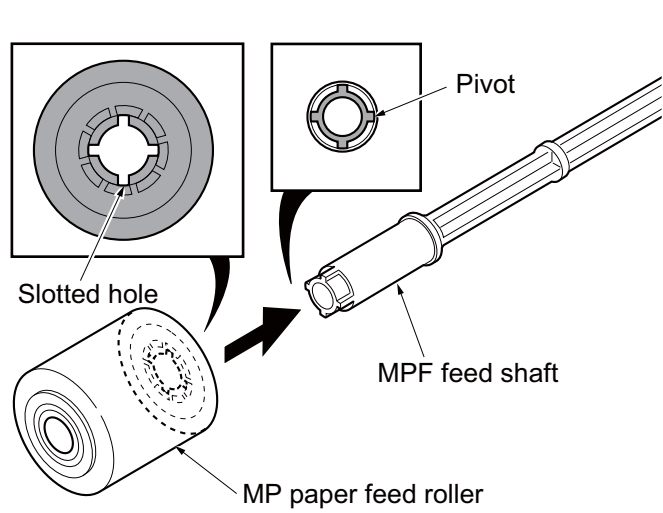

Figure 1-5-14

(4) Note on removing and Installing the upper registration roller and lower registration roller

When reinstalling the upper registration roller or lower registration roller, be sure to use a new registration L spring and registration R spring. Otherwise, paper feeding may be deteriorated due to the spring hooks possibly being distorted during the spring is unhooked.

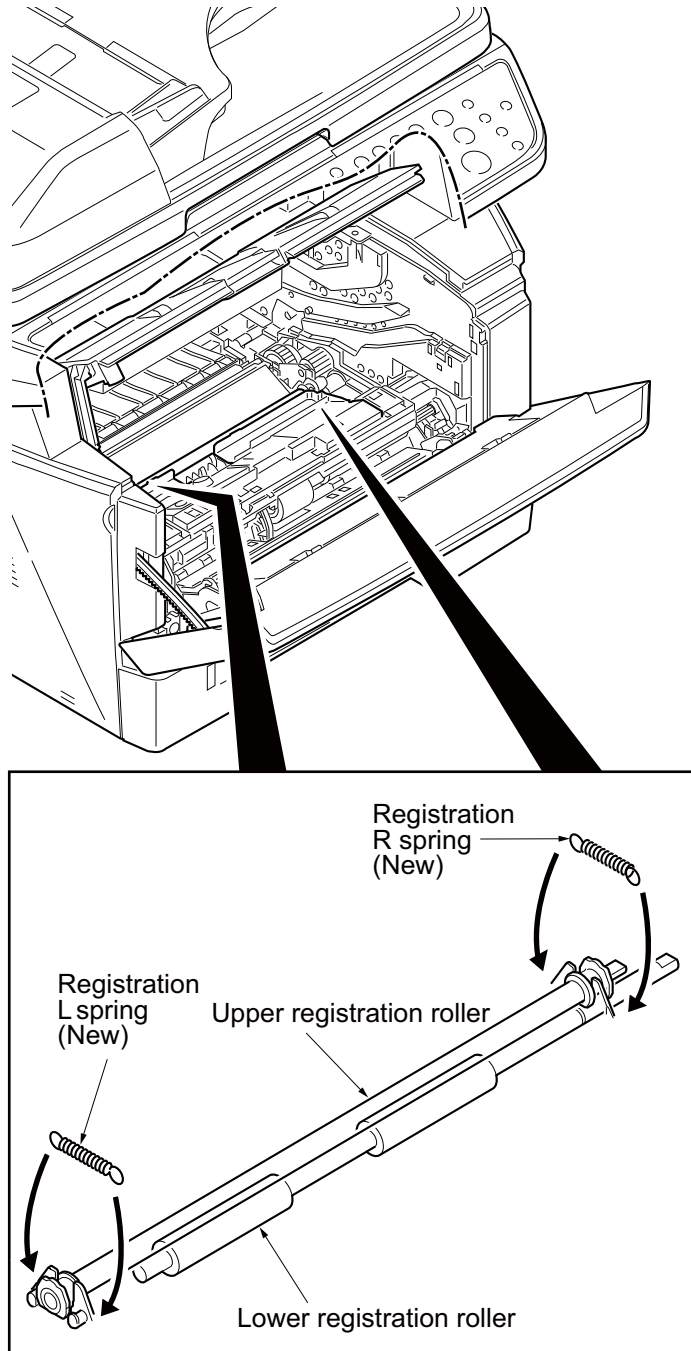

Figure 1-5-15

1-5-4 Optical section

(1) Detaching and refitting the DP

Procedure

1. Pull the DP out.

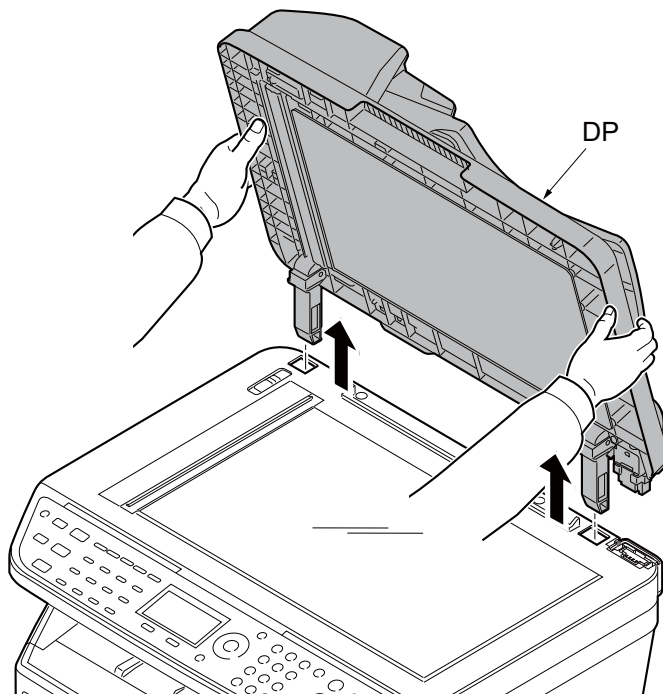

Figure 1-5-16

(2) Detaching and refitting the scanner unit

Procedure

1. Remove the DP (See page 1-5-13).
2. Remove the left cover and right cover (See page 1-5-3).
3. Remove the FFC and connector from the control PWB.
4. Remove three connectors from the scanner PWB.

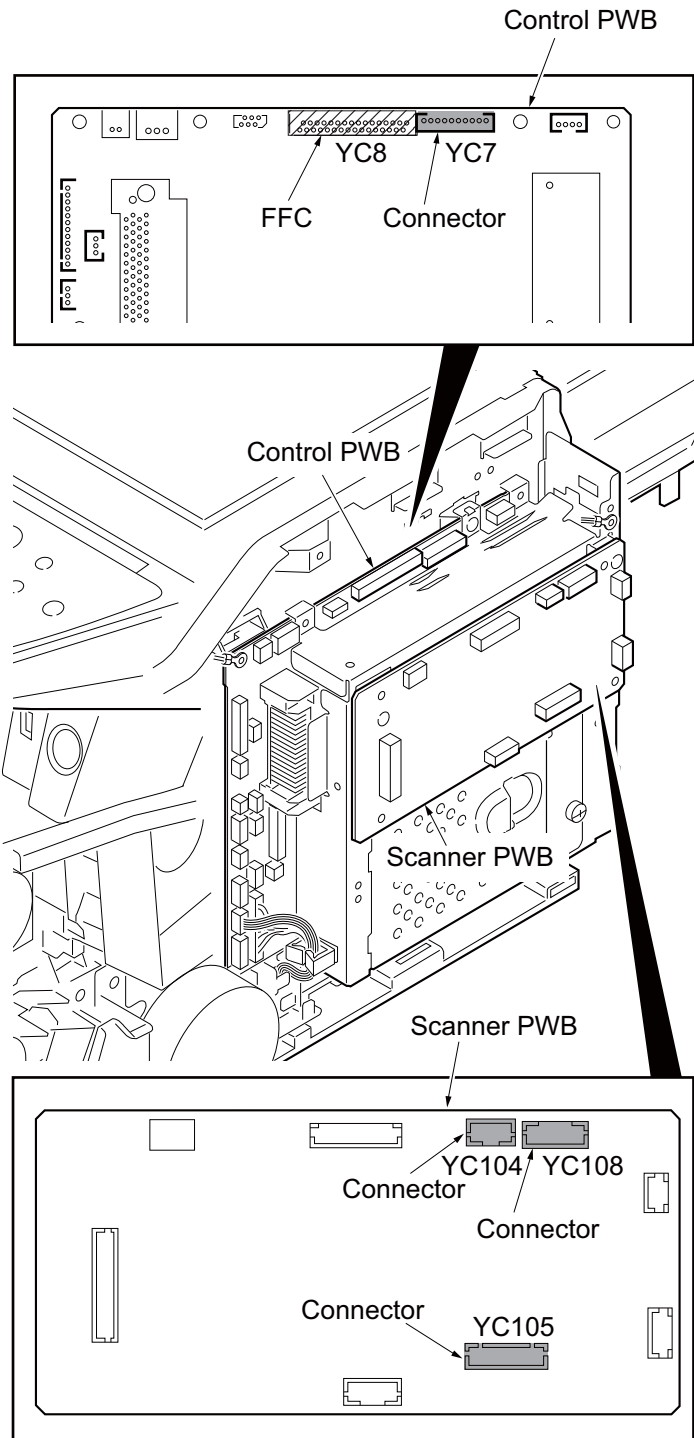

Figure 1-5-17

5. Release three clamps and then remove the wires.

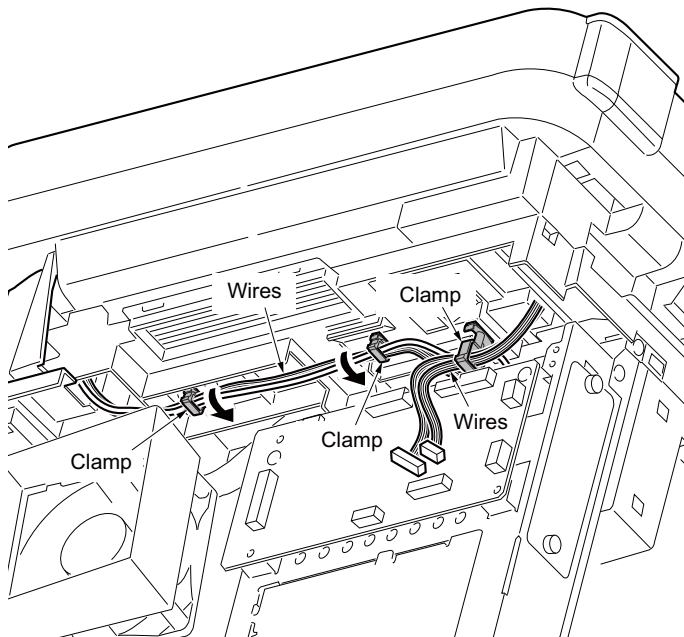

Figure 1-5-18

6. Remove two screws.

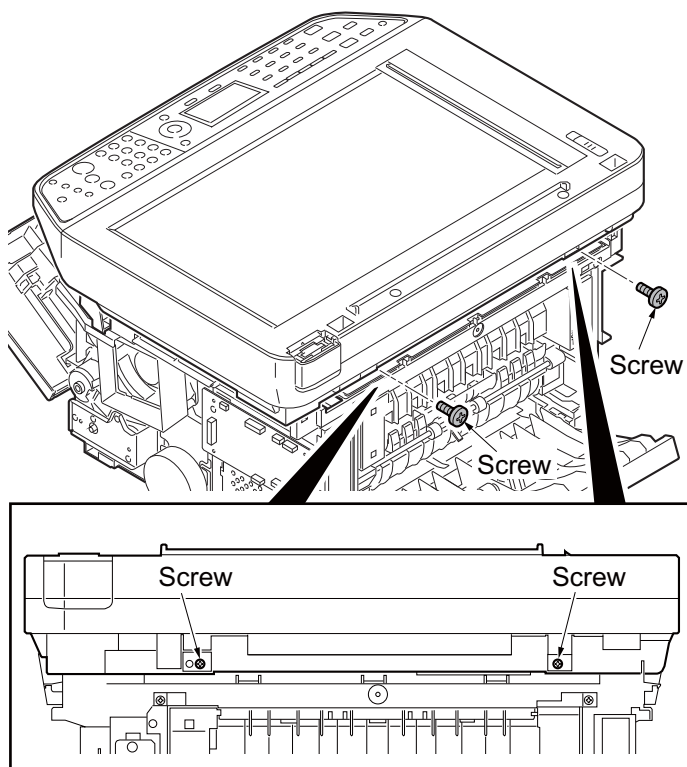

Figure 1-5-19

7. Unhook four hooks and then remove the scanner unit.

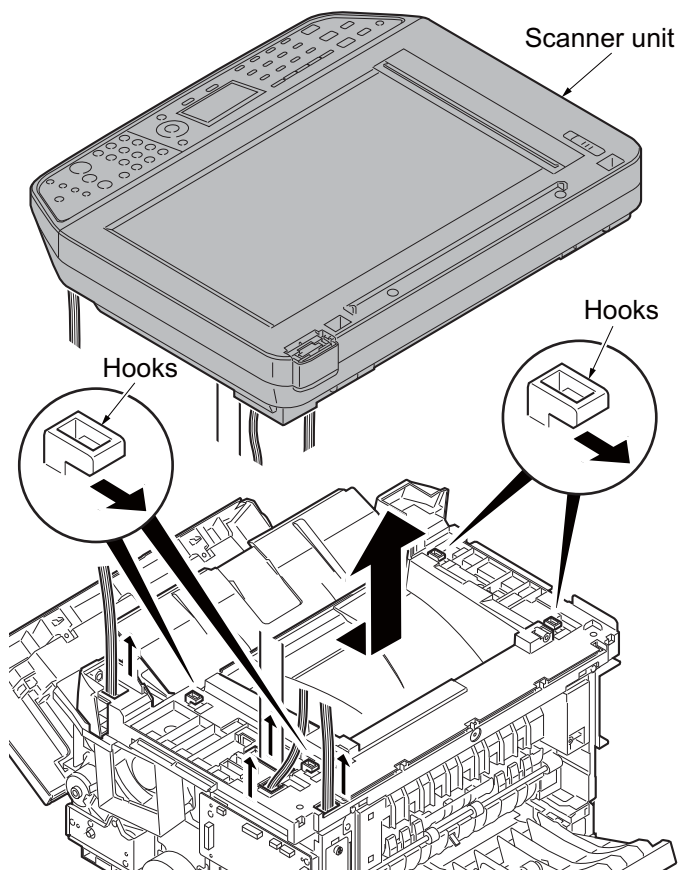

Figure 1-5-20

(3) Detaching and refitting the laser scanner unit (LSU)

Procedure

1. Remove the scanner unit (See page 1-5-14).
2. Remove the screw and then remove the grounding terminal.
3. Remove three connectors from the control PWB.

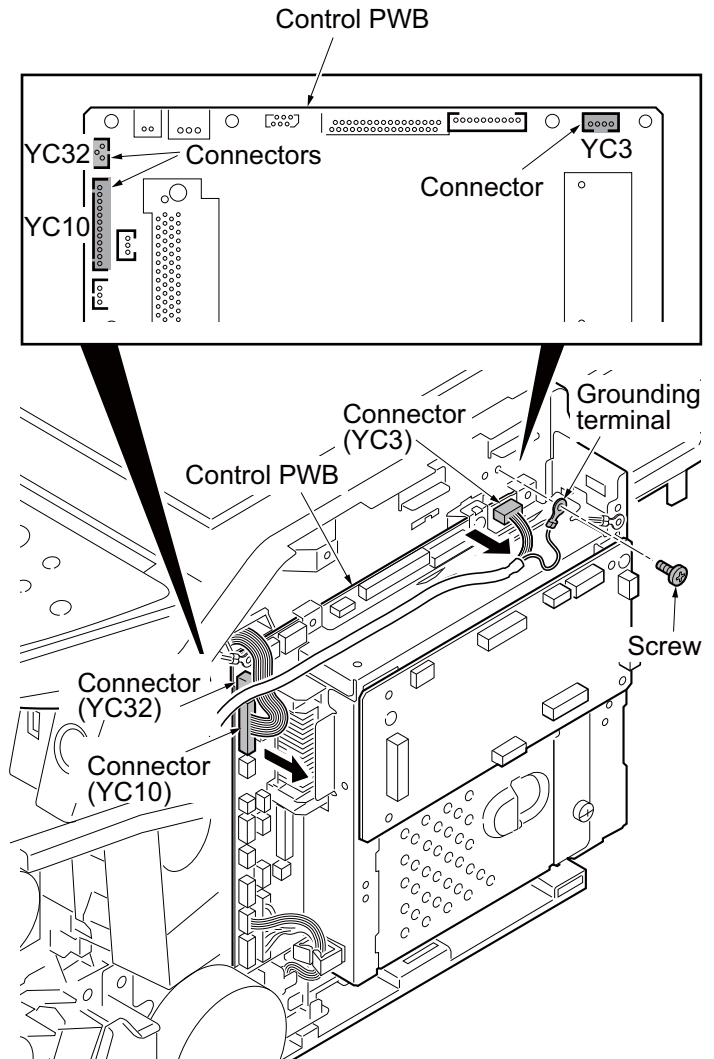

Figure 1-5-21

4. Remove the wires from three clamps.
5. Remove the connector from the power source PWB.

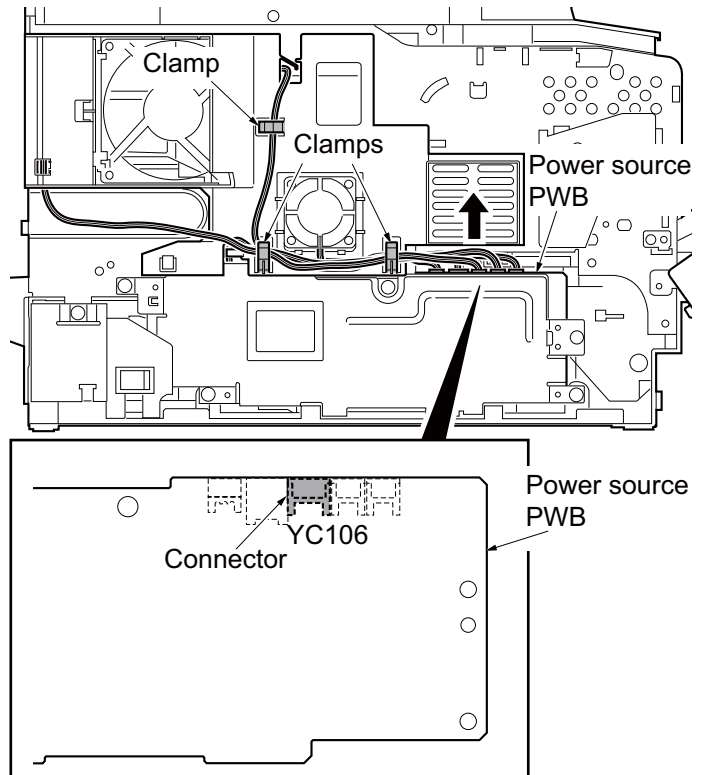

Figure 1-5-22

6. Unhook four hooks and then remove the frame left duct.
7. Remove the wires from the clamp.

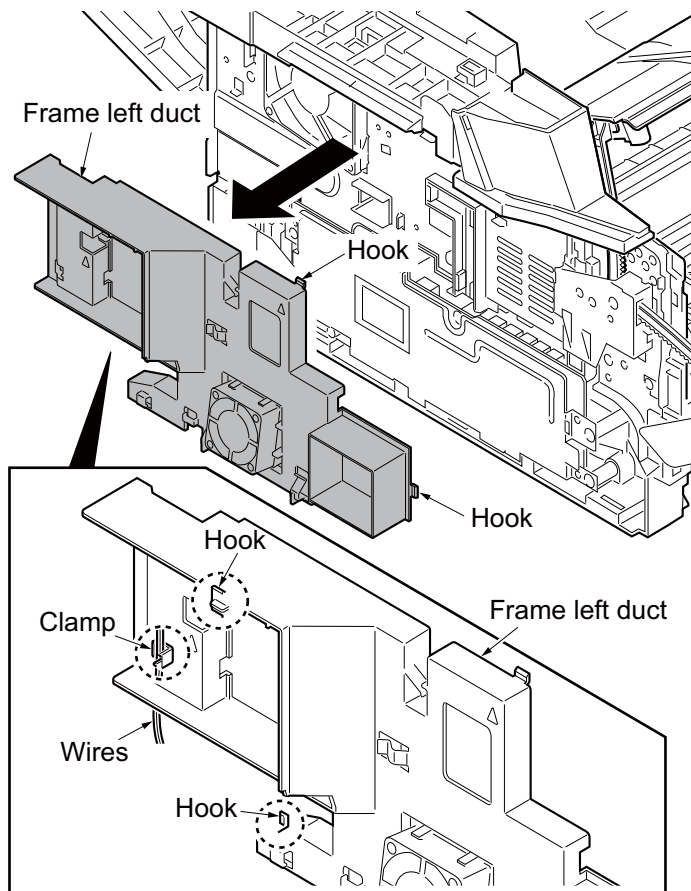

Figure 1-5-23

8. Release the hook and then remove the top cover rack-L from the top cover.

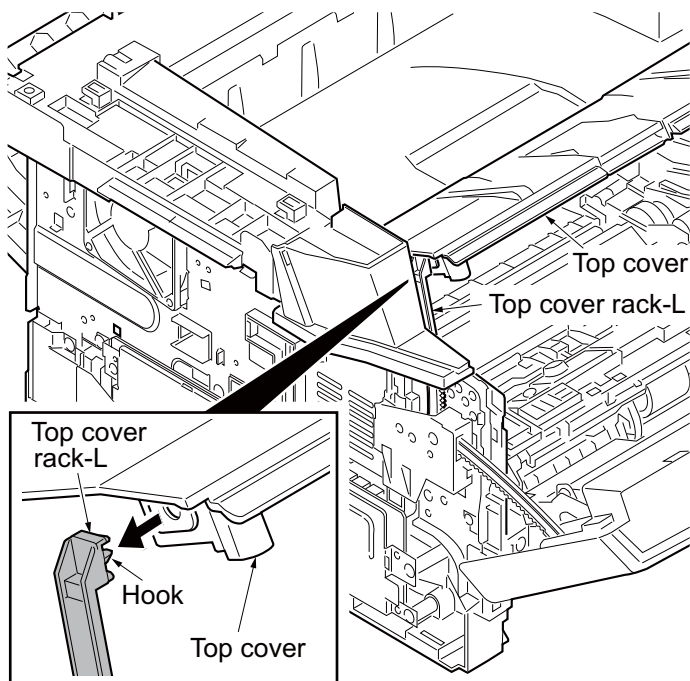

Figure 1-5-24

9. Remove four screws from the top cover.

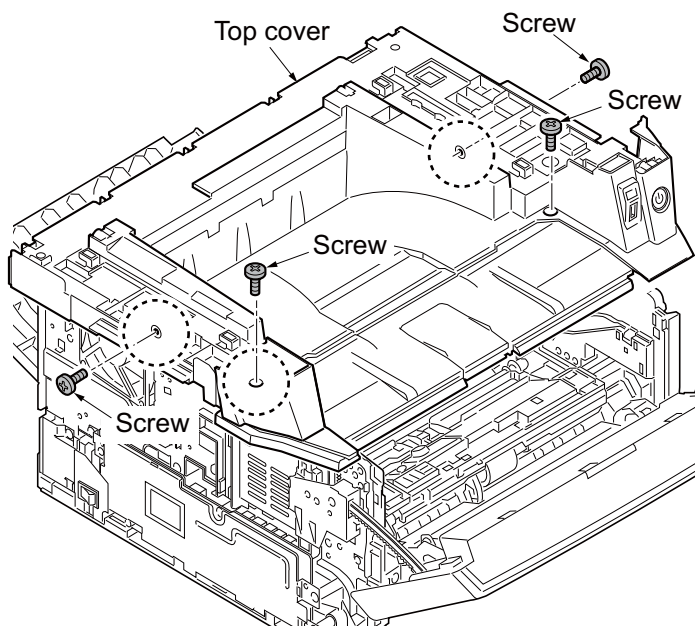

Figure 1-5-25

10. Unhook two hooks and then remove the top cover.

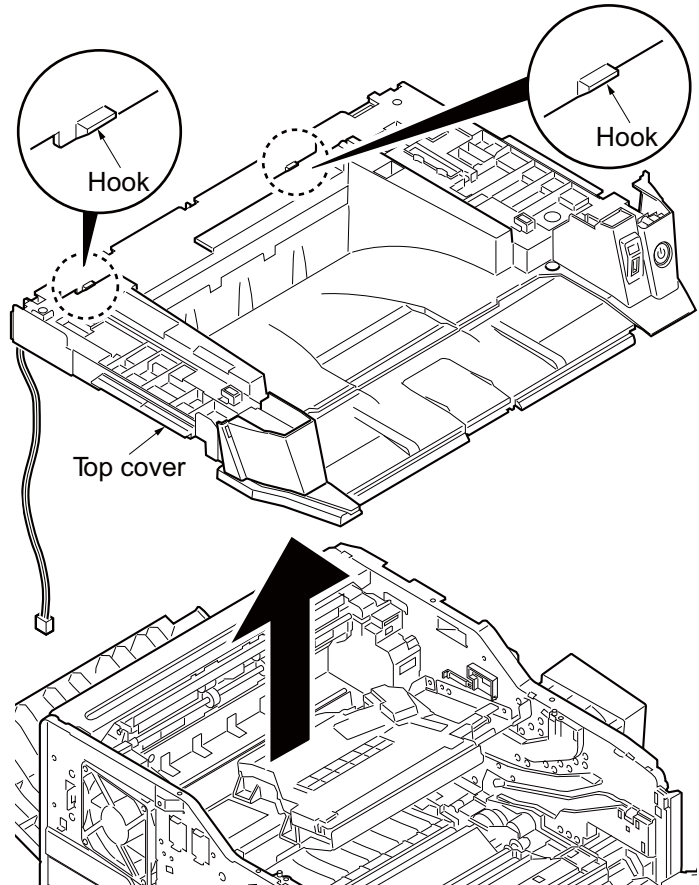

Figure 1-5-26

11. Release the clamp and then pull out the wires.
12. Remove four screws and then remove the laser scanner unit (LSU).
13. Check or replace the laser scanner unit (LSU) and refit all the removed parts.

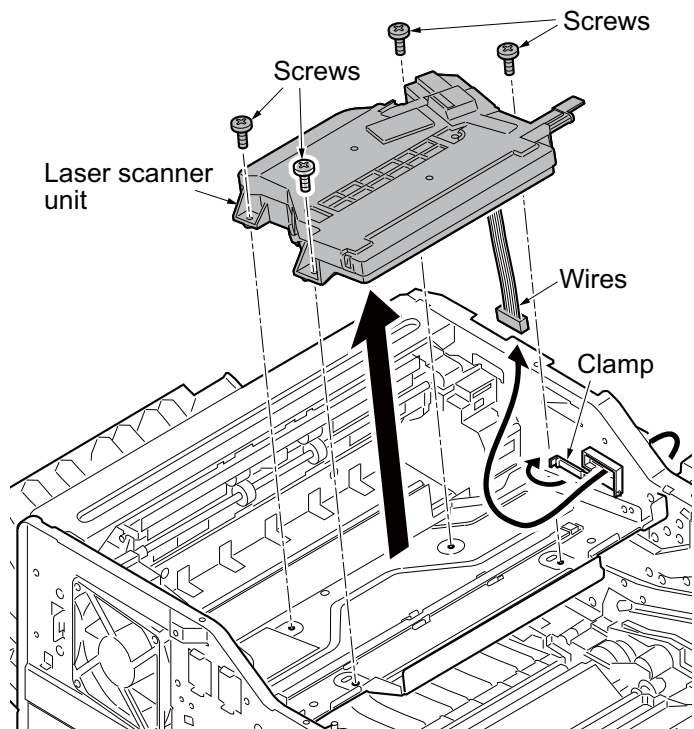

Figure 1-5-27

(4) Replacing the image scanner unit (ISU)

Procedure

Removing the image scanner unit (ISU)

1. Remove the DP (See page 1-5-13).
2. Unhook two hooks by using a flat screwdriver from the pits.
3. Remove the connector and then remove the operation panel.

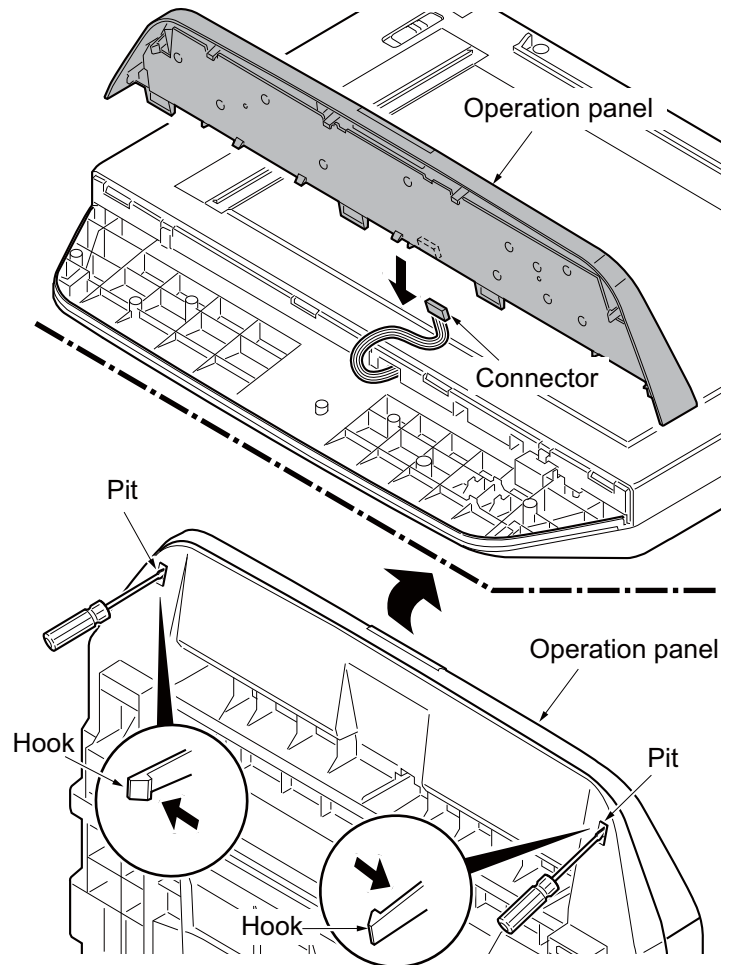

Figure 1-5-28

4. Remove two screws.
5. Unhook three hooks and then remove the ISU upper frame.

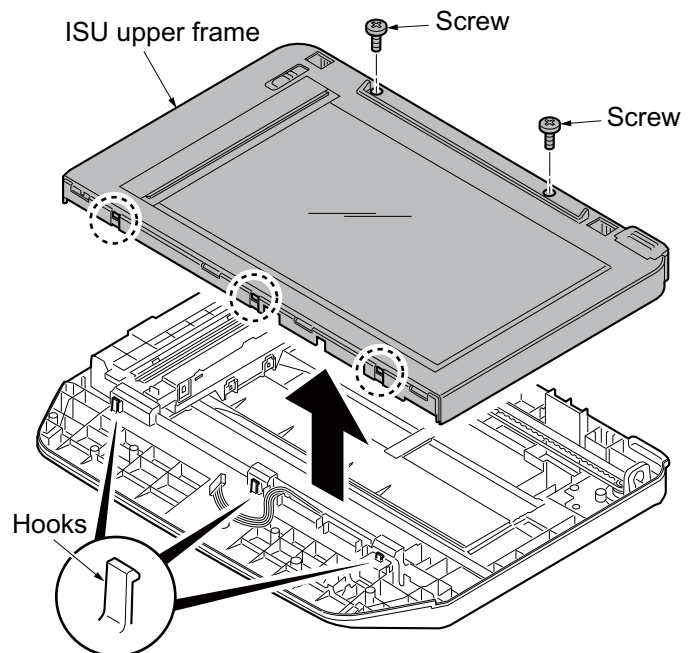

Figure 1-5-29

6. Move the image scanner unit (ISU) in the middle of the ISU shaft.
7. Detach the ISU shaft from the holder by lifting it.
8. Pull the ISU shaft out from the ISU.

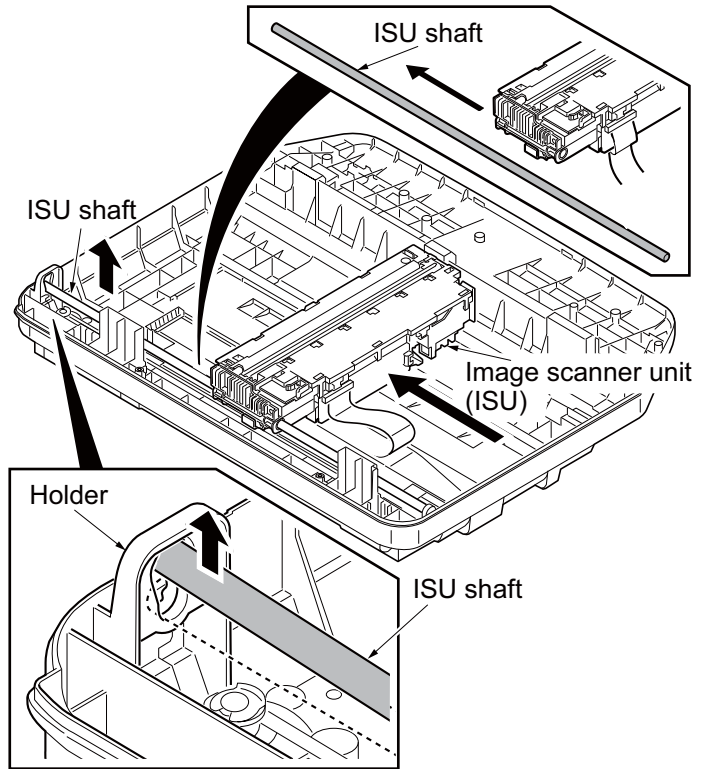

Figure 1-5-30

9. Remove the ISU belt from the tension pulley and ISU gear 63/32.
10. Remove the ISU belt from the hooks of the ISU.

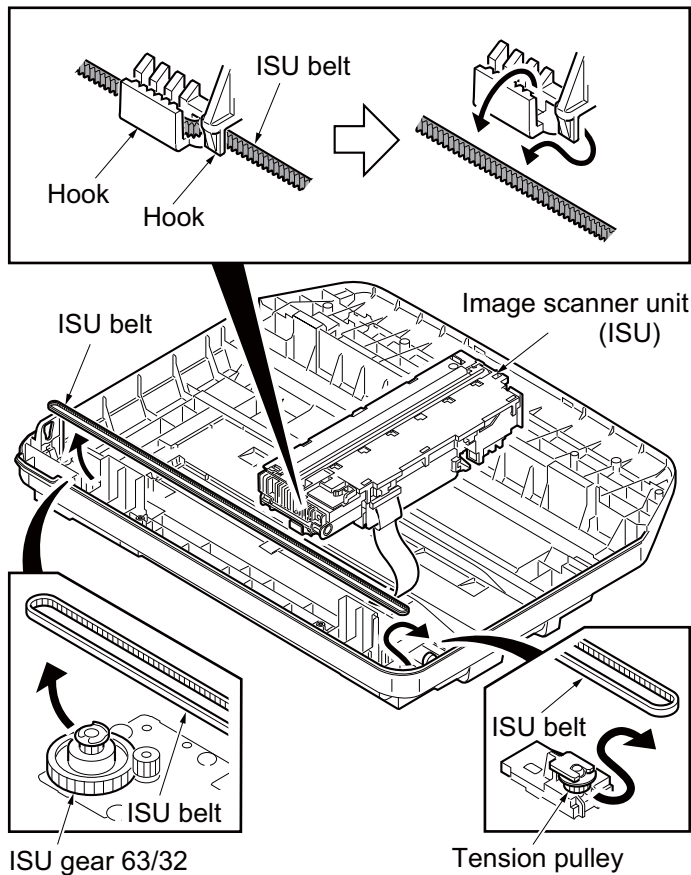

Figure 1-5-31

11. Remove the FFC center stopper.

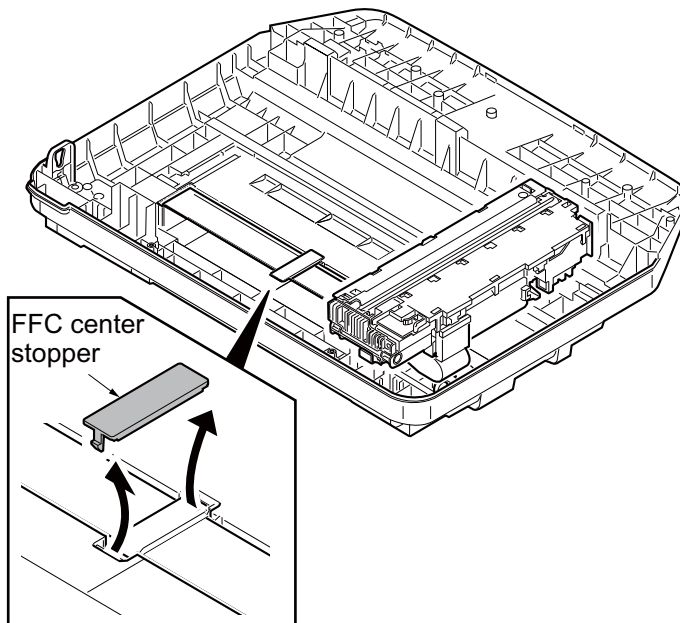

Figure 1-5-32

- 12. Remove the FFC from the FFC tape D.
- 13. Remove the ferrite core from the pit.
- 14. Remove the FFC from the FFC tape A.

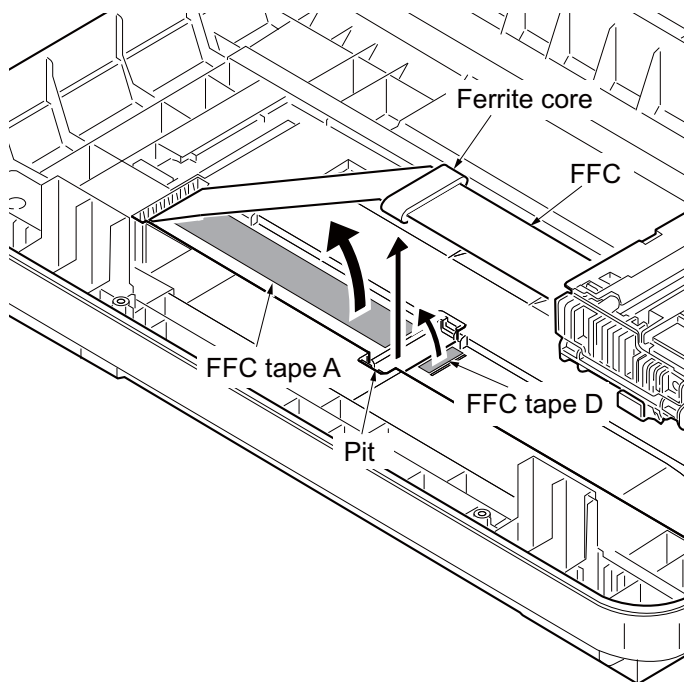

Figure 1-5-33

- 15. Fold the end of the FFC and then pull the FFC out from the ISU lower frame.
- 16. Remove the FFC tape D and A from the ISU lower frame.
- 17. Clean the adhesive residue of the FFC tape D and A.

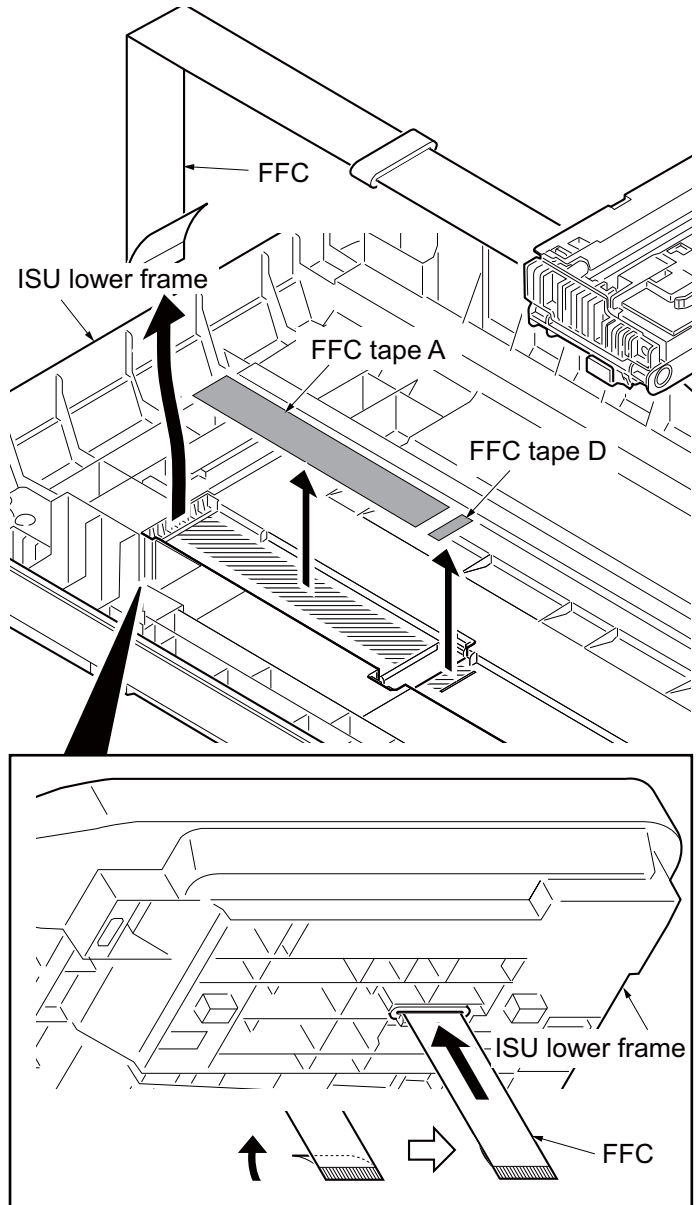

Figure 1-5-34

- 18. Remove the ferrite core from the FFC.

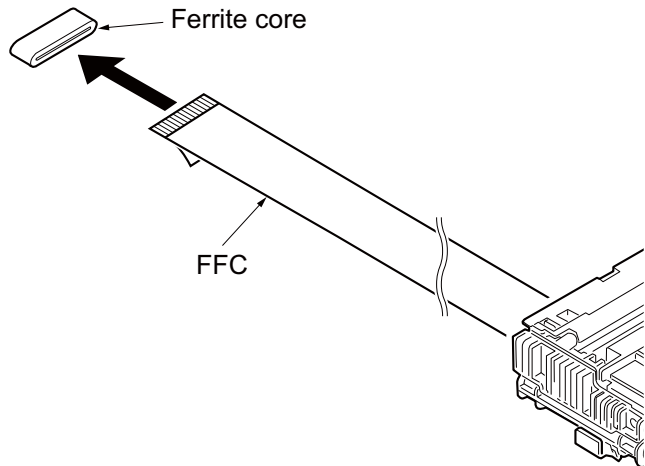

Figure 1-5-35

Installing the image scanner unit (ISU)

1. Peel off the protective seal on one side from the FFC tape D.
2. Stick the FFC tape D on the ISU lower frame, aligned with the marking of the frame.
(Sticking standards: See right figure)
3. Peel off the protective seal on the other side of the FFC tape A.
4. Stick the FFC tape A on the ISU lower frame.
(At the right for how to correctly stick the tape in position, see the figure.)

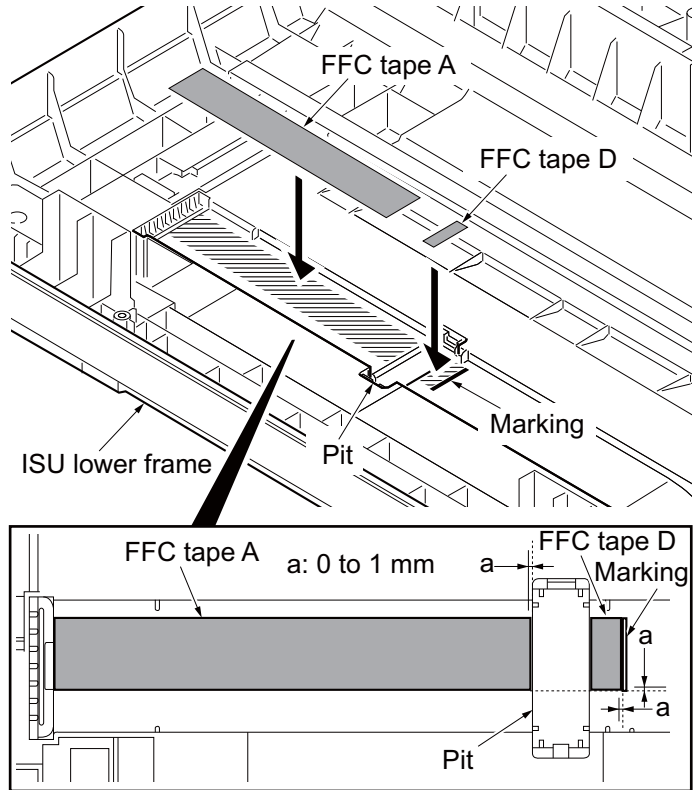

Figure 1-5-36

5. Fix the ferrite core onto the FFC.

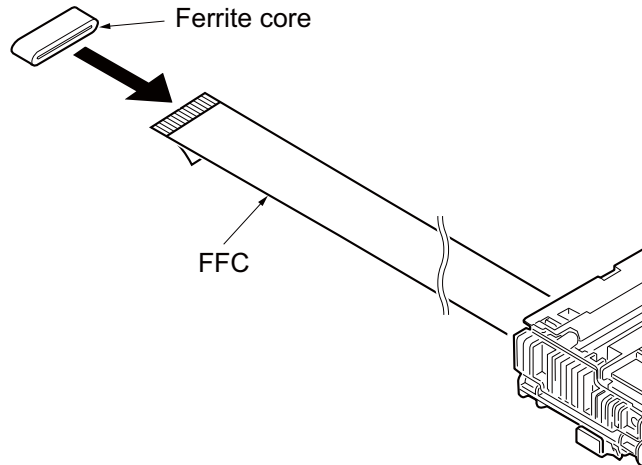

Figure 1-5-37

6. Peel off the protective seal from the FFC tape D.
7. Align the line marking on the FFC with the rib on the ISU lower frame, then fix the FFC to the FFC tape D.
8. Install the ferrite core in the pit.
9. Peel off the released paper from the FFC tape A.
10. Stick the FFC on the FFC tape A.

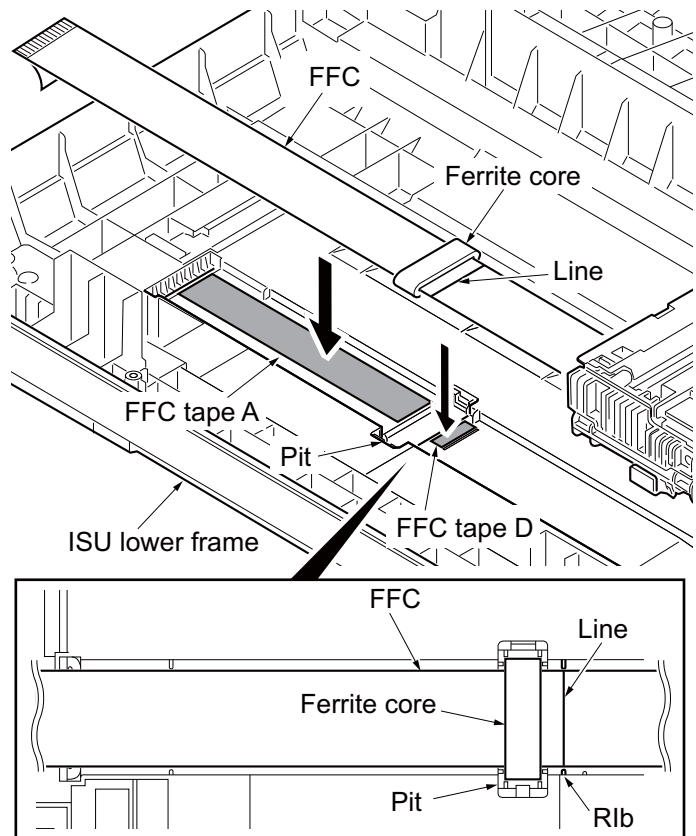

Figure 1-5-38

11. Thread an end of the FFC through the ISU lower frame.
12. Refer to the step 11 to 1 and refit all the removed parts.

NOTE:

When the replacing the image scanner unit (ISU), perform following maintenance modes.

1. U425 Setting the target (see page 1-3-20)
2. U411 Adjusting the scanner automatically (see page 1-3-18)

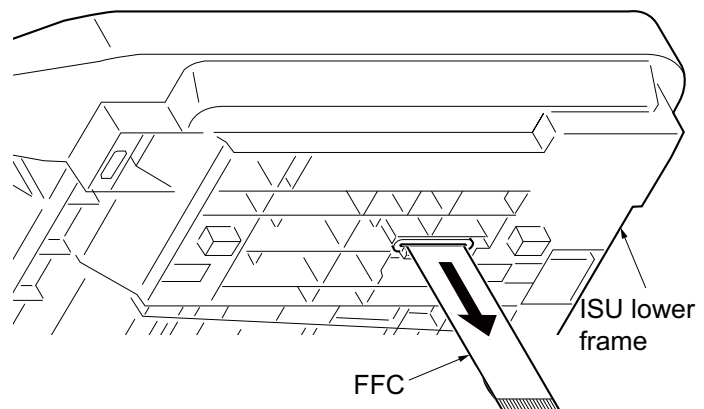

Figure 1-5-39

1-5-5 Developer section

(1) Detaching and refitting the developer unit

Procedure

1. Open the front cover.
2. Remove the developer unit.
3. Check or replace the developer unit and refit all the removed parts.

NOTE:

When the periodic maintenance (replacing the maintenance kit, see page 2-4-4), perform following maintenance modes.

1. U251 Clearing the maintenance count (see page 1-3-14)

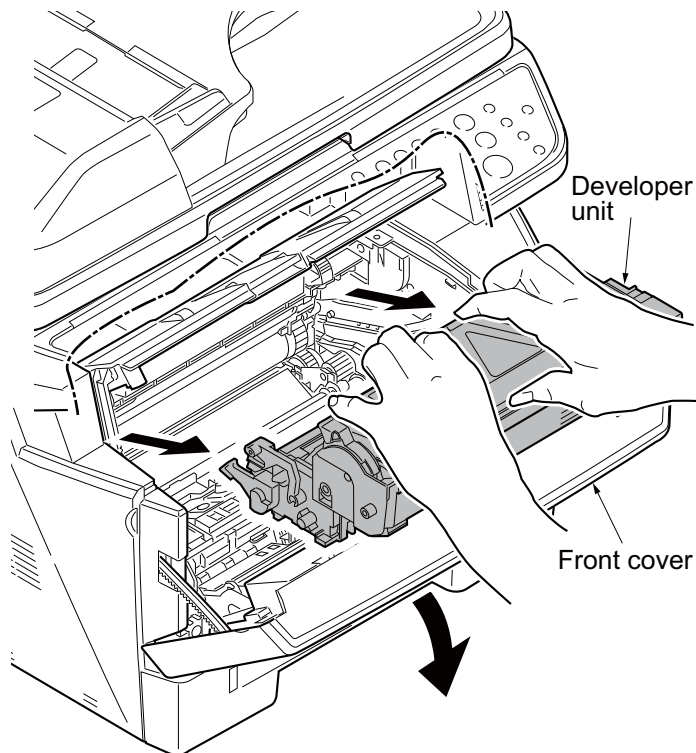

Figure 1-5-40

1-5-6 Drum section

(1) Detaching and refitting the drum unit

Procedure

1. Remove the developer unit (See page 1-5-27).
2. Remove the drum unit.
3. Check or replace the drum unit and refit all the removed parts.

NOTE:

When the periodic maintenance (replacing the maintenance kit, see page 2-4-4), perform following maintenance modes.

1. U251 Clearing the maintenance count (see page 1-3-14)

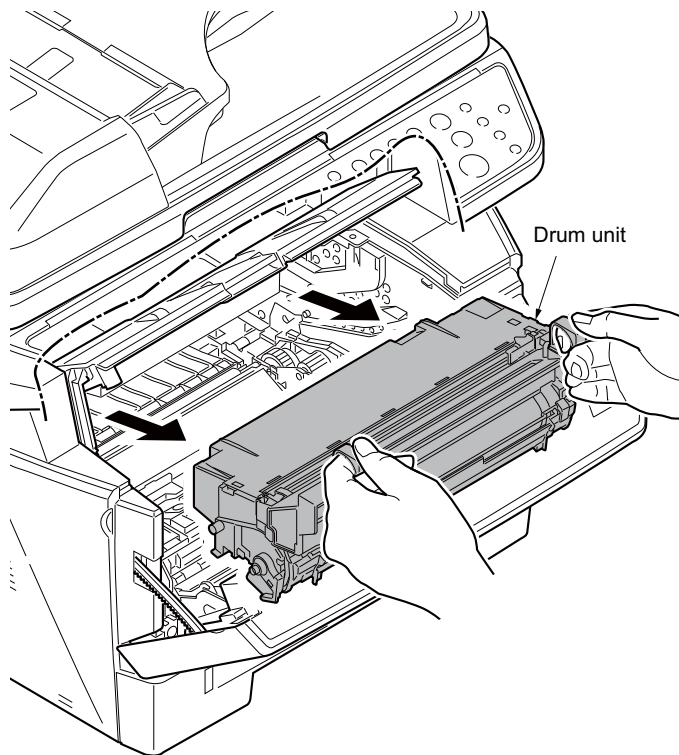

Figure 1-5-41

(2) Detaching and refitting the main charger unit

Procedure

1. Remove the developer unit (See page 1-5-27).
2. Remove the drum unit (See page 1-5-28).
3. Remove the tape.
4. While pushing on the main plate 1, slide the main charger unit 2.

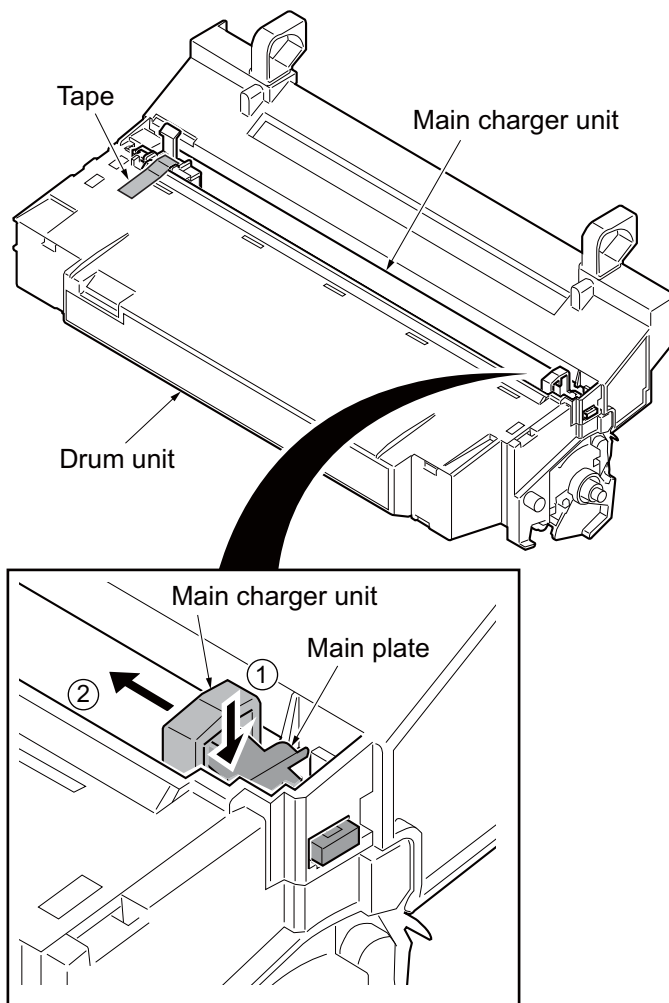

Figure 1-5-42

5. Remove the main charger unit by lifting it.
6. Check or replace the main charger unit and refit all the removed parts.

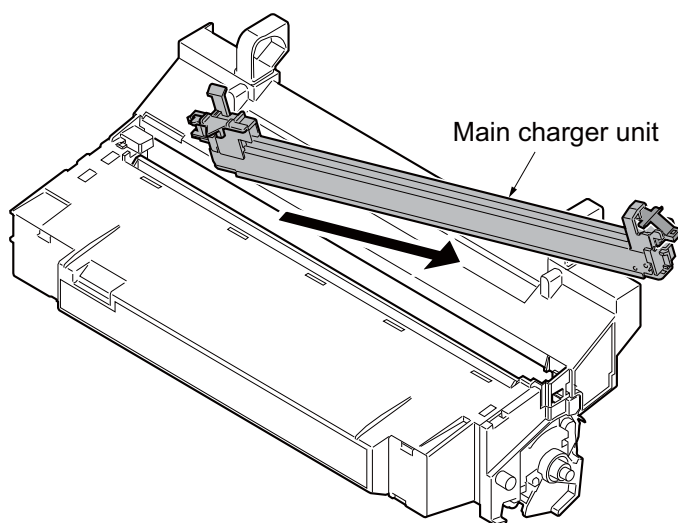

Figure 1-5-43

1-5-7 Transfer/separation section

(1) Detaching and refitting the transfer roller

Procedure

1. Remove the developer unit (See page 1-5-27).
2. Remove the drum unit (See page 1-5-28).
3. Slide the paper chute guide and unhook the hooks.
4. Remove the paper chute guide.

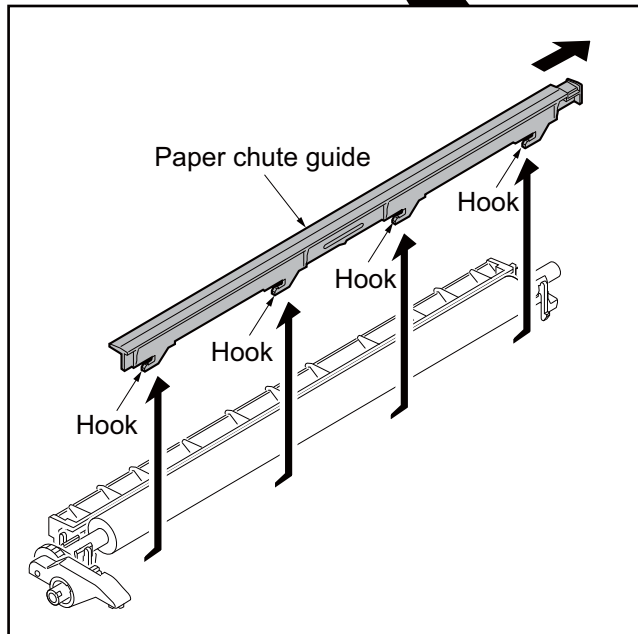
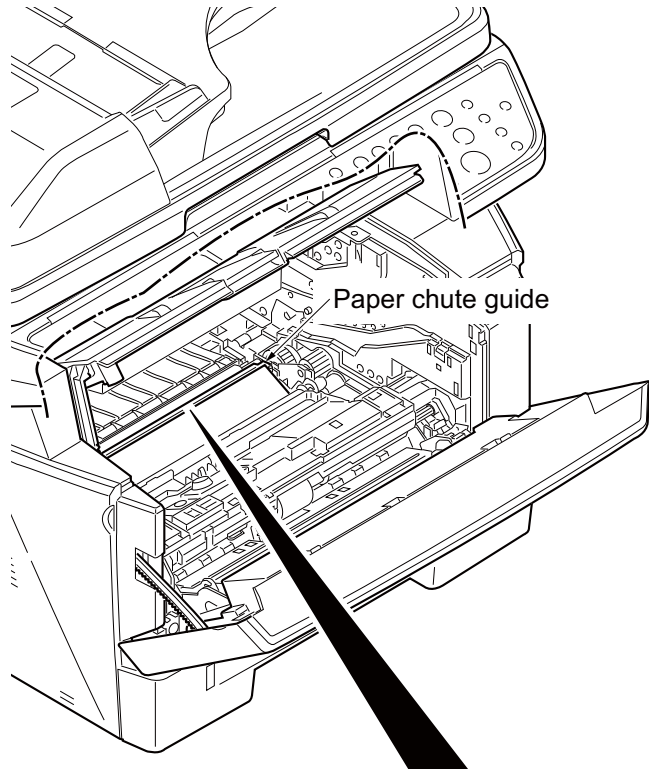

Figure 1-5-44

5. Remove the transfer roller's shaft from the both transfer bushes.
6. Remove the gear Z16 from the transfer roller.

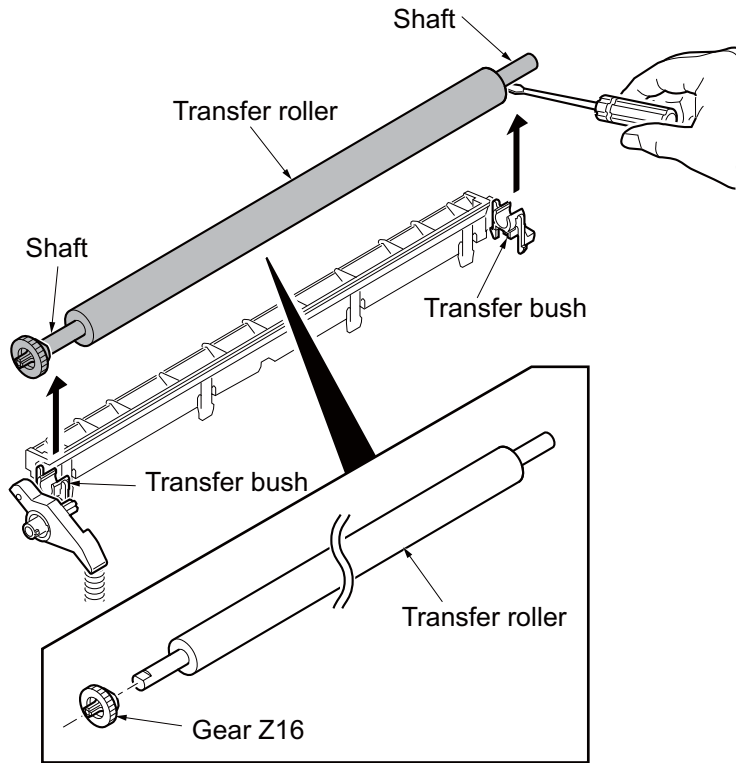

Figure 1-5-45

7. Check or replace the transfer roller and refit all the removed parts.

Caution: When refitting the transfer roller, be careful about following point. Push the release lever to raise the lever end, then insert the front of gear Z16 under the release lever end.

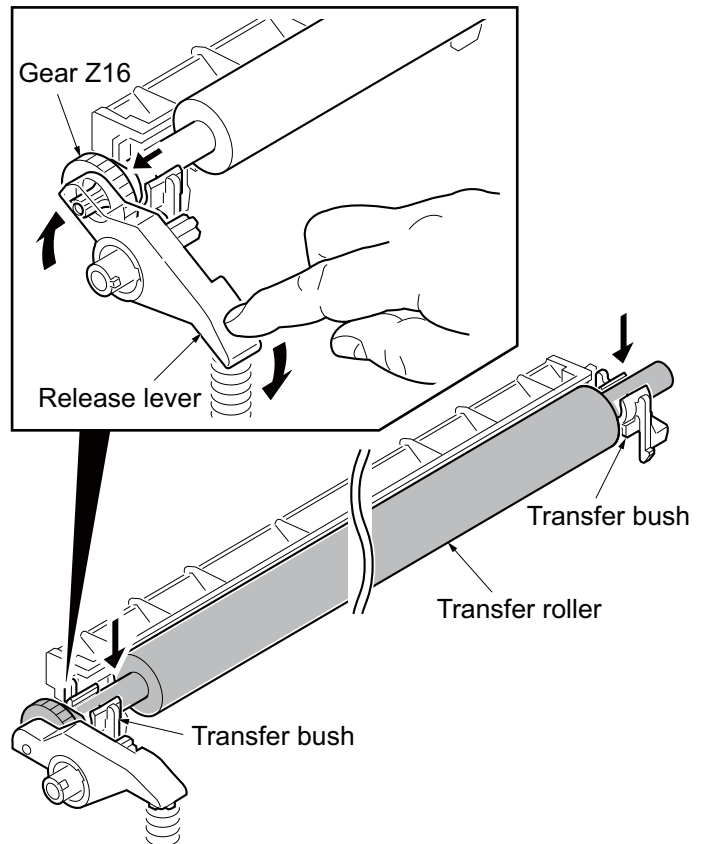

Figure 1-5-46

1-5-8 Fuser section

(1) Detaching and refitting the fuser unit

Procedure

1. Remove the left cover and right cover
(See page 1-5-3).
2. Remove the wires from three clamps.
3. Remove the connector from the power source PWB.

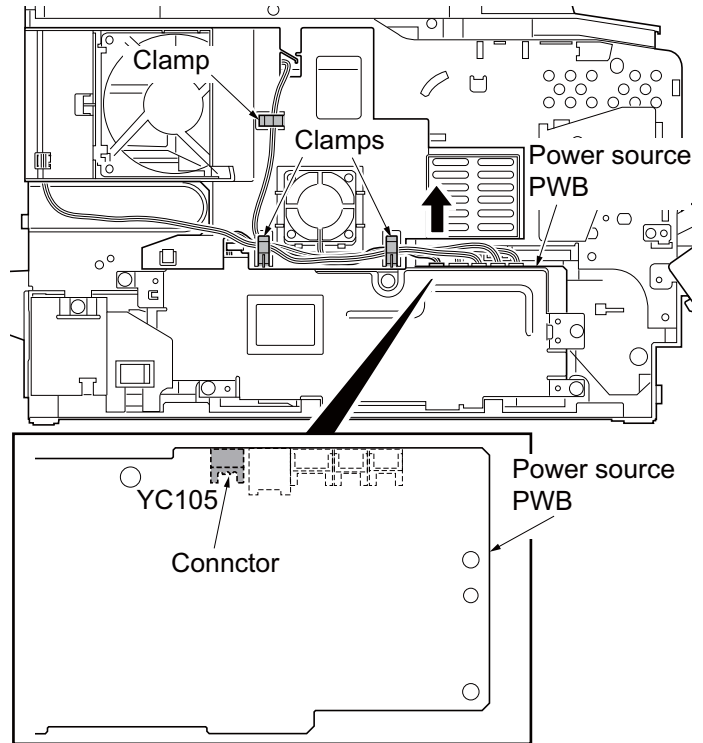

Figure 1-5-47

4. Unhook four hooks and then remove the frame left duct.
5. Remove the wires from the clamp.

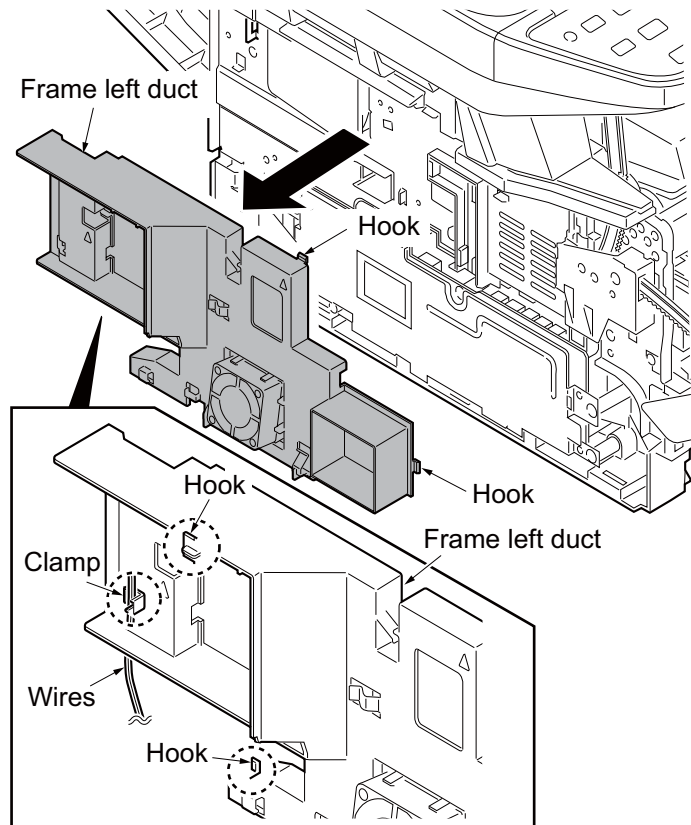

Figure 1-5-48

- 6. Remove the connector from the power source PWB.

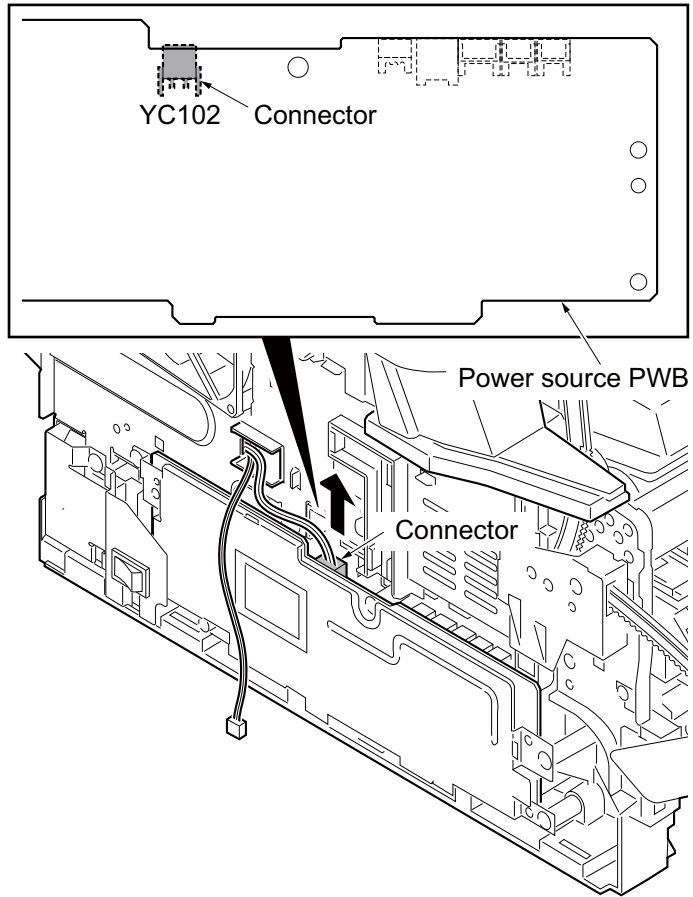

Figure 1-5-49

- 7. Remove the connector from the control PWB.

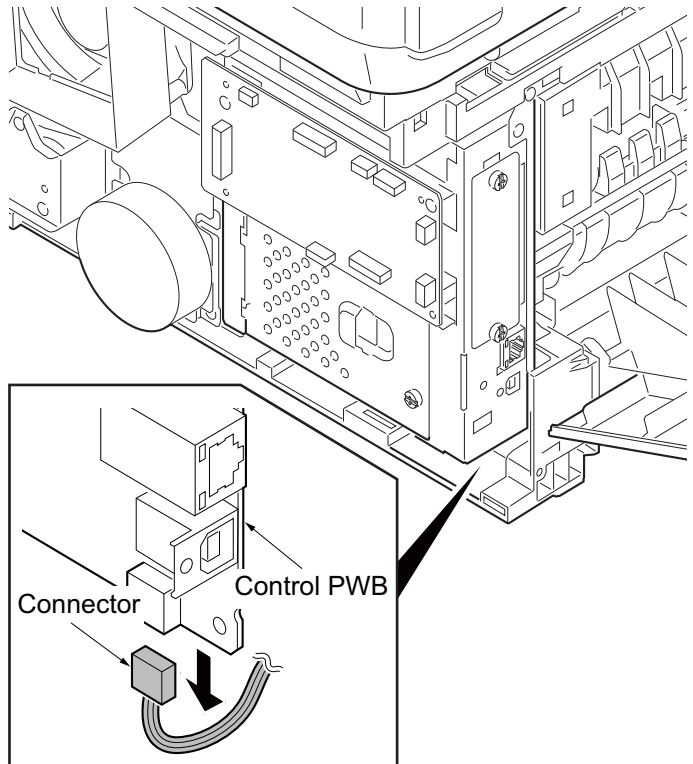

Figure 1-5-50

8. Remove the rear cover.

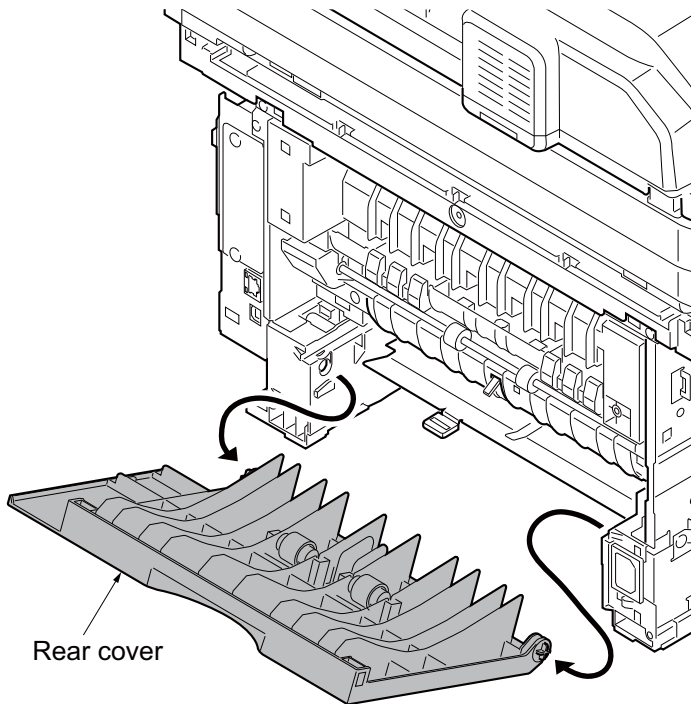

Figure 1-5-51

9. Remove two screws and then remove the fuser unit.

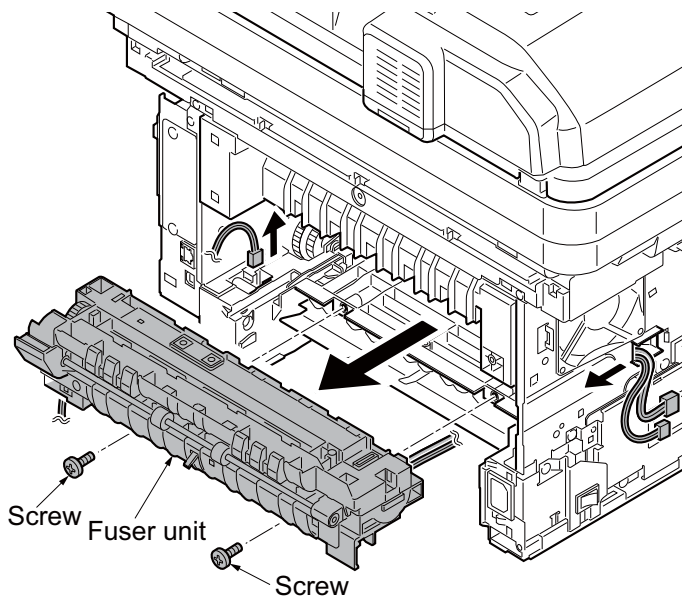

Figure 1-5-52

10. Check or replace the fuser unit and refit all the removed parts.

Caution: When reinstalling the fuser unit, tighten up a screw while pressing the fuser unit in order of 1 to 2.

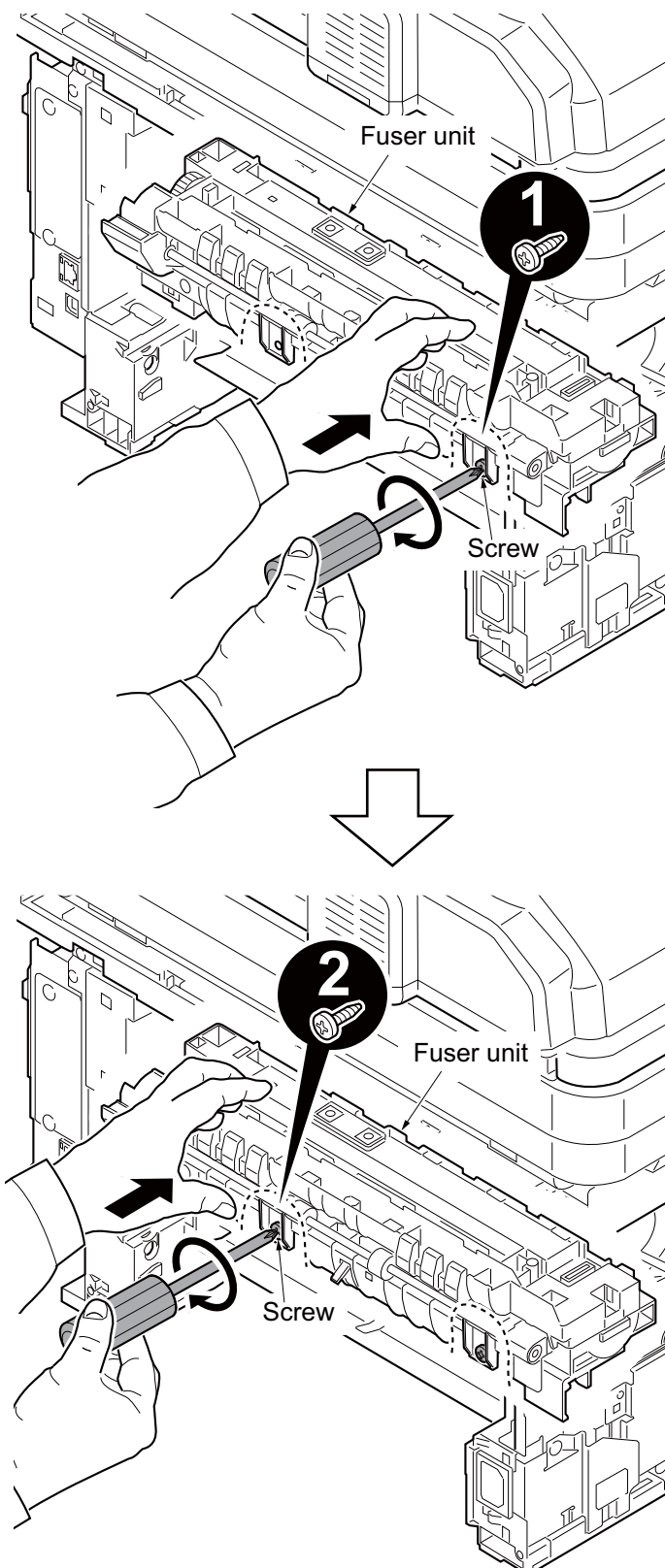

Figure 1-5-53

(2) Switching the fuser pressure

The fuser pressure may be decreased to suppress the print quality problems such as paper creases and curls.

It must be cautioned that decreasing the fuser pressure could cause loose toner fusing.

Procedure

1. Remove the cassette (See page 1-5-6).
2. Open the duplex cover.
3. Slide the fuser lever R and L.
 Normal: Flush with the front of the machine.
 Fuser pressure decreased: Flush with the rear of the machine.

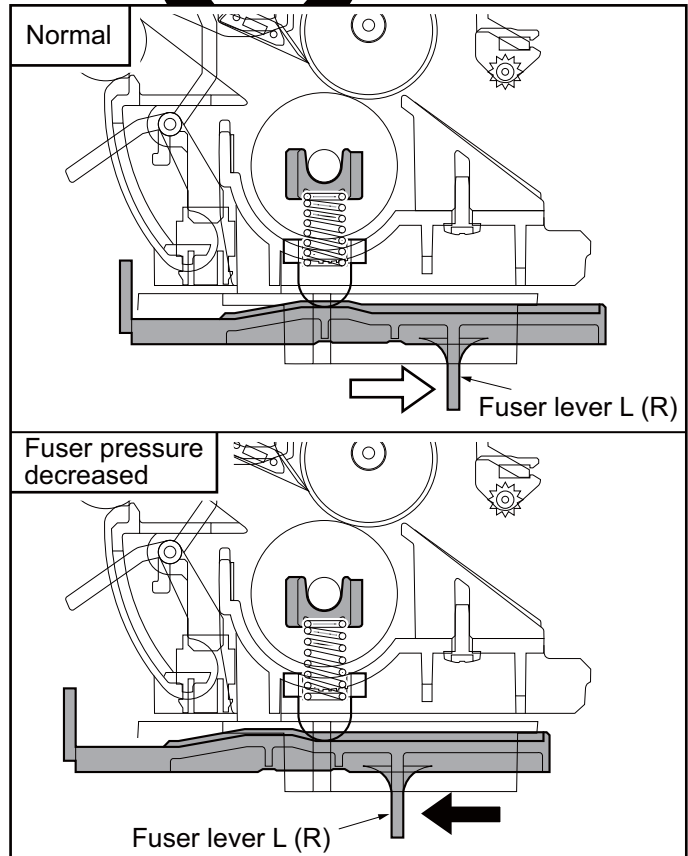
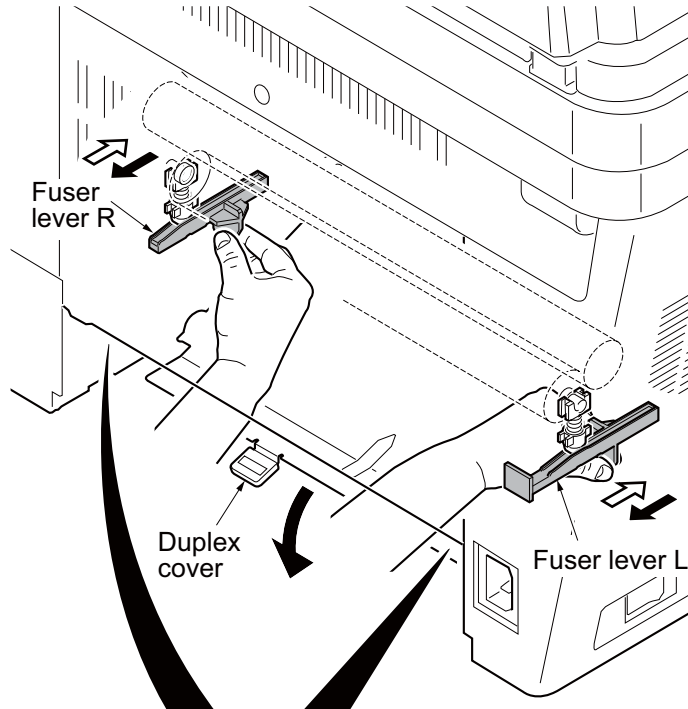

Figure 1-5-37

1-5-9 PWBs

(1) Detaching and refitting the control PWB

Procedure

1. Remove the FAX control PWB.
(See page 1-5-48)
2. Remove the right cover.
(See page 1-5-3)
3. Remove the five connectors from the scanner PWB.
4. Remove twenty connectors and two FFCs from the control PWB.
5. Remove the wires from the clamp.

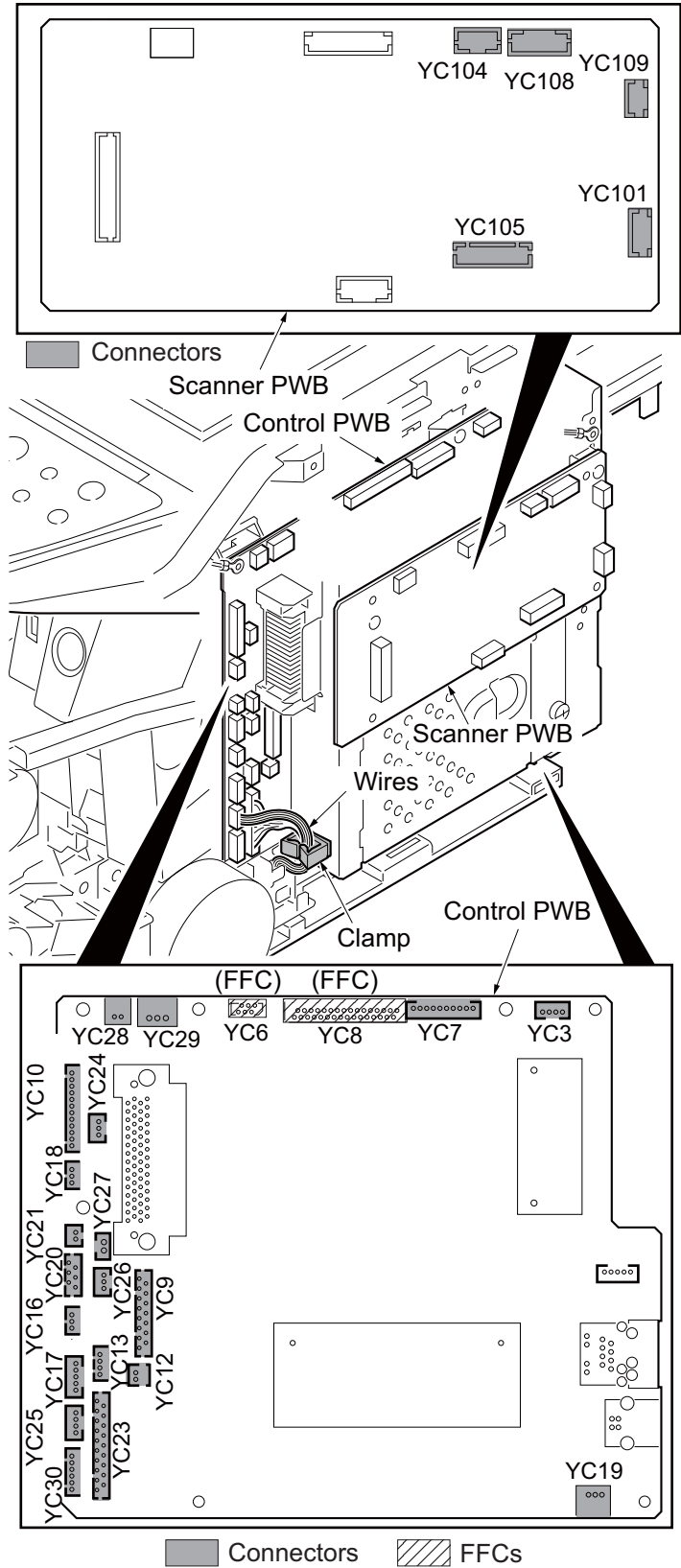

Figure 1-5-55

- Remove five screws and then remove the control box.

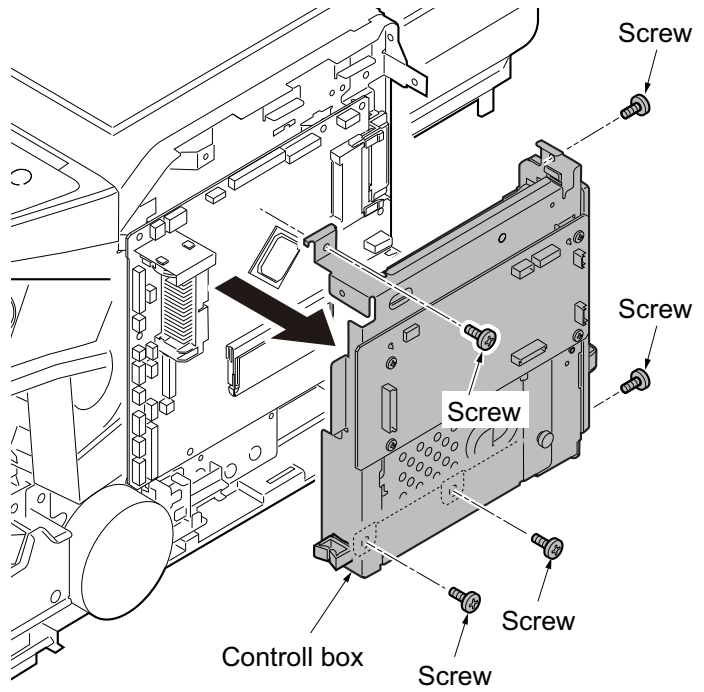

Figure 1-5-56

- Remove seven screws and two grounding terminals and then remove the control PWB.

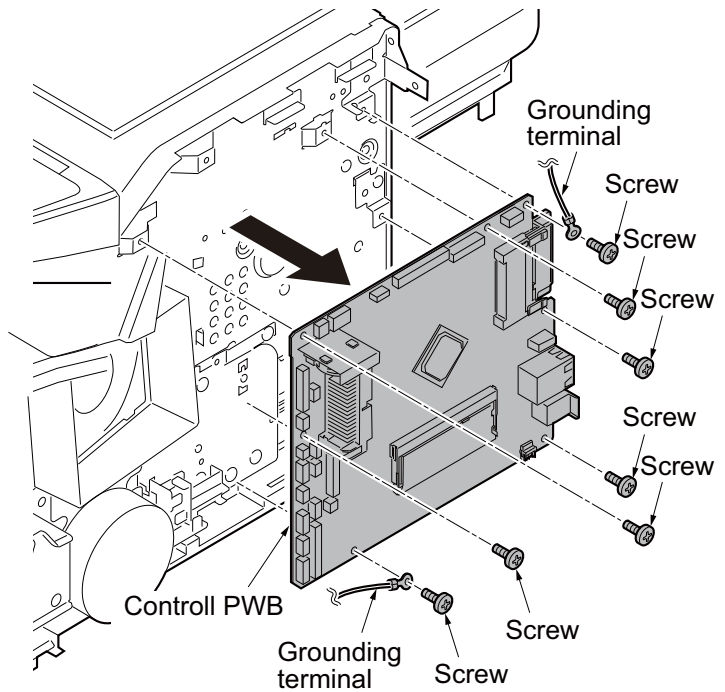

Figure 1-5-57

8. Remove five screws and then remove the control PWB.
9. Check or replace the control PWB and refit all the removed parts.

To replace the control PWB, remove the EEPROM (U17) from the old control PWB and mount it to the new control PWB.

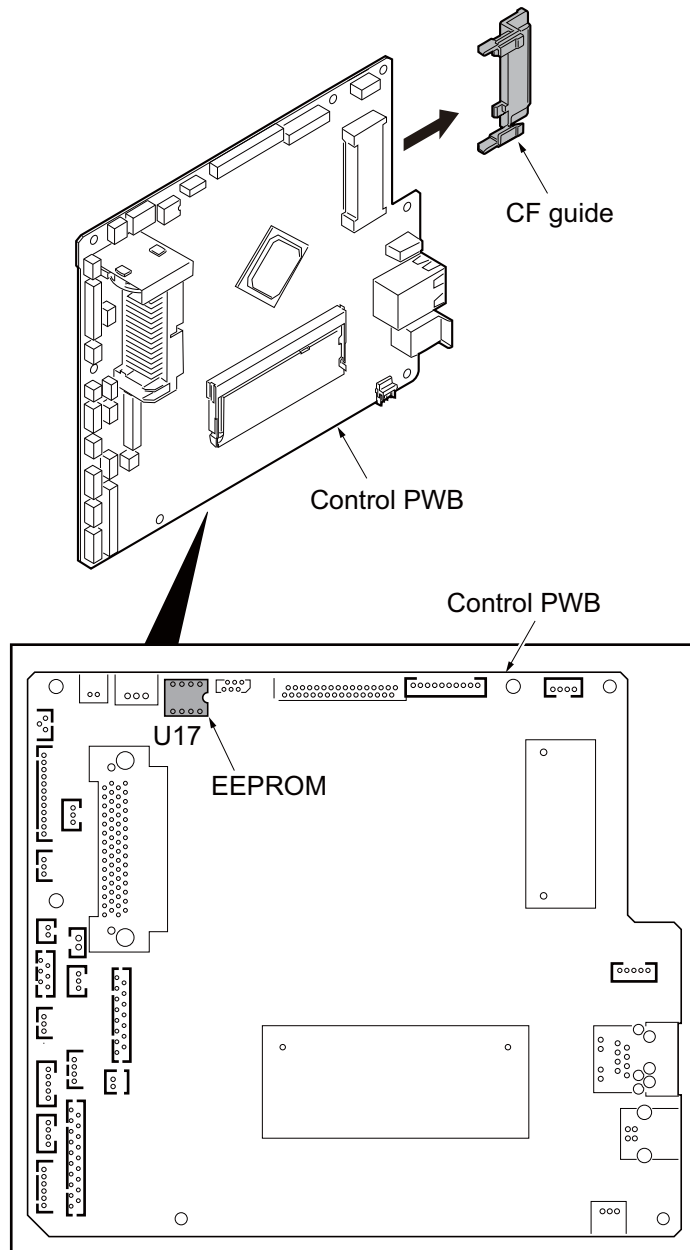

Figure 1-5-58

(2) Detaching and refitting the power source PWB

Procedure

1. Remove the left cover (See page 1-5-3).
2. Remove the wires from three clamps.
3. Remove five connectors from the power source PWB.

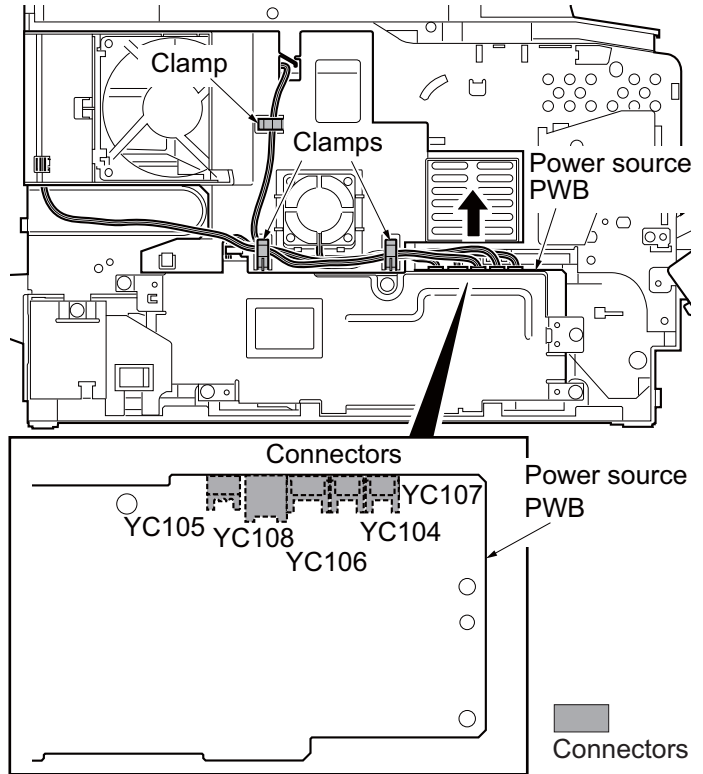

Figure 1-5-59

4. Unhook four hooks and then remove the frame left duct.
5. Remove the wire from the clamp.

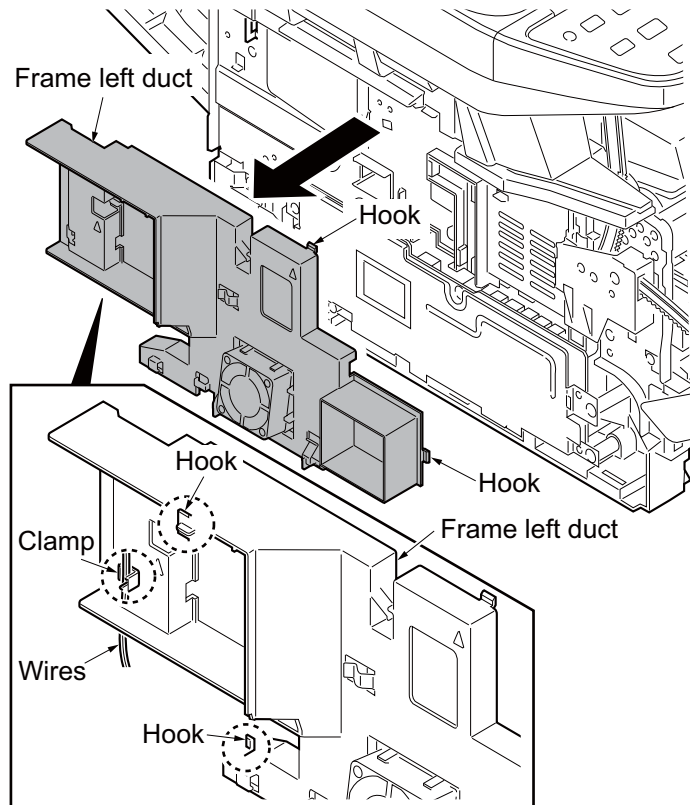

Figure 1-5-60

6. Remove the screw and then detach the inlet mount.

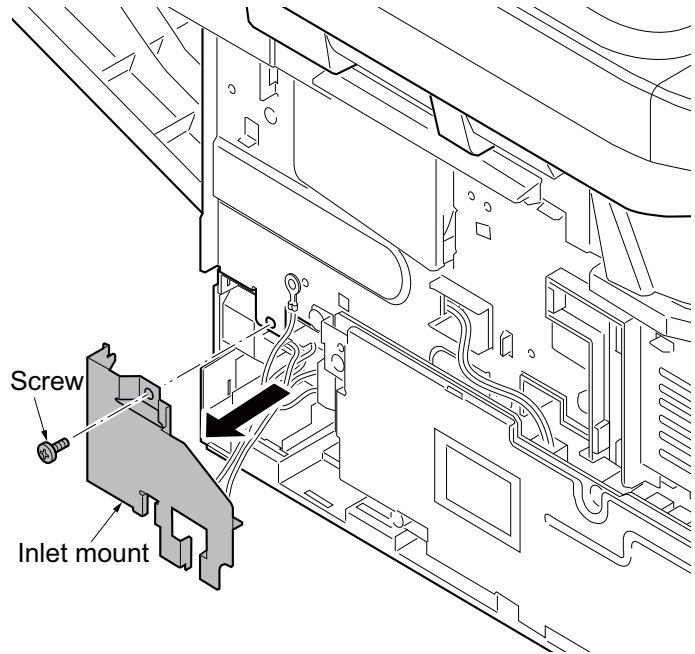

Figure 1-5-61

7. Remove five screws.
8. Remove two connectors and then remove the power source PWB assembly.

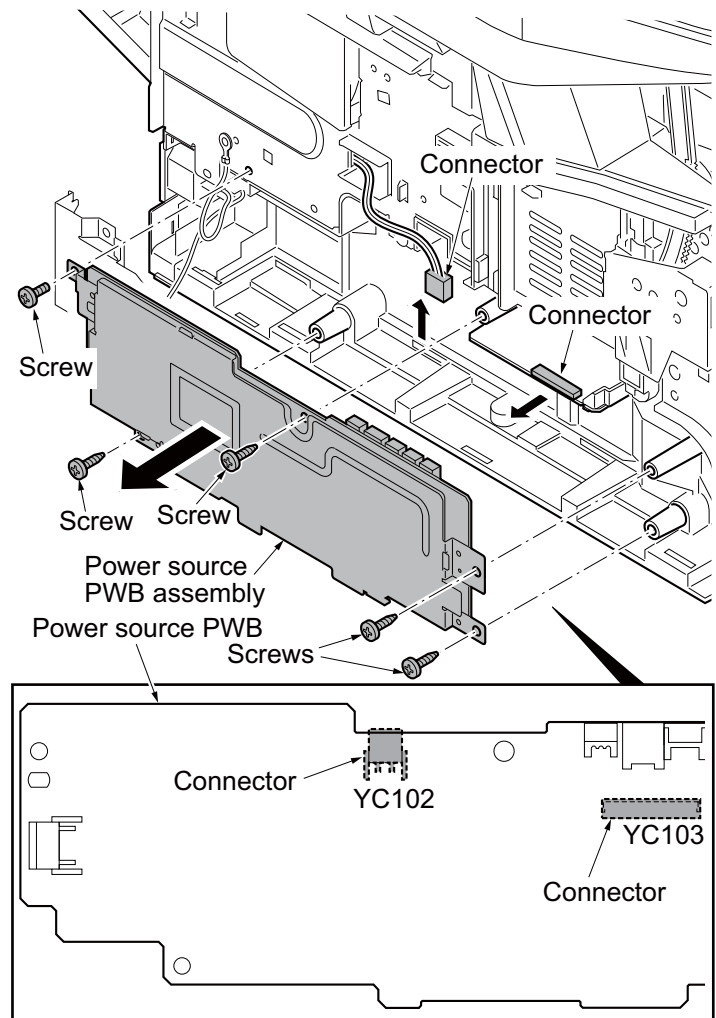

Figure 1-5-62

9. Remove four screws and then remove the power source PWB from the power source PWB plate.
10. Check or replace the power source PWB and refit all the removed parts.

Caution: The power source PWB sheet must be installed in the specified position.

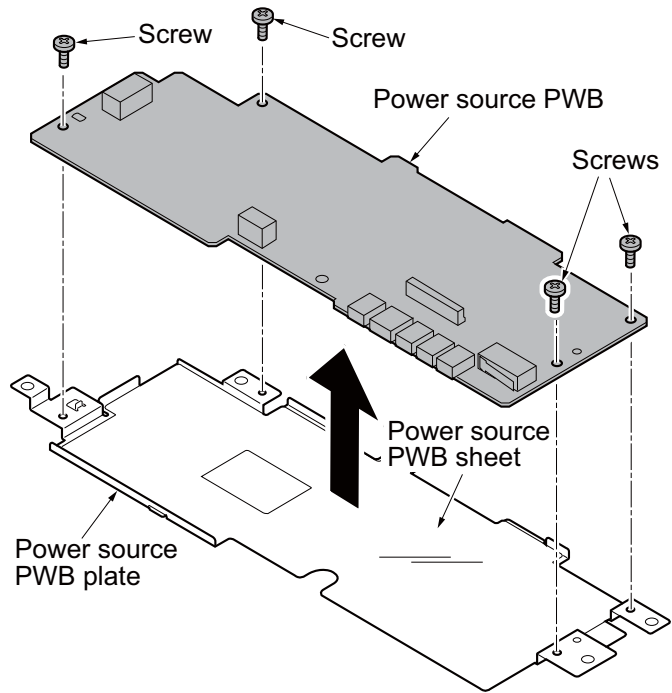

Figure 1-5-63

(3) Detaching and refitting the high voltage PWB

Procedure

1. Remove the developer unit (See page 1-5-27).
2. Remove the drum unit (See page 1-5-28).
3. Remove the cassette (See page 1-5-6).
4. Remove the left cover and right cover (See page 1-5-3).
5. Remove the power source PWB (See page 1-5-40).
6. Turn the machine with the front side up.
7. Remove the stopper.
8. Remove the DU holder.

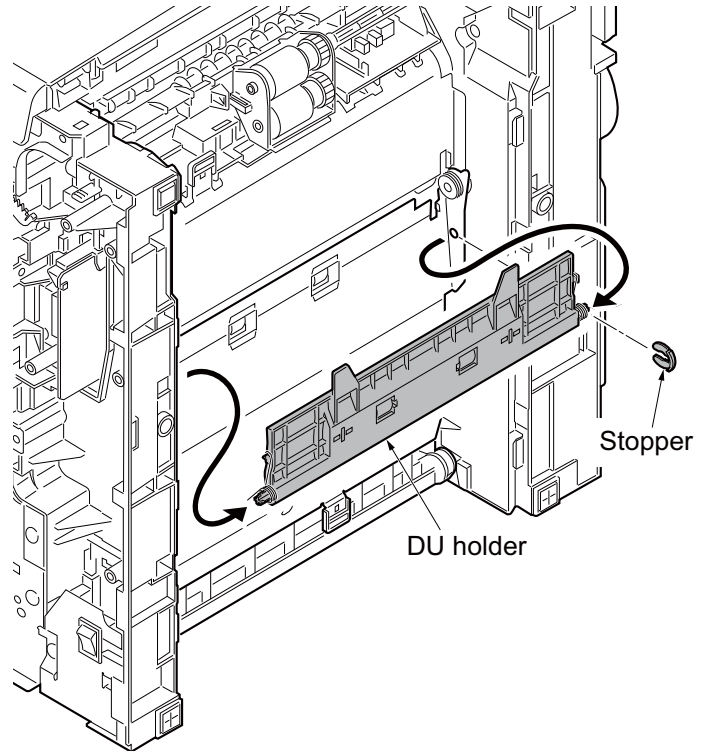

Figure 1-5-64

9. Pull the DU bush out.
10. Remove the DU cover assembly.

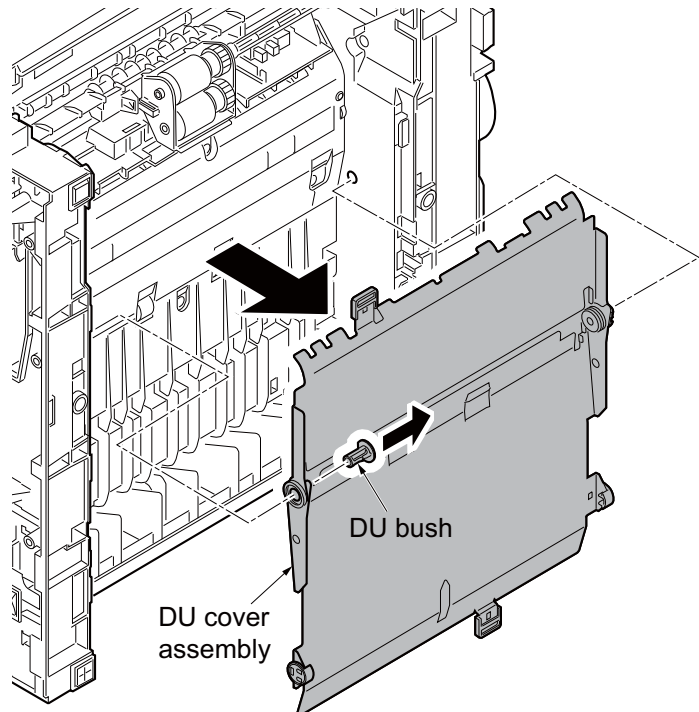

Figure 1-5-65

- 11. Remove four screws.
- 12. Unhook three hooks and then remove the lower base cover.

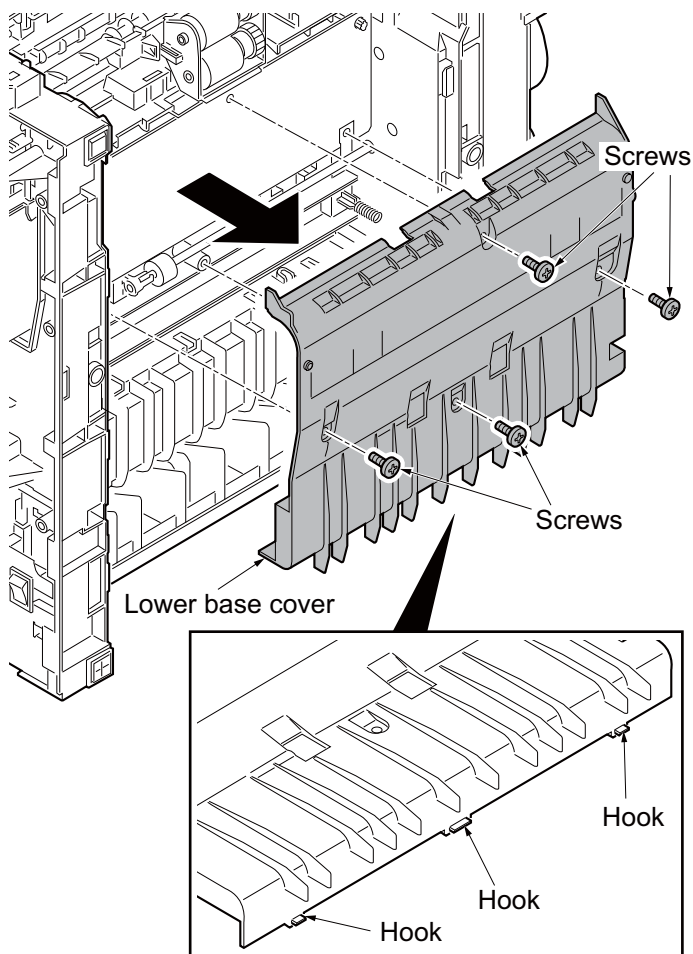

Figure 1-5-66

- 13. Remove the spring.
- 14. Remove the cassette pin.

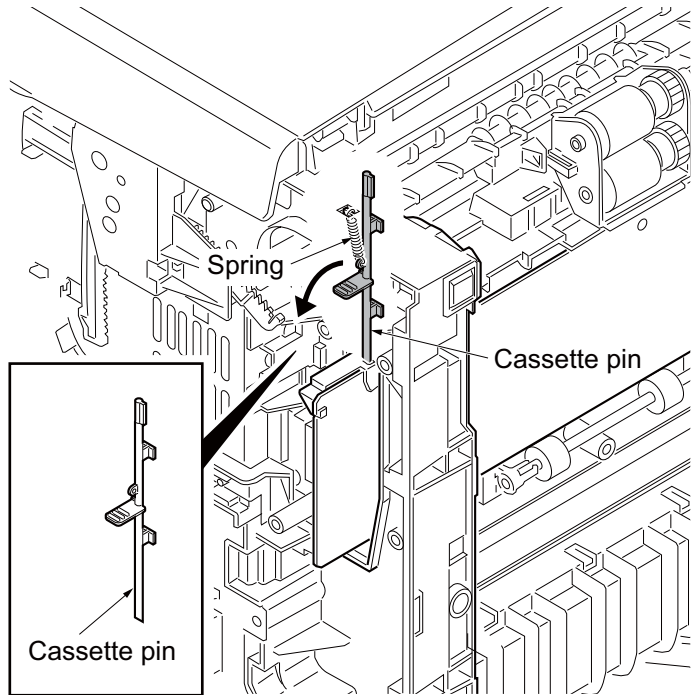

Figure 1-5-67

- 15. Remove two connectors and then remove the high voltage PWB.
- 16. Remove the cassette pin holder from the high voltage PWB.

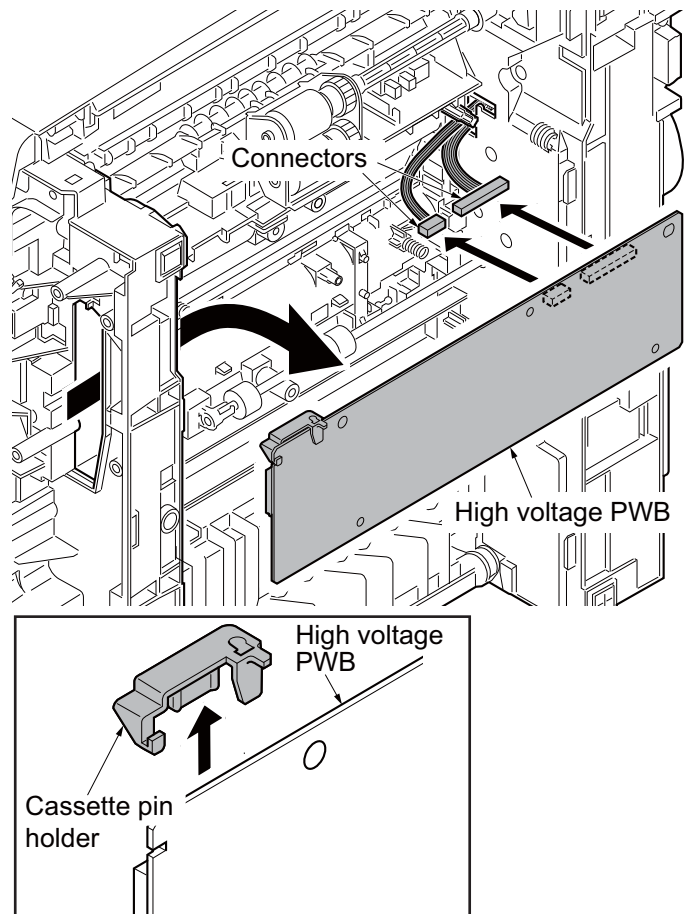

Figure 1-5-68

17. Check or replace the high voltage PWB and refit all the removed parts.

When refitting the high voltage PWB, be careful about following points.

- Position the ground plate so that it is atop the high voltage PWB.
- Each interface is firmly in contact with each spring.
- The bias contact pin must be installed in the specified position.
- The cassette pin must be inserted in the cassette pin holder.

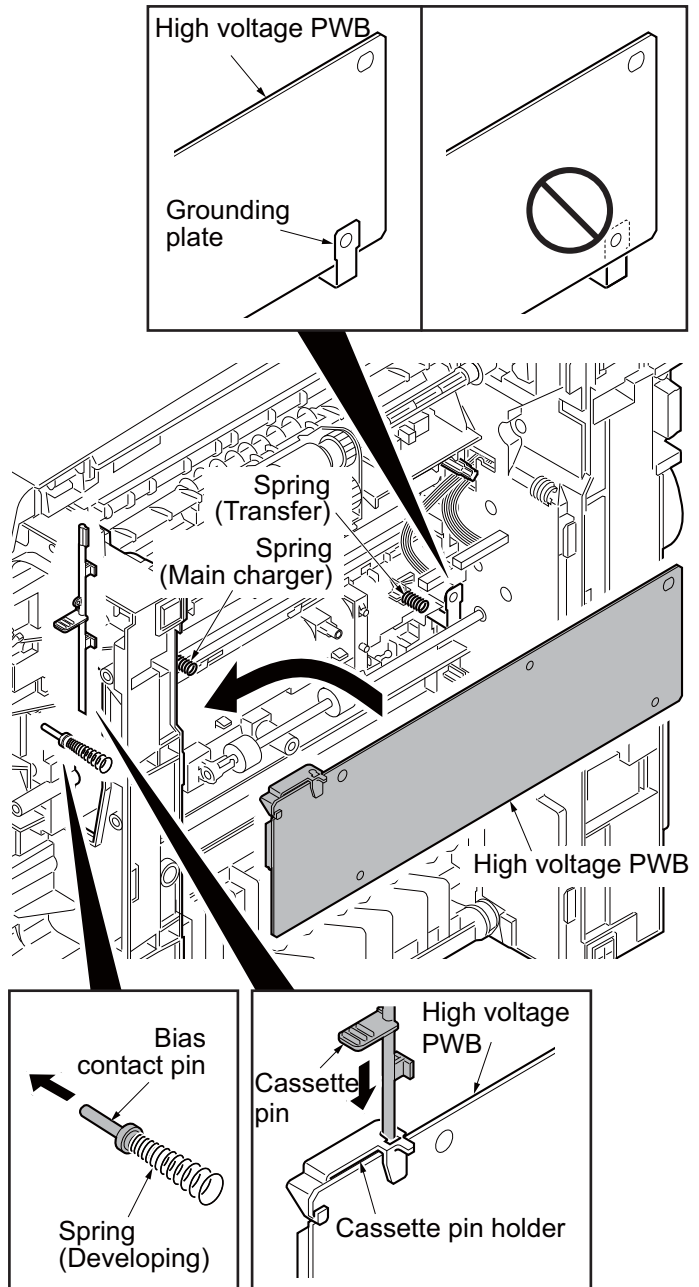

Figure 1-5-69

(4) Detaching and refitting the scanner PWB

Procedure

1. Remove the right cover (See page 1-5-3).
2. Remove six connectors and the FFC from the scanner PWB.

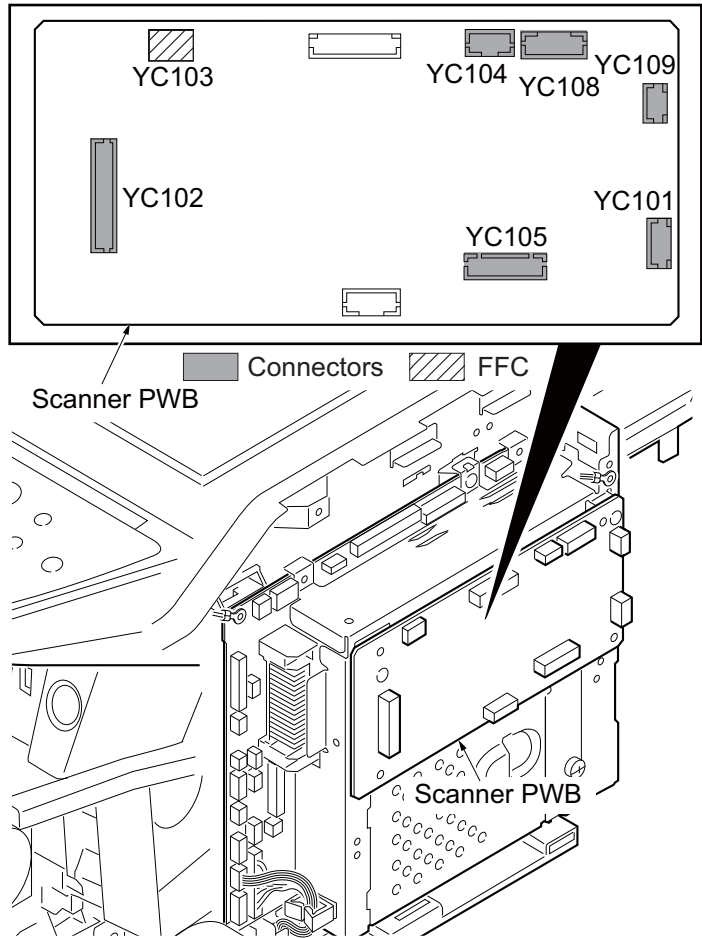

Figure 1-5-70

3. Remove four screws and then remove the scanner PWB.
4. Check or replace the scanner PWB and refit all the removed parts.

NOTE:

When the replacing the scanner PWB, perform following maintenance modes.

1. U425 Setting the target (see page 1-3-20)
2. U411 Adjusting the scanner automatically (see page 1-3-18)

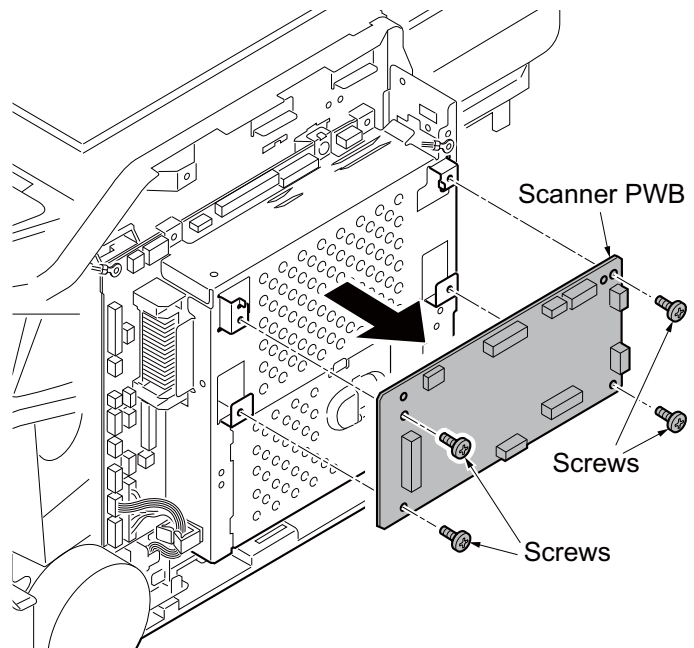

Figure 1-5-71

(5) Detaching and refitting the FAX control PWB

Procedure

1. Unhook the hook and then remove the controller box cover.

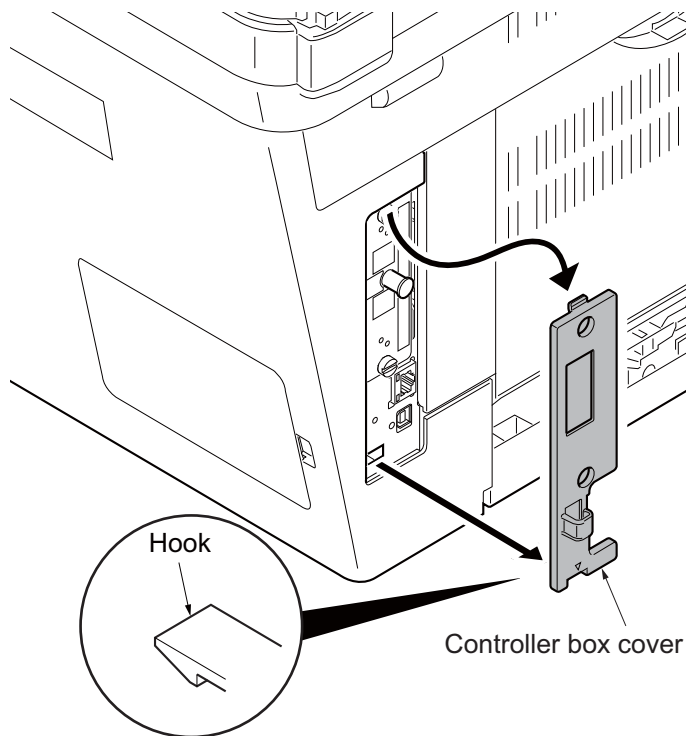

Figure 1-5-72

2. Remove two screws and then remove the FAX control PWB.
3. Check or replace the FAX control PWB and refit all the removed parts.

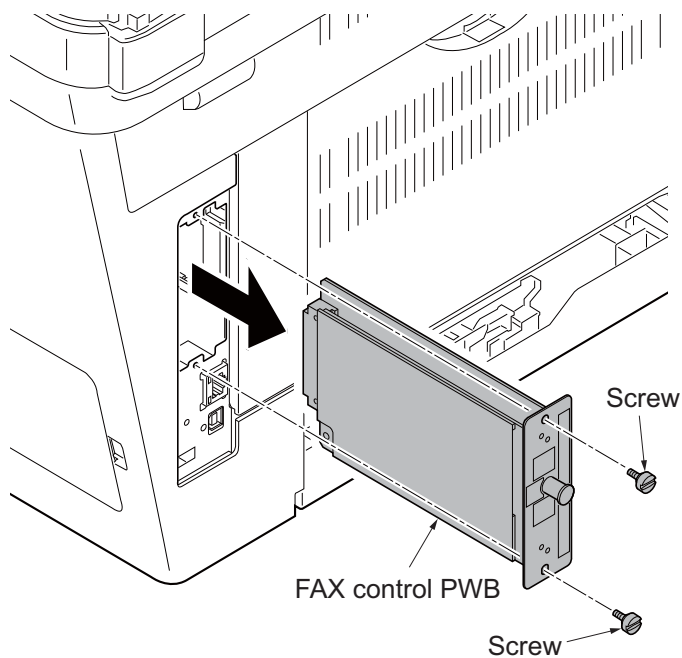

Figure 1-5-73

1-5-10 Others

(1) Detaching and refitting the main motor

Procedure

1. Remove the right cover (See page 1-5-3).
2. Remove the connector.
3. Remove the M3 screw and two M4 screws.
4. Remove the main motor.
5. Check or replace the main motor and refit all the removed parts.

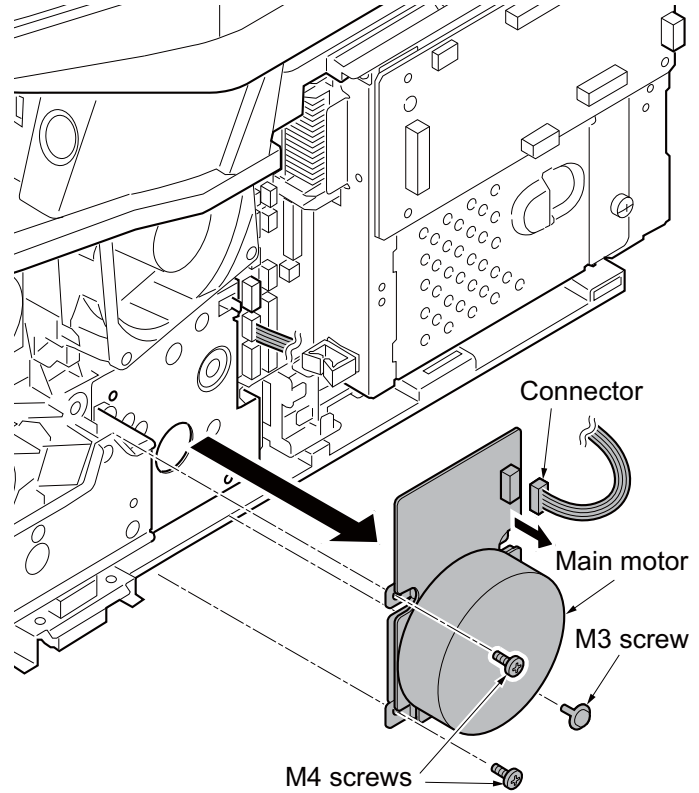

Figure 1-5-74

(2) Direction of installing the left cooling fan motor, right cooling fan motor and power source fan motor

When detaching or refitting a fan motor, be careful of the airflow direction (intake or exhaust).

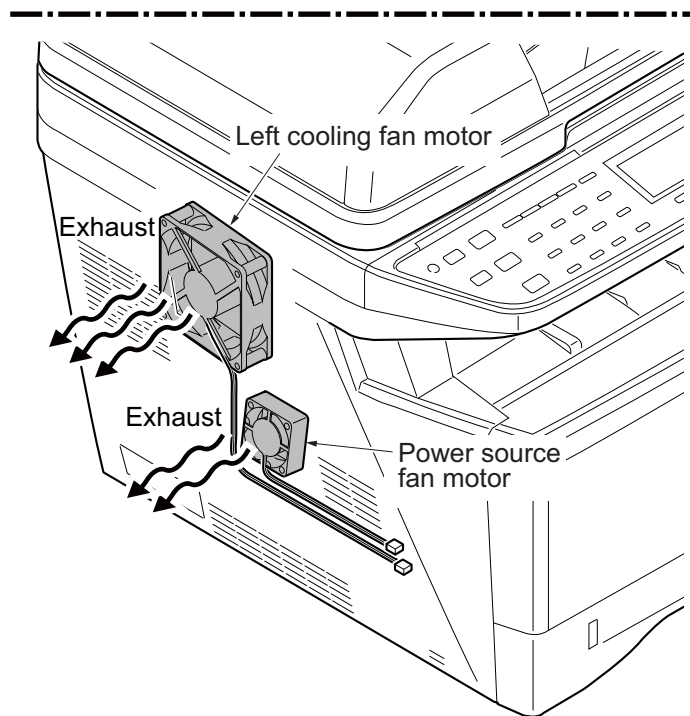
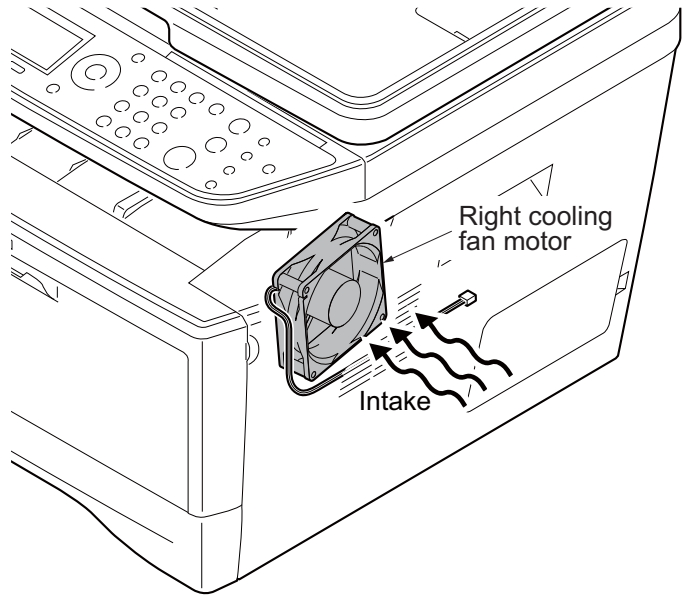

Figure 1-5-75

1-5-11 Document processor

(1) Detaching and refitting the DP rear cover and DP front cover

Procedure

1. Open the DP top cover.
2. Remove two screws.
3. Unhook the hook and then remove the DP rear cover.

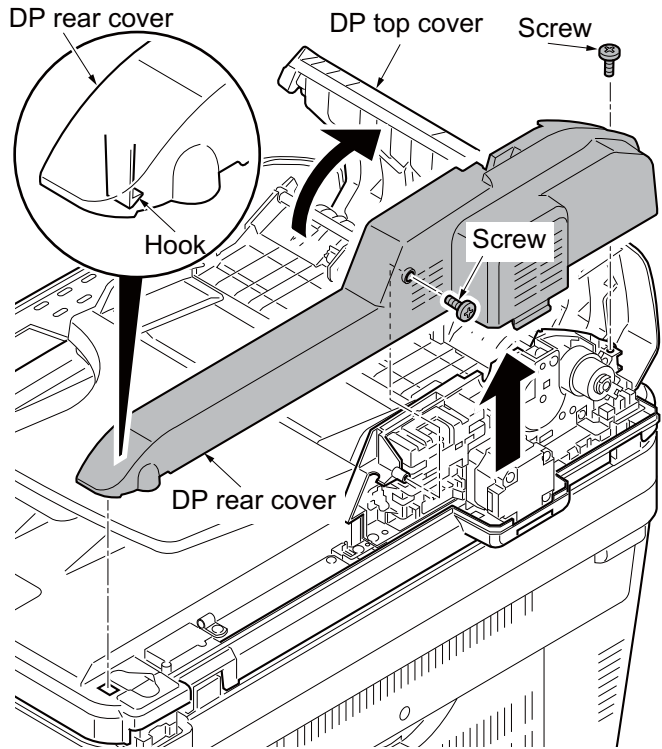

Figure 1-5-76

4. Unhook two hooks and then remove the DP front cover.

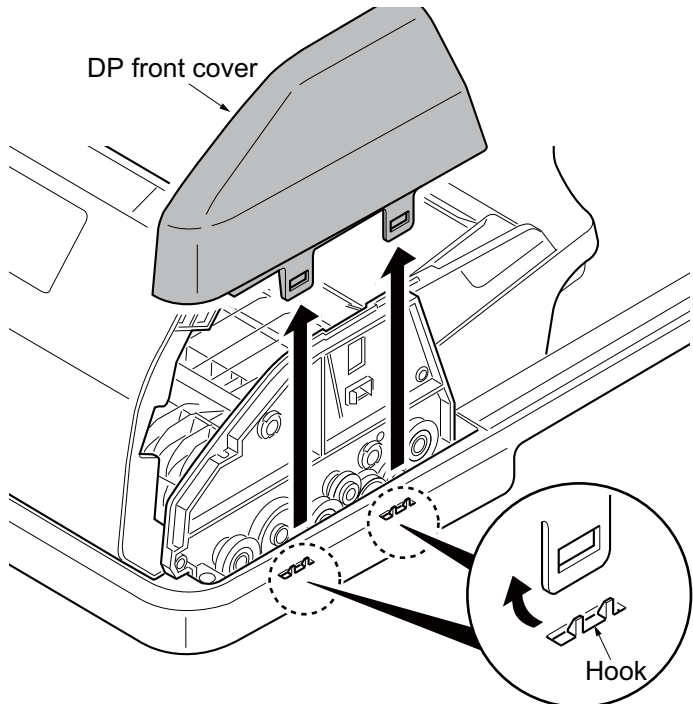

Figure 1-5-77

(2) Detaching and refitting the DP drive PWB

Follow the procedure below to check or replace the DP drive PWB.

Procedure

1. Remove the DP rear cover.
(See page 1-5-51).
2. Remove eight connectors from the DP drive PWB.
3. Remove the screw and then remove the DP drive PWB.
4. Check or replace the DP drive PWB.
Refit all the removed parts.

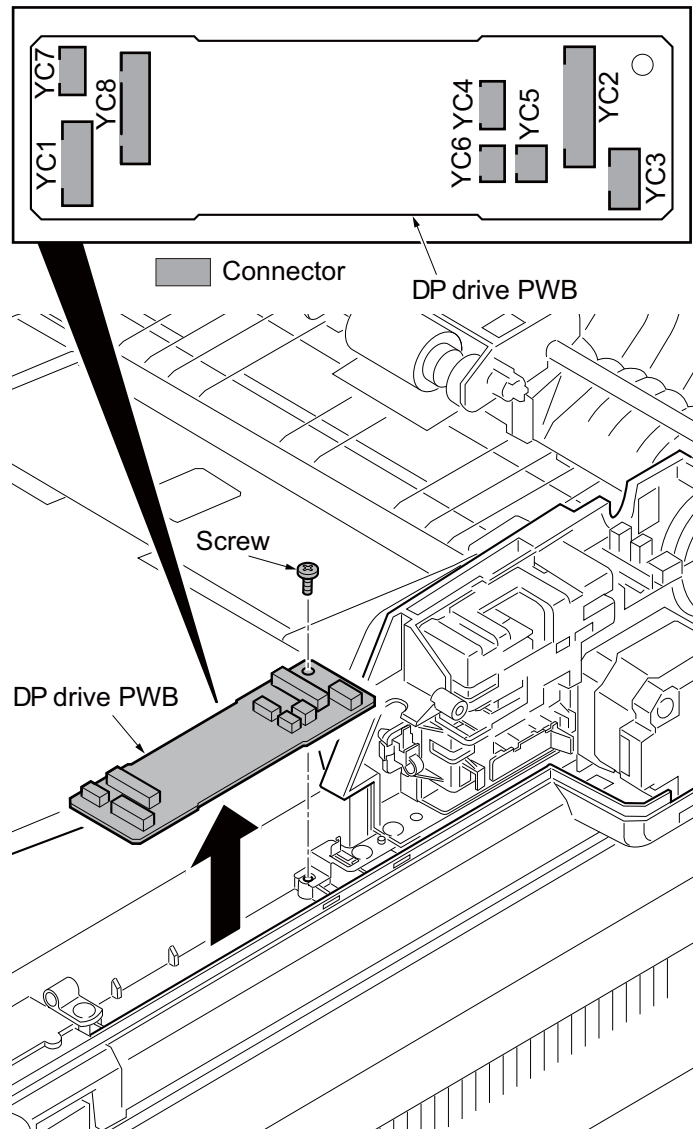

Figure 1-5-78

(3) Detaching and refitting the feed pulley and forwarding pulley

Follow the procedure below to clean or replace the feed pulley or forwarding pulley.

Procedure

1. Remove the DP rear cover and DP front cover (See page P.1-5-51).
2. Remove the stopper.
3. Remove the bush.

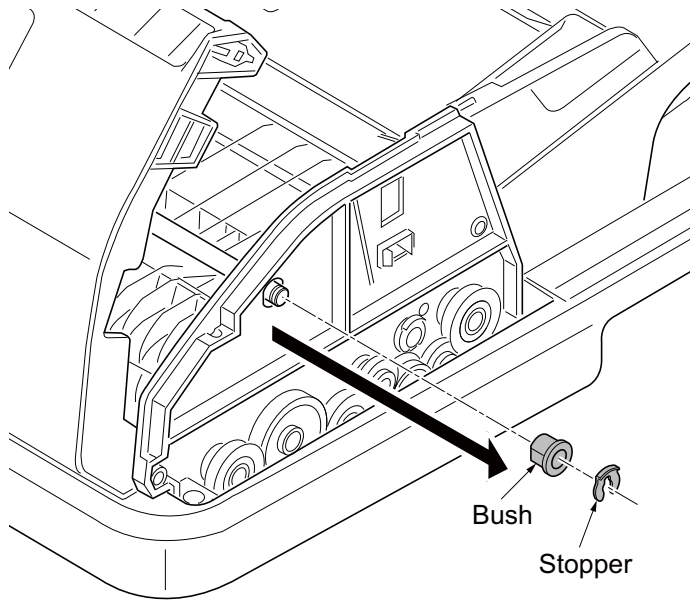

Figure 1-5-79

4. Remove the stopper A and then remove the DP paper feed clutch.
5. Remove the stopper B and then remove the PF collar, spring, spring collar S, pin and bush from the PF shaft.

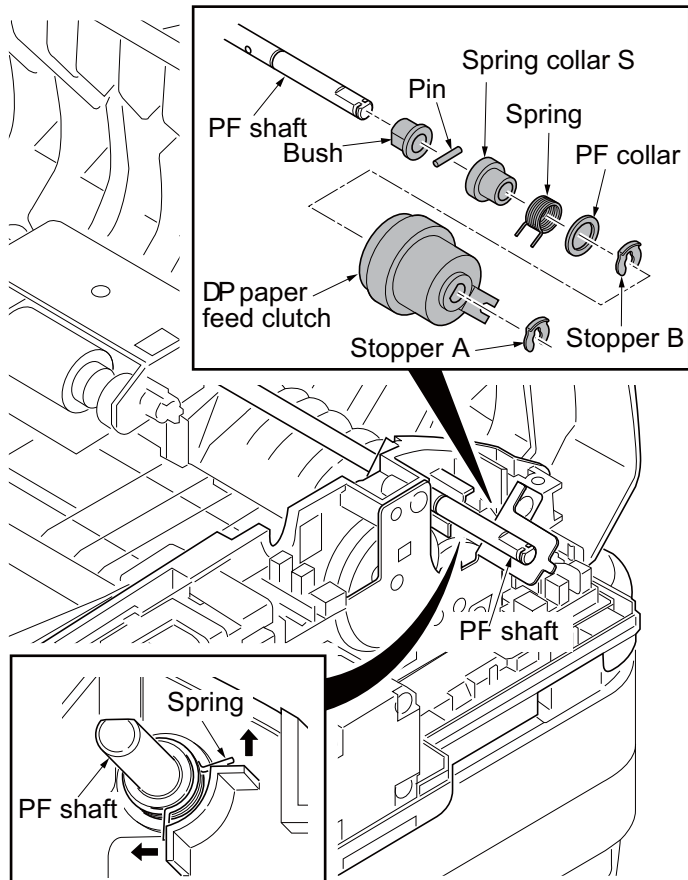

Figure 1-5-80

- Remove the forwarding pulley assembly.

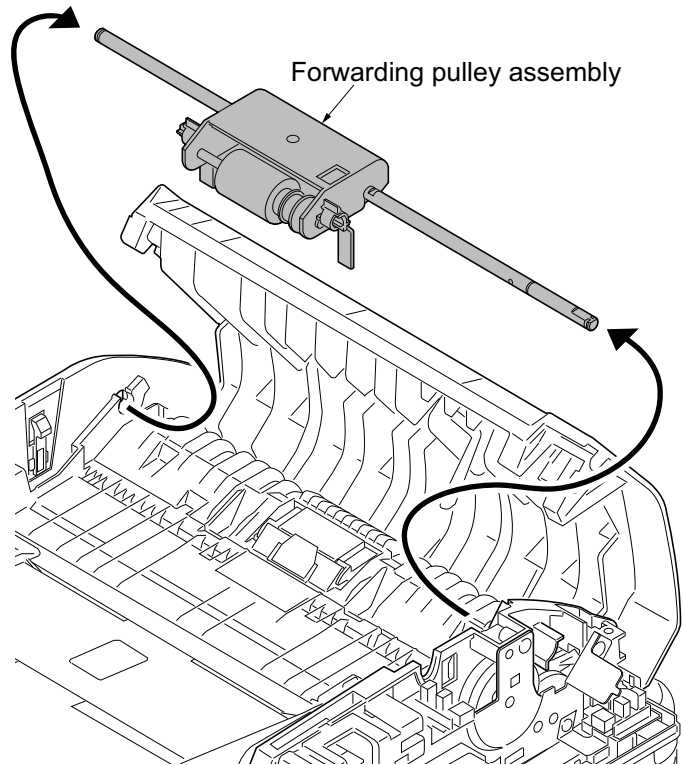

Figure 1-5-81

Detaching the feed pulley

- Remove the stopper A.
- Remove the feed pulley assembly from the LF holder.
- Remove the stopper B.
- Remove the PF collar, spring, spring collar S and pin from the PF shaft.
- Remove the feed pulley, one-way clutch, PF pulley gear and pin from the PF shaft.

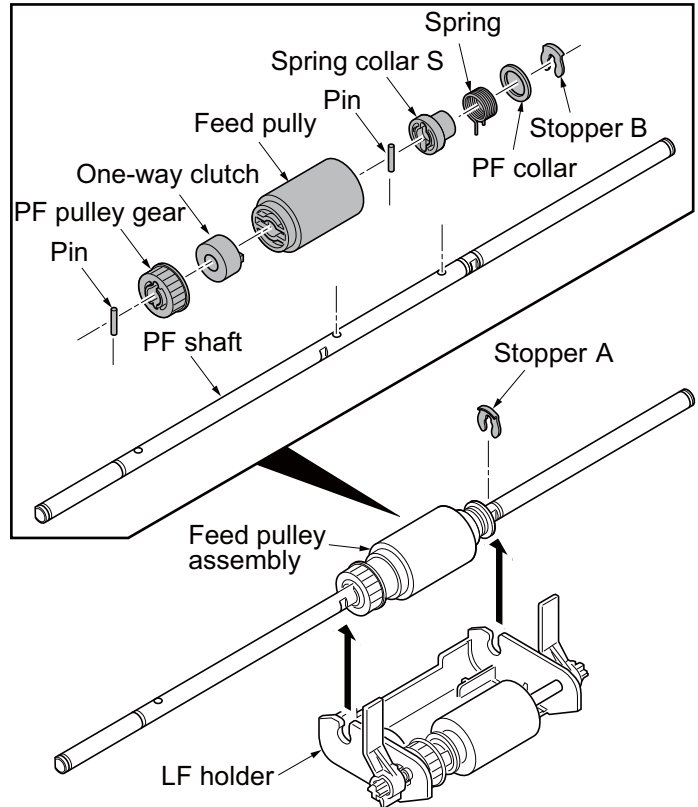
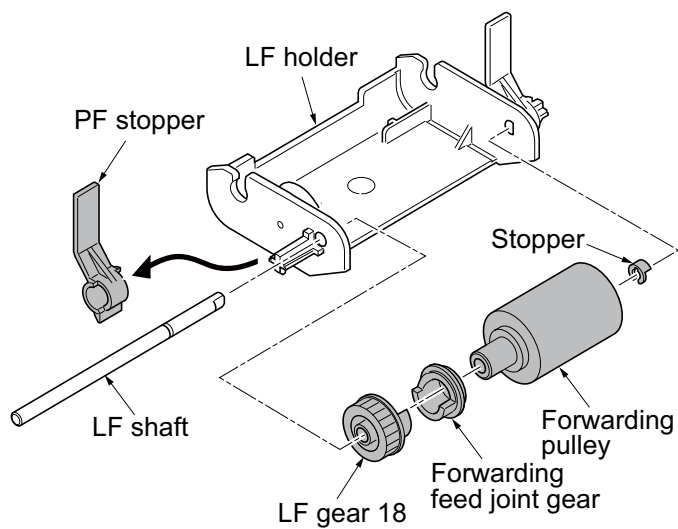

Figure 1-5-82

Detaching the forwarding pulley

12. Remove the PF stopper from the LF holder.
 13. Remove the stopper.
 14. Pull out the LF shaft and then remove the LF gear 18, forwarding feed joint gear and forwarding pulley.
 15. Clean or replace the feed pulley and forwarding pulley.
- Refit all the removed parts.

**Figure 1-5-83**

(4) Detaching and refitting the separation pad assembly

Follow the procedure below to clean or replace the separation pad assembly.

Procedure

1. Remove the forwarding pulley assembly (See page P.1-5-53).
 2. Remove the separation pad assembly.
 3. Clean or replace the separation pad assembly.
- Refit all the removed parts.

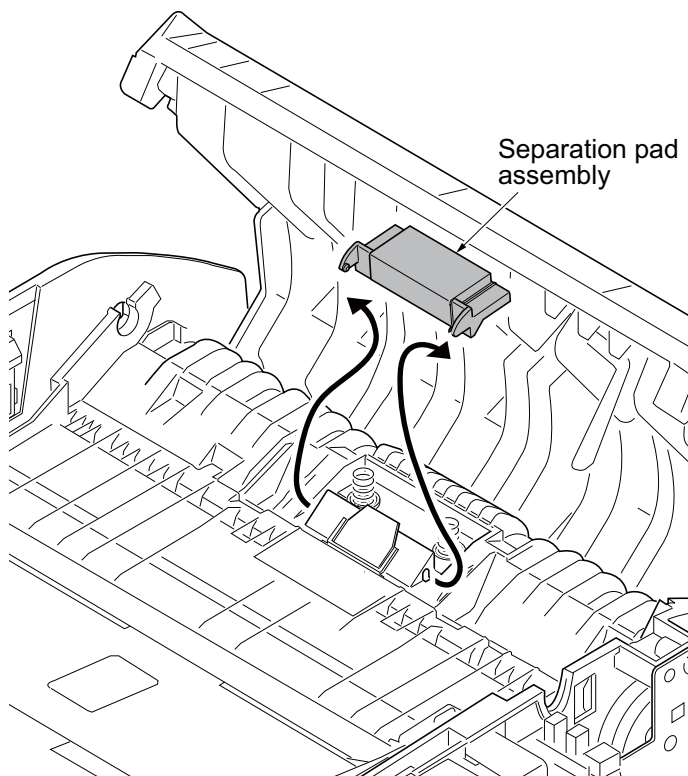

Figure 1-5-84

1-6-1 Upgrading the firmware

Follow the procedure below to upgrade the firmware of control PWB (main controller and engine) and scanner PWB.

Preparation

Extract the file that has the download firmware and put them in the USB Memory.

Procedure

1. Turn ON the power switch and confirm if the screen shows "Ready to print" then, turn OFF the power switch.
2. Insert USB memory that has the firmware in the USB memory slot.
3. Turn ON the power switch.
4. About 40 seconds later, "FW-Update" will be displayed and blinking the memory LED (this shows to start the download).
5. Display the software that now upgrading (5 minutes).

"FW- Update [CTRL]"

"[ENGN]"

"[SCAN]"

6. Display the completion of the upgrade (Memory LED is ON condition).
7. Cut the power supply by pulling out the power cable and remove the USB memory.

* : After the print engine farm is downloaded, it is not possible to turn it off with the power switch.

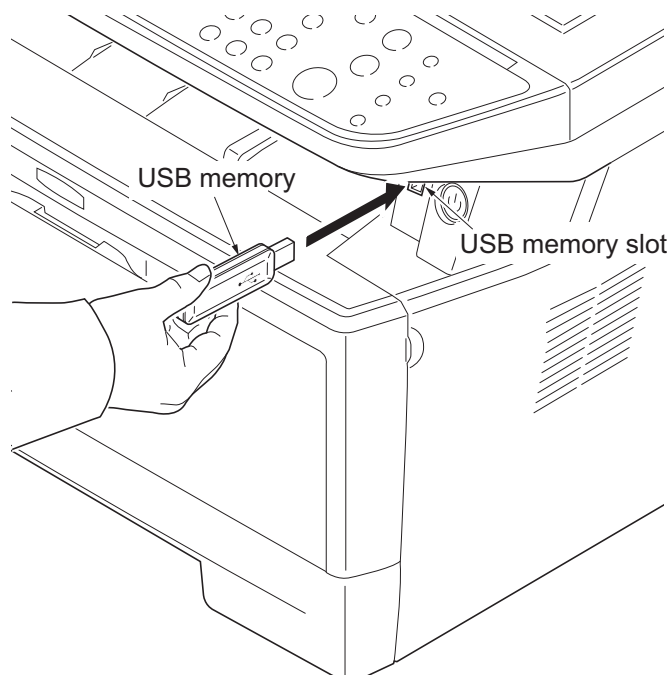

Figure 1-6-1

Check the result of the version up

1. Output the service status by the U000 and confirm the firmware version.

1-6-2 Remarks on control PWB replacement

When replacing the control PWB, remove the EEPROM (U17) from the control PWB that has been removed and then reattach it to the new control PWB.

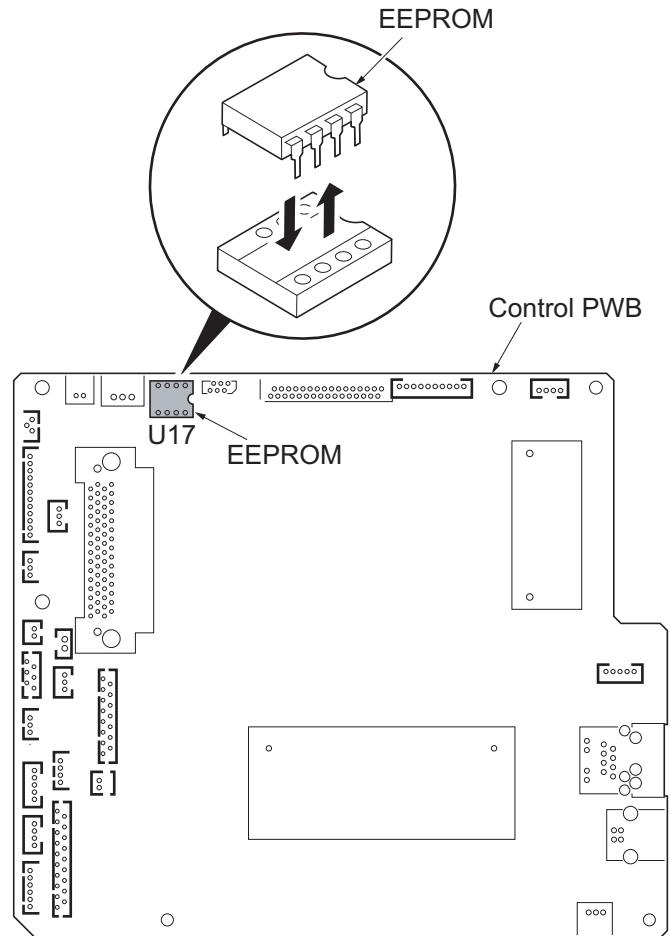

Figure 1-6-2

Detaching of EEPROM

1. The flat screwdriver is inserted between EEPROM and socket.
2. Detach it little by little right and left and alternately while noting the transformation and the damage of the pin.

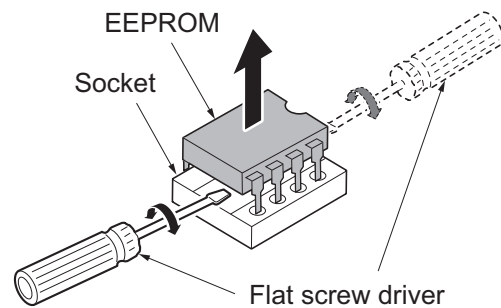

Figure 1-6-3

2-1-1 Paper feed/conveying section

Paper feed/conveying section consists of the paper feed unit that feeds paper from the cassette and the MP tray paper feed unit that feeds paper from the MP tray, and the paper conveying section that conveys the fed paper to the transfer/separation section.

(1) Cassette paper feed section

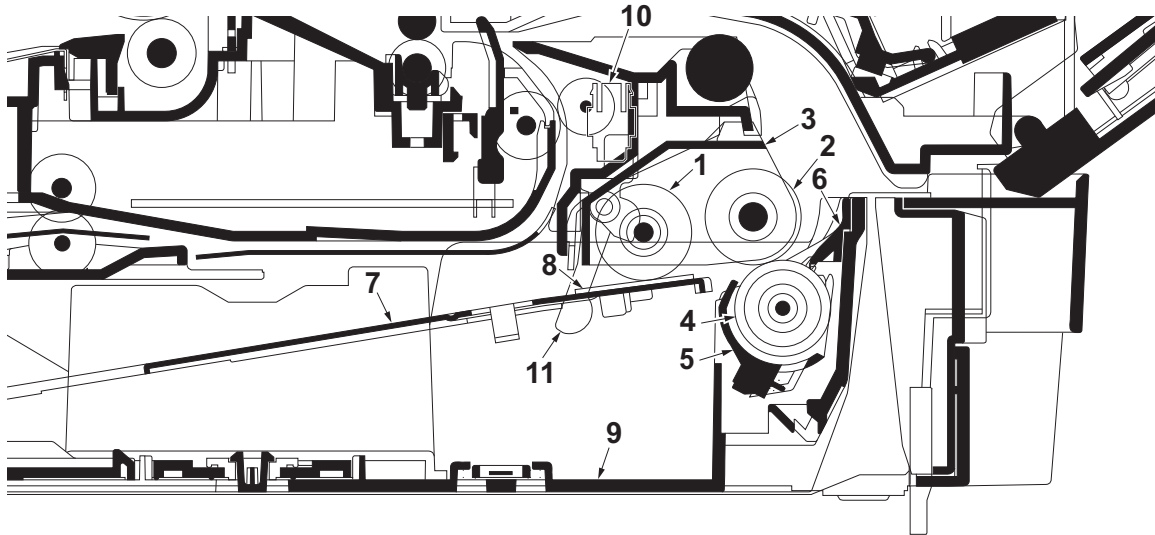

Figure 2-1-1 Cassette paper feed section

- | | |
|----------------------|-----------------------------|
| 1. Pickup roller | 7. Bottom plate |
| 2. Paper feed roller | 8. Bottom pad |
| 3. Feed holder | 9. Cassette base |
| 4. Retard roller | 10. Paper sensor |
| 5. Retard holder | 11. Actuator (paper sensor) |
| 6. Retard guide | |

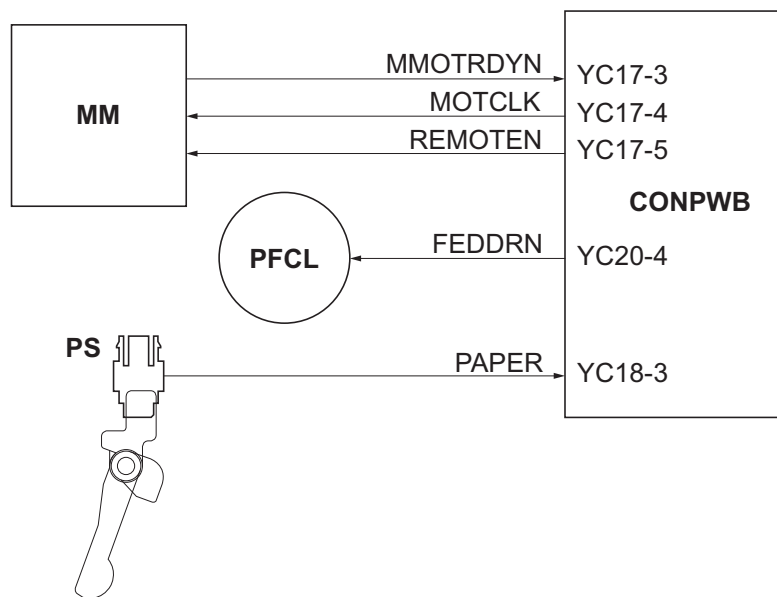

Figure 2-1-2 Cassette paper feed section block diagram

(2) MP tray paper feed section

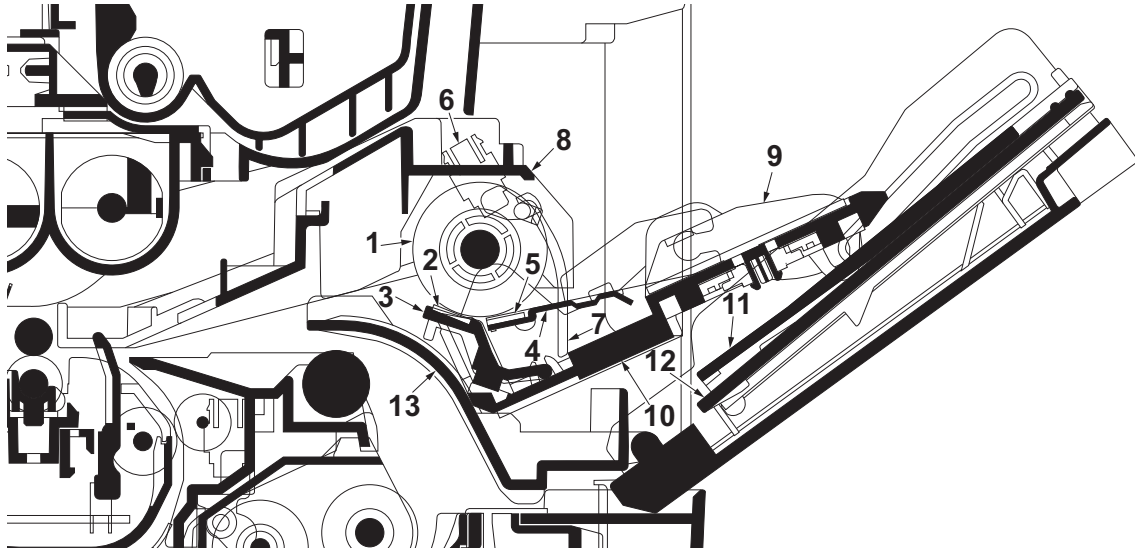

Figure 2-1-3 MP tray paper feed section

- | | |
|-------------------------------|---------------------|
| 1. MP paper feed roller | 8. MPF frame |
| 2. MPF separation pad | 9. MPF guide R/L |
| 3. MPF separator | 10. MPF base |
| 4. MPF bottom plate | 11. MPF middle tray |
| 5. MPF friction pad | 12. MPF upper tray |
| 6. MP paper sensor | 13. MPF turn guide |
| 7. Actuator (MP paper sensor) | |

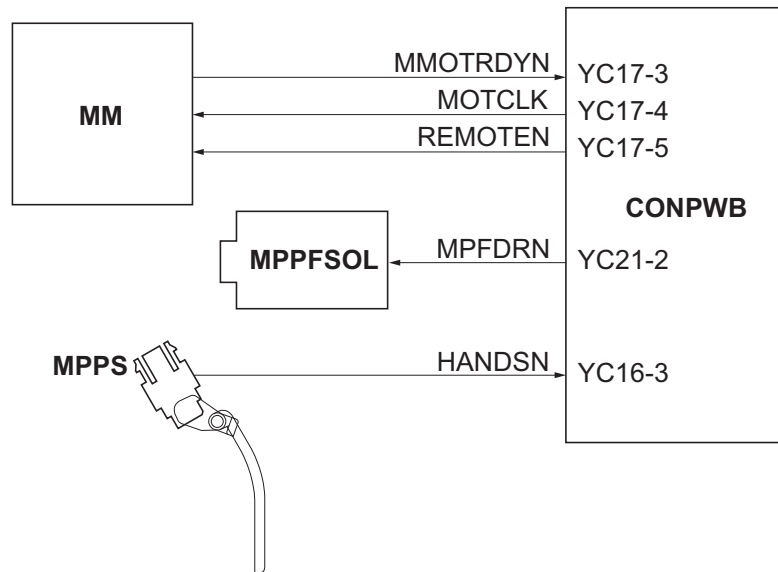

Figure 2-1-4 MP tray paper feed section block diagram

(3) Paper conveying section

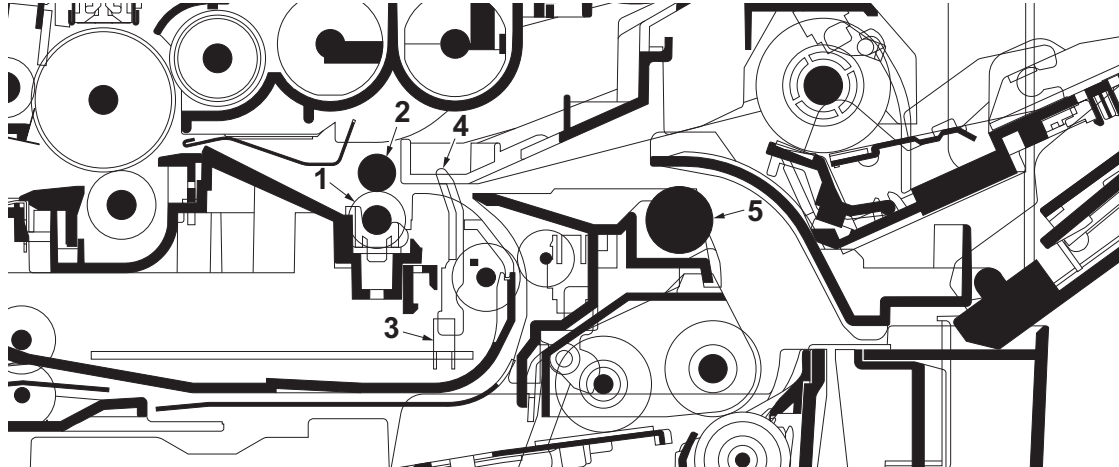

Figure 2-1-5 Paper conveying section

- 1. Lower registration roller
- 2. Upper registration roller
- 3. Registration sensor
- 4. Actuator (registration sensor)
- 5. Feed pulley

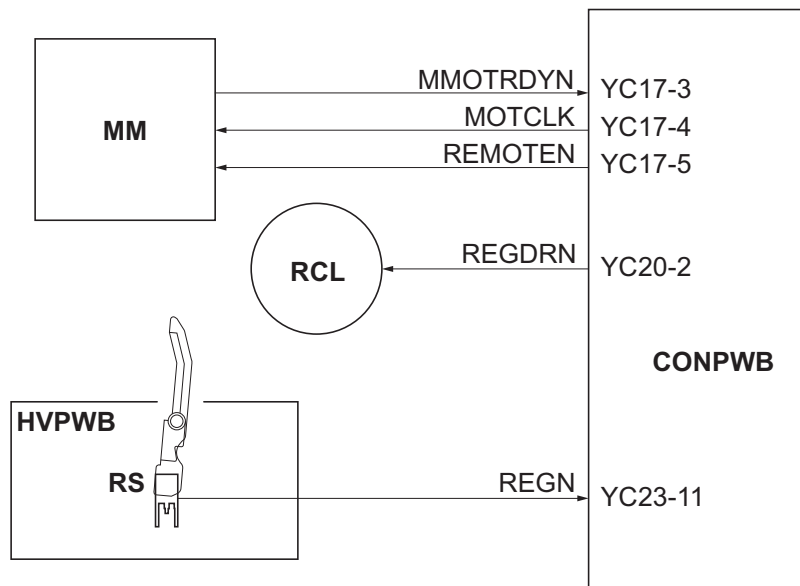

Figure 2-1-6 Paper conveying section block diagram

2-1-2 Drum section

(1) Drum section

The durable layer of organic photoconductor (OPC) is coated over the aluminum cylinder base. The OPC tend to reduce its own electrical conductance when exposed to light. After a cyclic process of charging, exposure, and development, the electrostatic image is constituted over the OPC layer.

Since the OPC is materialized by resin, it is susceptible to damage caused by sharp edges such as a screw-driver, etc., resulting in a print quality problem. Also, finger prints can cause deterioration of the OPC layer, therefore, the drum (in the drum unit) must be handled with care. Substances like water, alcohol, organic solvent, etc., should be strictly avoided.

As with all other OPC drums, the exposure to a strong light source for a prolonged period can cause a print quality problem. The limit is approximately 500 lux for less than five minutes. If the drum (drum unit) remains removed from the machine, it should be stored in a cool, dark place.

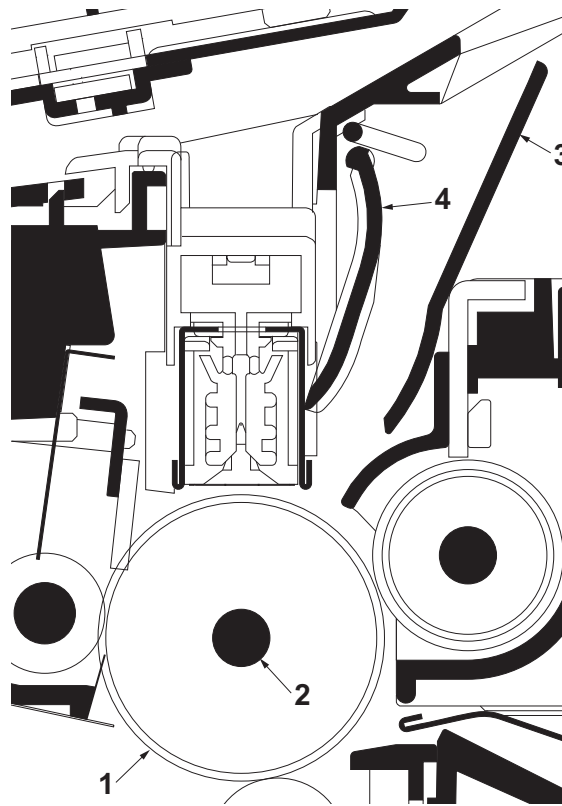

Figure 2-1-7 Drum unit

1. Drum
2. Drum shaft
3. Drum cover A
4. Drum cover B

(2) Main charger unit

As the drum rotates in a “clean (neutral)” state, its photoconductive layer is given a uniform, positive (+) corona charge dispersed by the main charger wire. Due to high-voltage scorotron charging, the charging wire can get contaminated by oxidization after a long run. Therefore, the charger wire must be cleaned at a specific interval. Cleaning the charging wire prevents print quality problems such as black streaks.

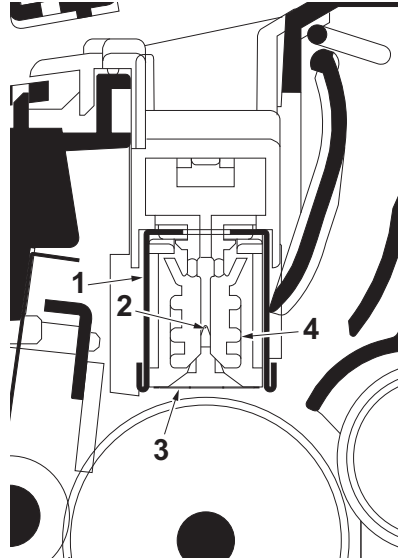

Figure 2-1-8 Main charger unit

- 1. Main charger shield
- 2. Main charger wire
- 3. Main charger grid
- 4. Main charger wire cleaner

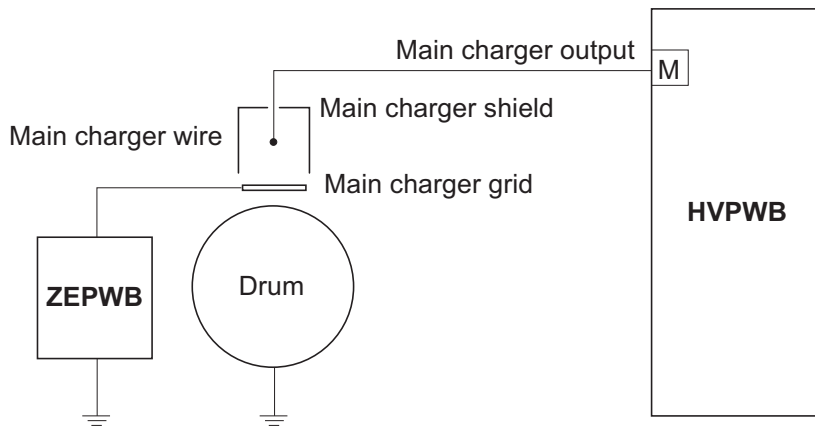

Figure 2-1-9 Drum unit and main charger unit block diagram

2-1-3 Optical section

(1) Scanner unit

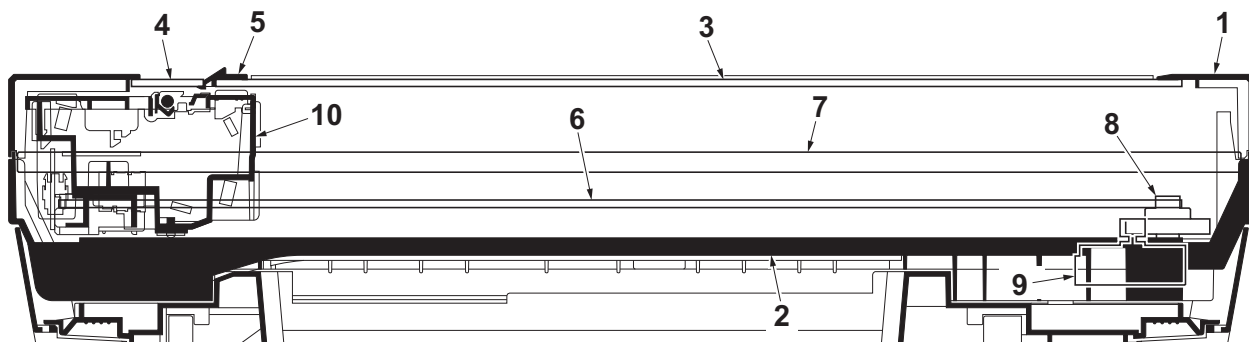

Figure 2-1-10 Scanner unit

- | | |
|-------------------------|------------------------------|
| 1. ISU top frame | 6. ISU belt |
| 2. ISU bottom frame | 7. ISU shaft |
| 3. Contact glass | 8. ISU gear 63/32 |
| 4. DP contact glass | 9. ISU motor |
| 5. Size indicator plate | 10. Image scanner unit (ISU) |

(2) Image scanner unit (ISU)

The original image is illuminated by the LED and scanned by the CCD image sensor in the CCD PWB (CCD-PWB) via the four mirrors and ISU lens, the reflected light being converted to an electrical signal.

If a document processor (DP) is used, the image scanner unit stops at the position of the DP contact glass and scans sequentially one row of the image on the original in synchronization with the moving timing of the original in the sub scan direction by driving the DP.

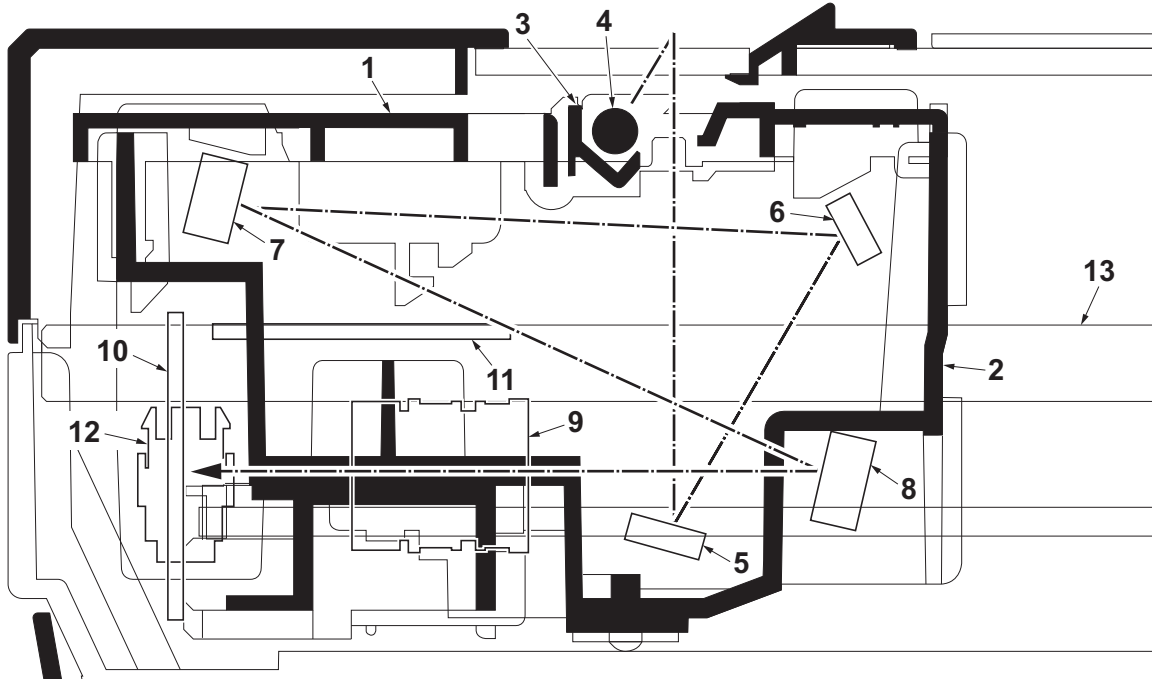

Figure 2-1-11 Image scanner unit (ISU)

- | | |
|-------------------------|--------------------------------|
| 1. Lamp mount | 8. Mirror D |
| 2. ISU housing | 9. ISU lens |
| 3. ISU reflector | 10. CCD PWB (CCDPWB) |
| 4. Transparent material | 11. LED drive PWB (LEDDRPWB) |
| 5. Mirror A | 12. Home position sensor (HPS) |
| 6. Mirror B | 13. ISU shaft |
| 7. Mirror C | |

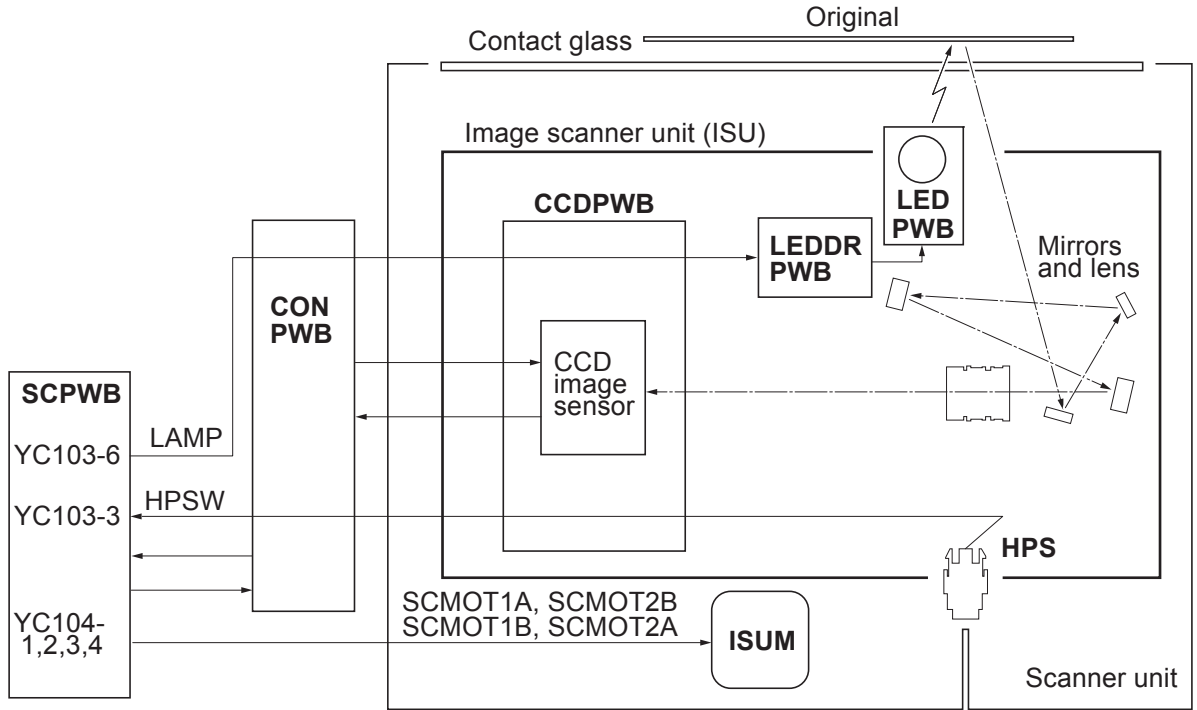

Figure 2-1-12 Scanner unit block diagram

(3) Laser scanner unit

The charged surface of the drum is then scanned by the laser beam from the laser scanner unit. The laser beam (780 nm wavelength) beam is dispersed as the polygon motor revolves to reflect the laser beam over the drum. Various lenses and mirror are housed in the laser scanner unit, adjust the diameter of the laser beam, and focalize it at the drum surface.

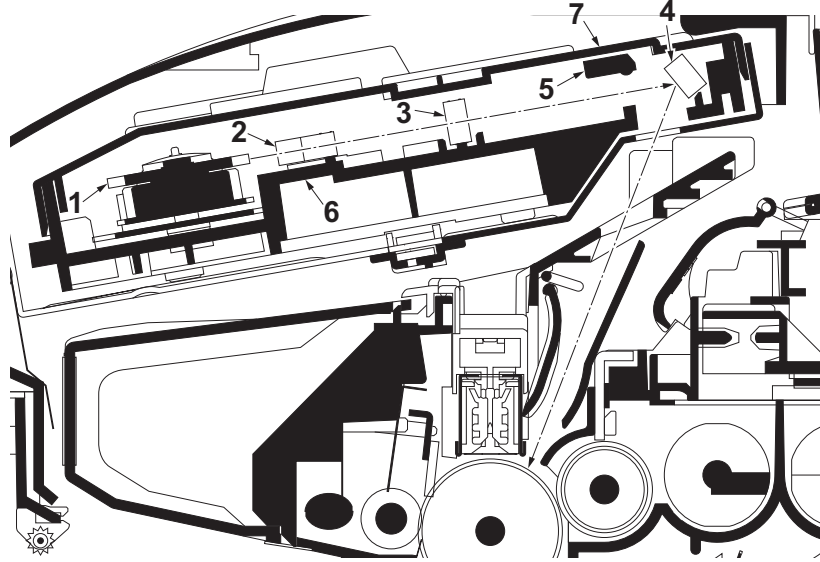

Figure 2-1-13 Laser scanner unit

1. Polygon motor (mirror)
2. F- θ lens
3. F- θ lens
4. LSU mirror
5. LSU shutter
6. LSU frame
7. LSU cover

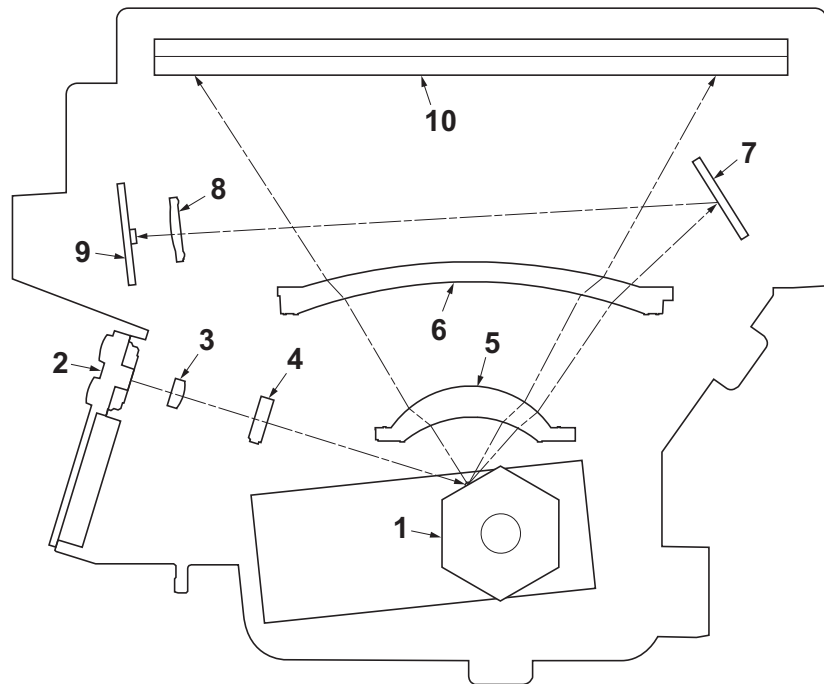

Figure 2-1-14 Laser scanner unit

- | | |
|---------------------------|------------------------------------|
| 1. Polygon motor (mirror) | 6. F- θ lens |
| 2. Laser diode (APC PWB) | 7. PD mirror |
| 3. Collimator lens | 8. SOS lens |
| 4. Cylindrical lens | 9. Pin photo diode sensor (PD PWB) |
| 5. F- θ lens | 10. LSU mirror |

2-1-4 Developing section

The latent image constituted on the drum is developed into a visible image. The developing roller contains a 3-pole (S-NS) magnet roller and an aluminum cylinder rotating around the magnet roller. Toner attracts to the magnet sleeve since it is powdery ink made of black resin bound to iron particles. Developing blade, magnetized by magnet, is positioned approximately 0.3 mm above the magnet sleeve to constitute a smooth layer of toner in accordance with the magnet sleeve revolution.

The developing roller is applied with the AC-weighted, positive DC power source. Toner on the magnet sleeve is given a positive charge. The positively charged toner is then attracted to the areas of the drum which was exposed to the laser light. (The gap between the drum and the magnet sleeve is approximately 0.32 mm.) The non-exposed areas of the drum repel the positively charged toner as these areas maintain the positive charge.

The developing roller is also AC-biased to ensure contrast in yielding by compensating the toner's attraction and repelling action during development.

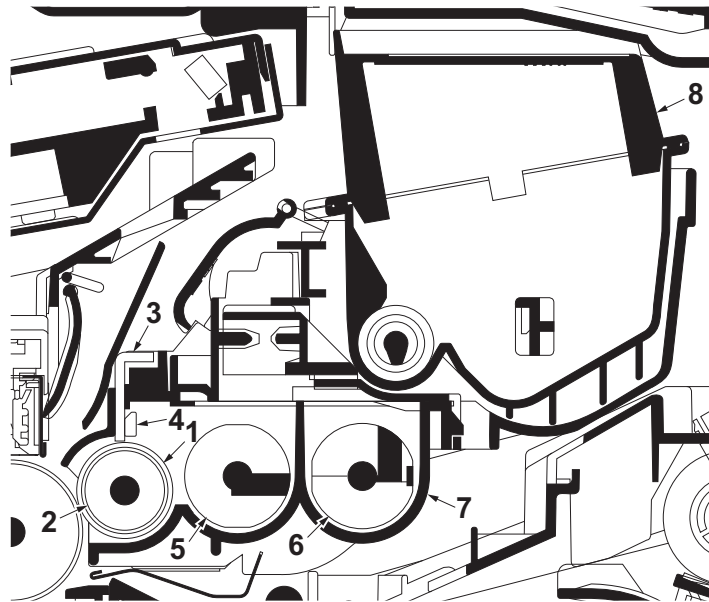

Figure 2-1-15 Developing unit and toner container

- | | |
|---------------------|--------------------|
| 1. Magnet sleeve | 5. DLP screw A |
| 2. Magnet roller | 6. DLP screw B |
| 3. Developing blade | 7. DLP case |
| 4. Blade magnet | 8. Toner container |

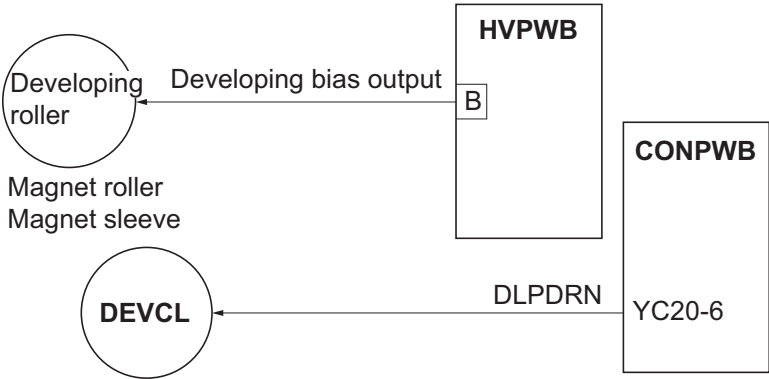

Figure 2-1-16 Developing section block diagram

2-1-5 Transfer/separation section

The transfer/separation section consists of the transfer roller, discharge electrode and paper chute guide. A high voltage generated by the high voltage PWB is applied to the transfer roller for transfer charging. Paper after transfer is separated from the drum.

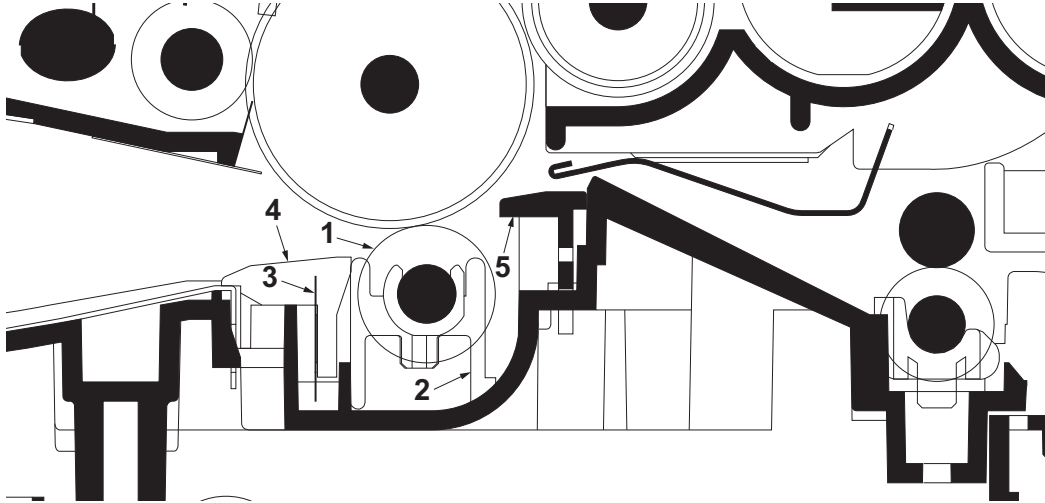

Figure 2-1-17 Transfer/separation section

1. Transfer roller
2. Transfer bushes
3. Discharge electrode
4. DC brush holder
5. Paper chute guide

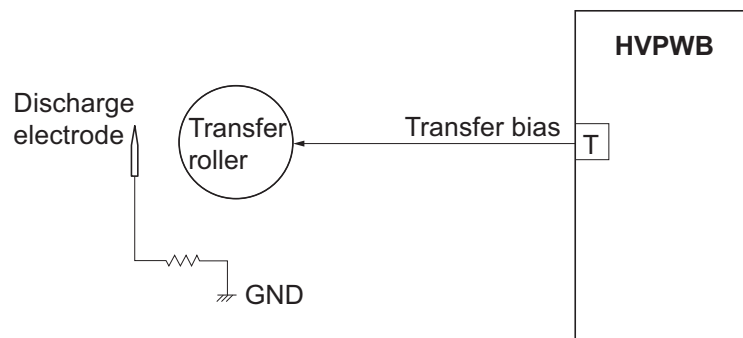

Figure 2-1-18 Transfer/separation section block diagram

2-1-6 Cleaning section

After the transferring process, the drum needs to be physically cleaned of toner which is residual after the development process. The cleaning blade is constantly pressed against the drum and scrapes the residual toner off to the sweep roller.

The waste toner is collected at the output end of the sweep roller and sent back to the toner container, into the waste toner reservoir.

After the drum is physically cleaned, it then must be cleaned to the electrically neutral state. This is necessary to erase any residual positive charge, ready to accept the uniform charge for the next print process. The residual charge is canceled by exposing the drum to the light emitted from the cleaning lamp (PWB). This lowers the electrical conductivity of the drum surface making the residual charge on the drum surface escape to the ground.

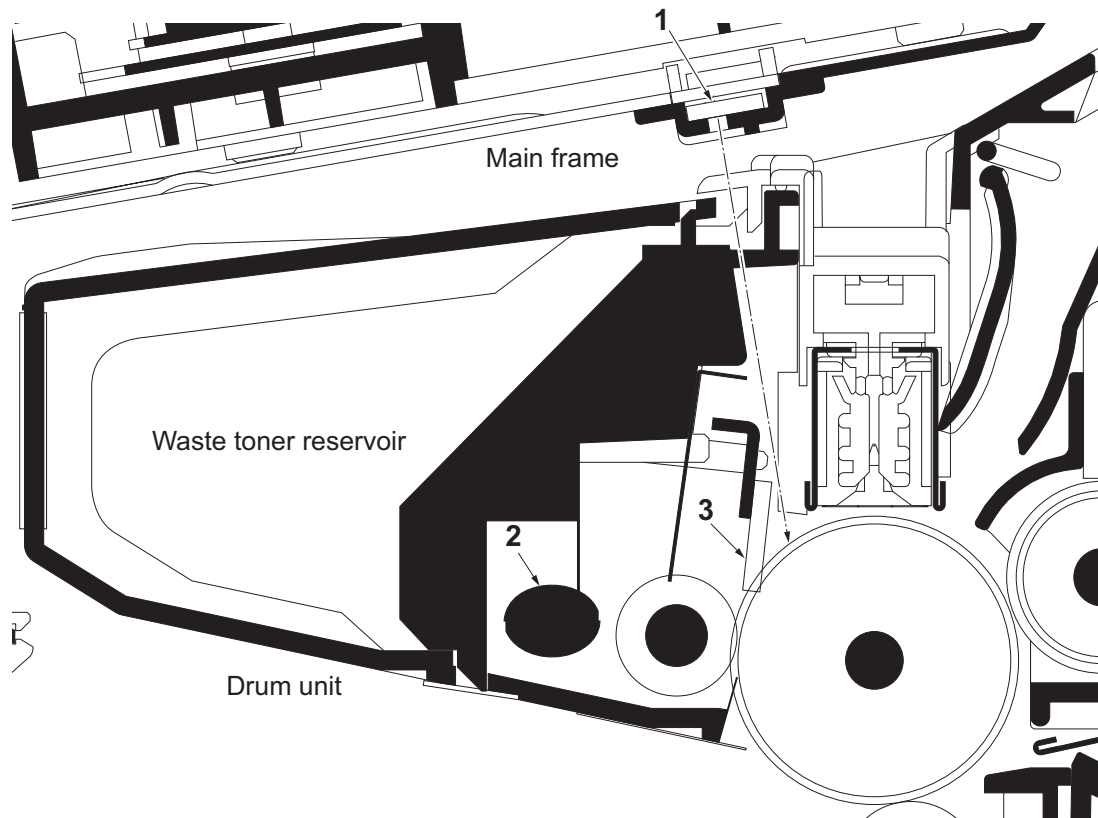

Figure 2-1-19 Cleaning section

1. Cleaning lamp (PWB)
2. Sweep roller
3. Cleaning blade

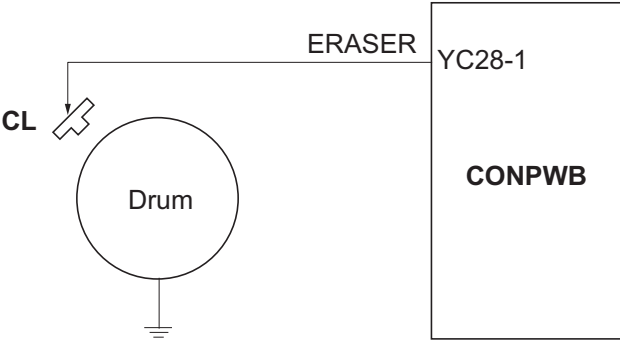

Figure 2-1-20 Cleaning section block diagram

2-1-7 Fuser section

The toner on the paper is molten and pressed into the paper as it passes between the heat roller and the press roller in the fuser unit. The heat roller has a heater inside which continuously turns on and off by the fuser thermistor to maintain the constant temperature onto the heat roller surface. The heat roller is resin coated by fluorin to prevent toner from accumulating on the roller after a long run. Care must be taken while handling the heat roller not to scratch the roller surface as doing so may result in print problems. Fuser temperature is optimized to the paper type. The heat roller has four separators (claws) which are continuously in contact with its surface. These separators (claws) prevent the paper on which toner has been fused from being wound around the heat roller causing paper jam. The press roller is made of the heat-resistant silicon rubber. This roller is used to strongly press the paper towards the heat roller by means of press springs. The temperature of the heat roller is constantly monitored by the control PWB using the fuser thermistor. Should the temperature of the heat roller exceed the predetermined value, the fuser thermal cutout is activated to effectively disconnect the heater from power.

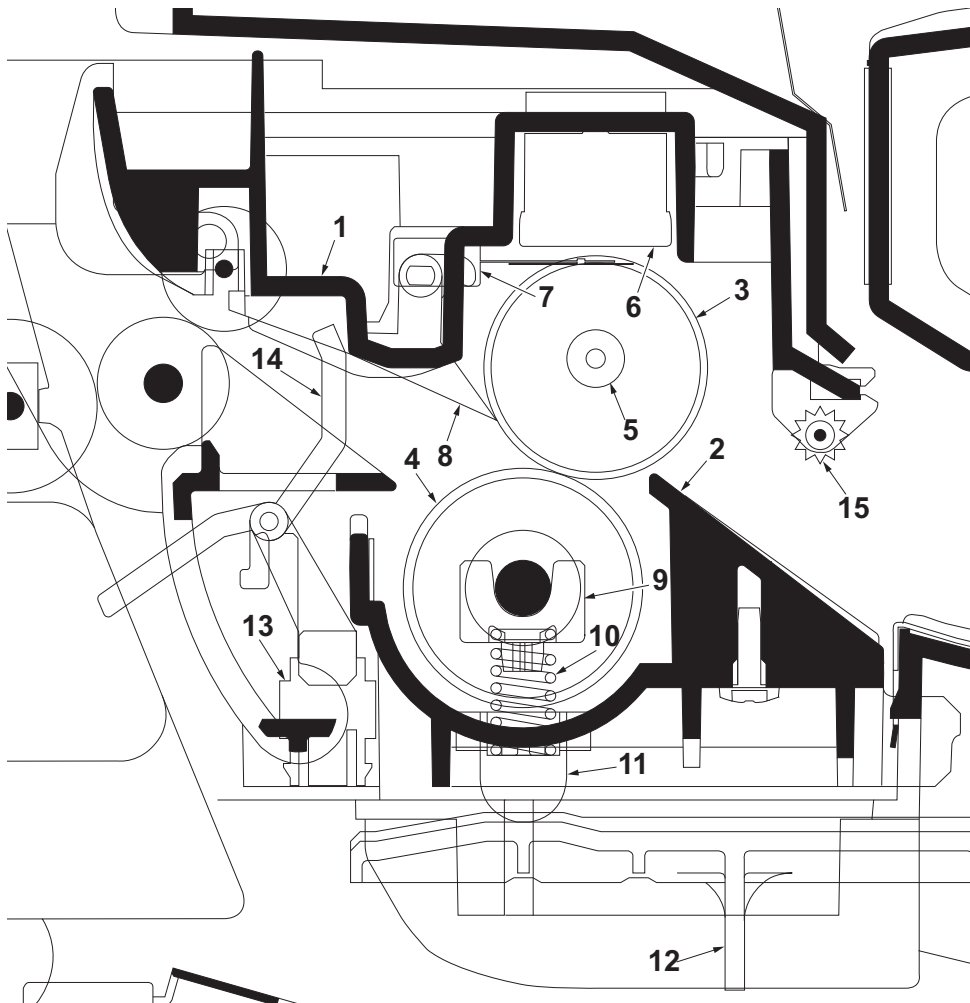

Figure 2-1-21 Fuser unit

- 1. Upper fuser frame
- 2. Lower fuser frame
- 3. Heat roller
- 4. Press roller
- 5. Fuser heater
- 6. Fuser thermostat
- 7. Fuser thermistor
- 8. Separators
- 9. Fuser bushes
- 10. Press springs
- 11. Press spring holders
- 12. Fuser lever L (R)
- 13. Exit sensor
- 14. Actuator (exit sensor)
- 15. Fuser guide pulley

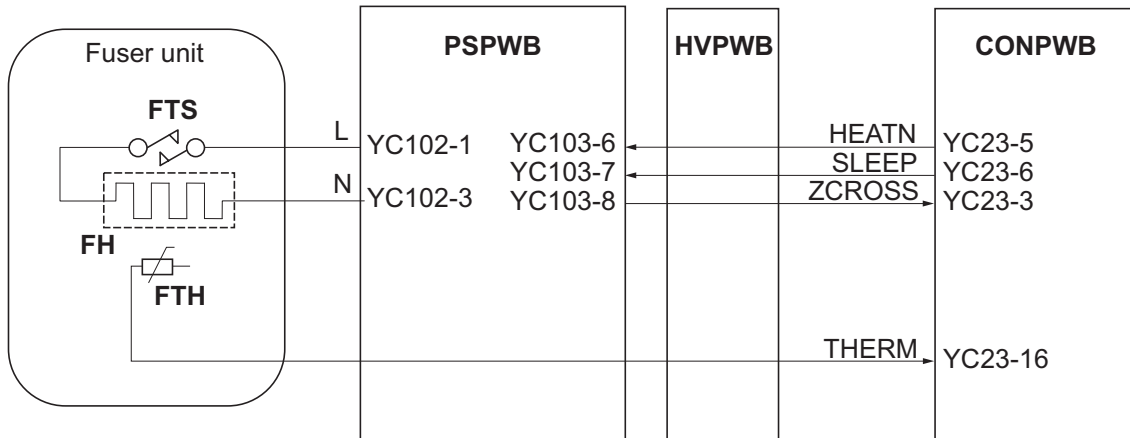

Figure 2-1-22 Fuser unit block diagram

2-1-8 Paper exit section

The paper exit section transports the paper which passed the fuser unit towards the top tray. The paper which passed through the fuser unit turns on the actuator (exit sensor) in the fuser unit, and is led by the guide comprised of the rear cover, frame and the FD cover guide, finally reaching the upper FD roller. The paper is delivered to the top tray by the rotation of the upper FD roller.

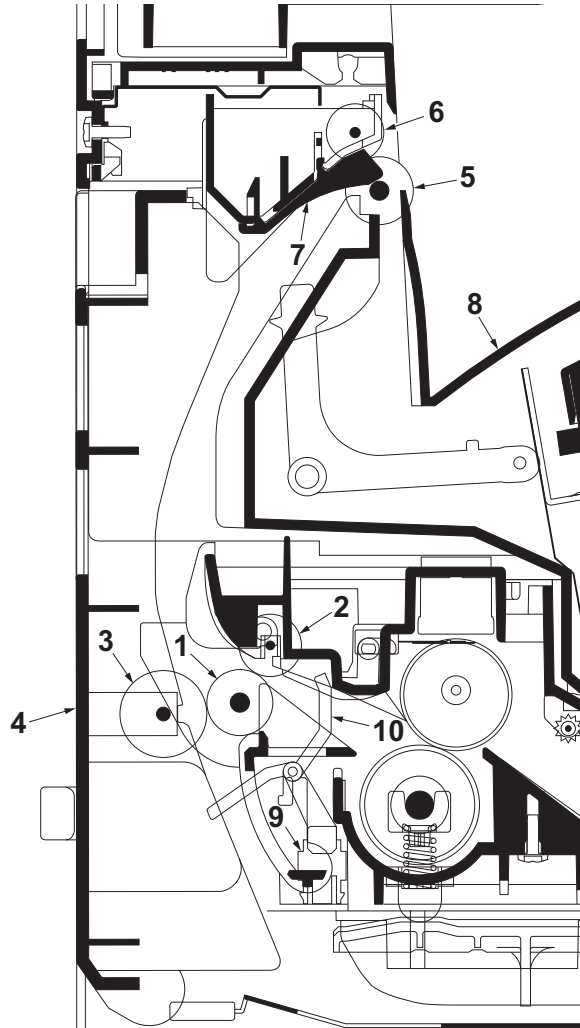

Figure 2-1-23 Paper exit section

1. Exit roller
2. Fuser exit pulley
3. Middle pulley
4. Rear cover
5. Upper FD roller
6. Exit pulley
7. FD cover
8. Top tray
9. Exit sensor
10. Actuator (exit sensor)

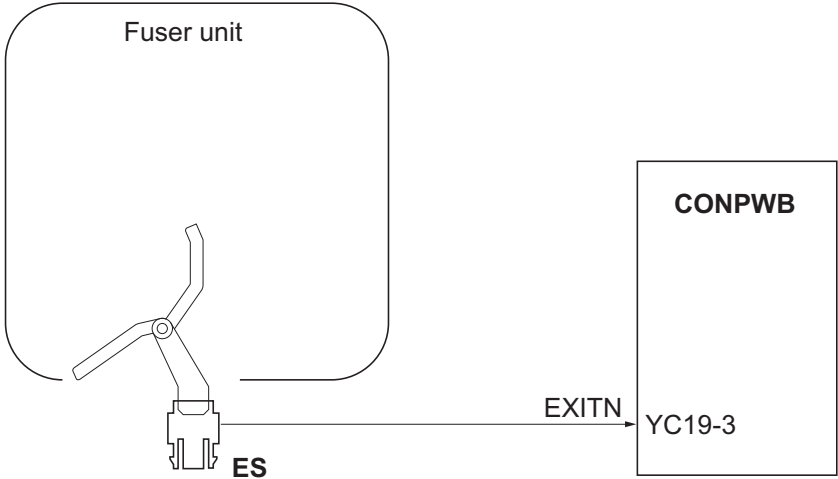

Figure 2-1-24 Paper exit section block diagram

2-1-9 Duplex/conveying section

The duplex/conveying section consists of conveying path which sends the paper sent from the exit section to the paper feed/conveying section when duplex printing.

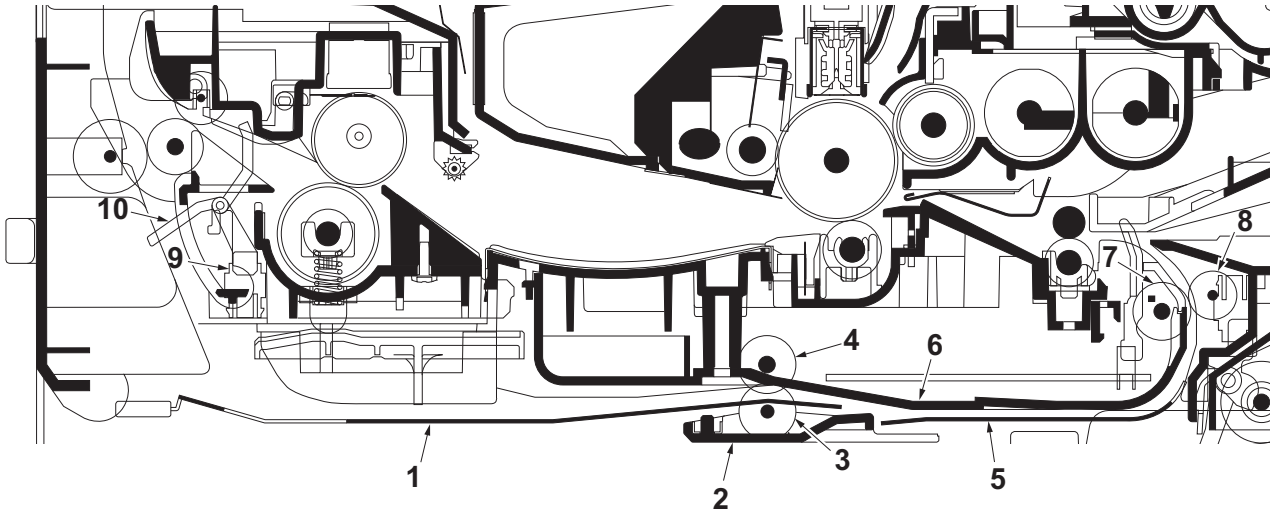

Figure 2-1-25 Duplex/conveying section

- | | |
|--------------------|----------------------------|
| 1. DU cover B | 6. Lower base cover |
| 2. DU holder | 7. Feed roller |
| 3. Middle pulley B | 8. Feed pulley |
| 4. DU roller | 9. Exit sensor |
| 5. DU cover A | 10. Actuator (exit sensor) |

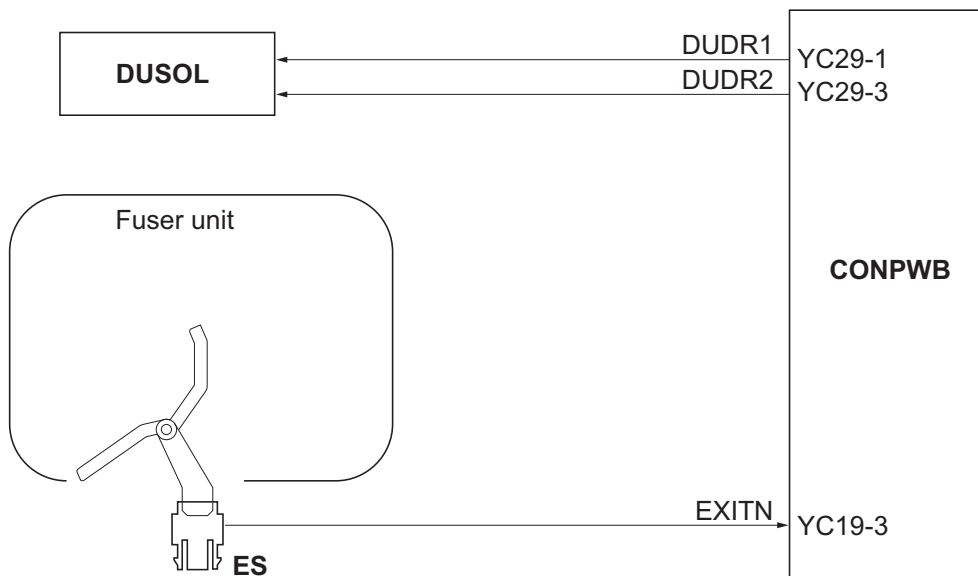

Figure 2-1-26 Duplex/paper conveying section block diagram

2-1-10 Document processor

(1) Original feed section

The original feed section consists of the parts shown in figure. An original placed on the original table is conveyed to the original conveying section. Original is fed by the rotation of the DP forwarding pulley and DP feed pulley.

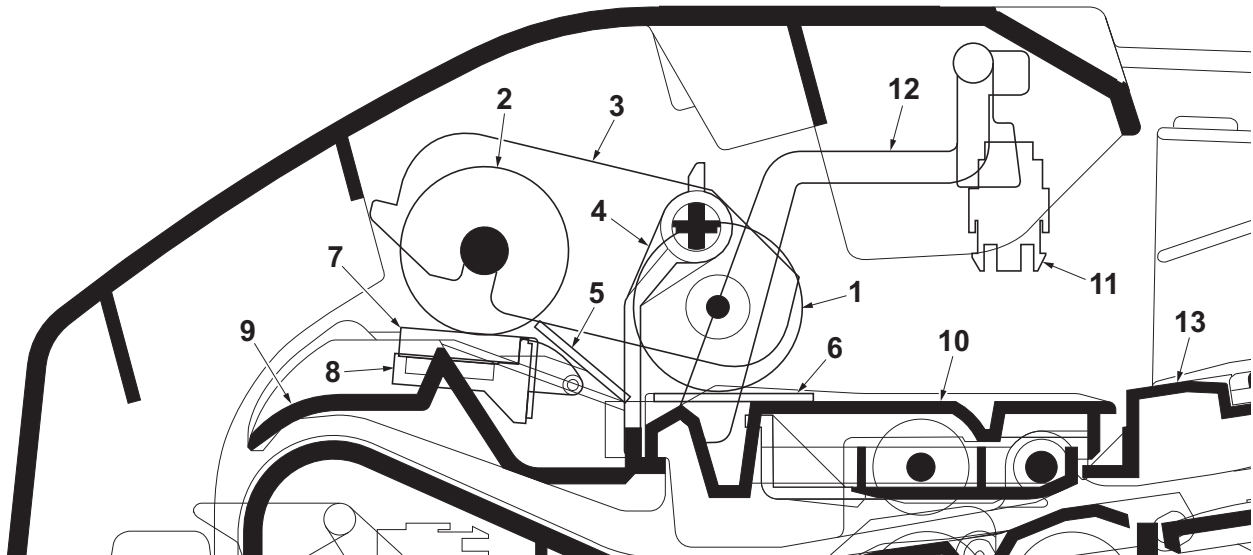

Figure 2-1-27 Original feed section

- | | |
|-------------------------|-----------------------------------|
| 1. DP forwarding pulley | 8. Separation mount |
| 2. DP feed pulley | 9. Upper guide |
| 3. LF holder | 10. Switchback guide |
| 4. PF stopper | 11. DP original sensor (DPOS) |
| 5. Front separation pad | 12. Actuator (DP original sensor) |
| 6. LF friction plate | 13. Original table |
| 7. DP separation pad | |

]

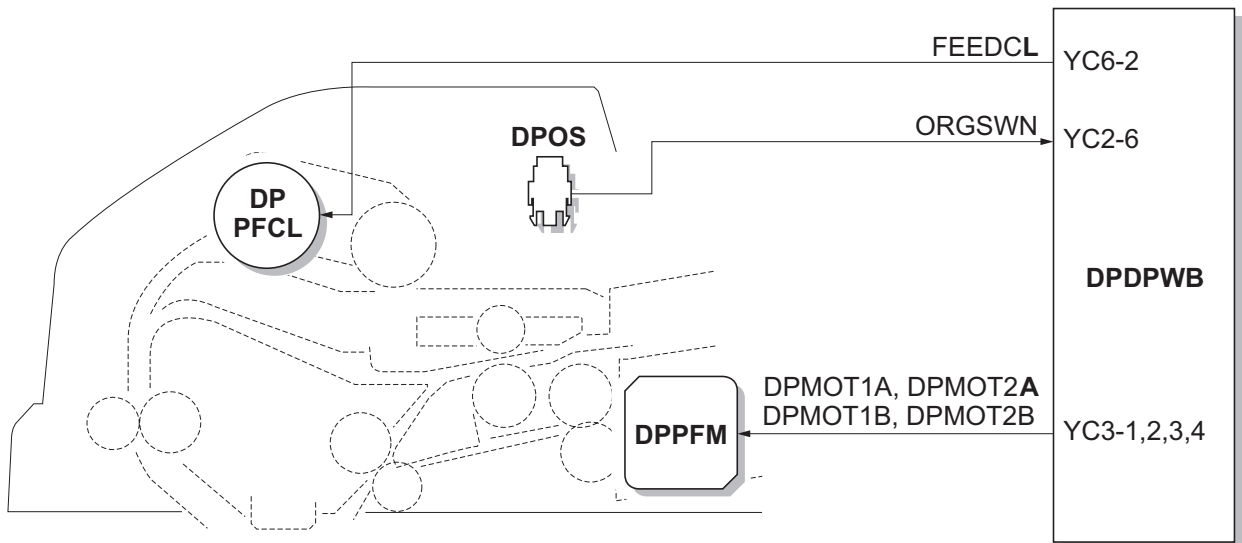

Figure 2-1-28 Original feed section block diagram

(2) Original conveying section

The original conveying section consists of the parts shown in figure. A conveyed original is scanned by the optical section (CCD) of main machine when it passes through the DP contact glass of main machine.

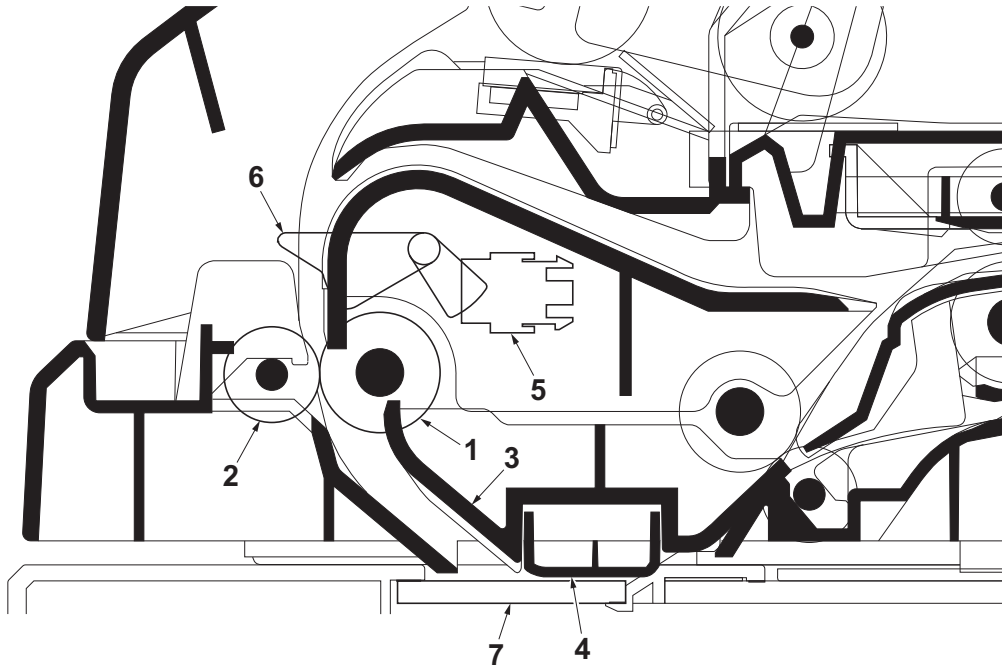

Figure 2-1-29 Original conveying section

- | | |
|-----------------------|--------------------------------|
| 1. Conveying roller A | 5. DP timing sensor (DPTS) |
| 2. Conveying pulley | 6. Actuator (DP timing sensor) |
| 3. Conveying bottom | 7. DP contact glass |
| 4. Reading guide | |

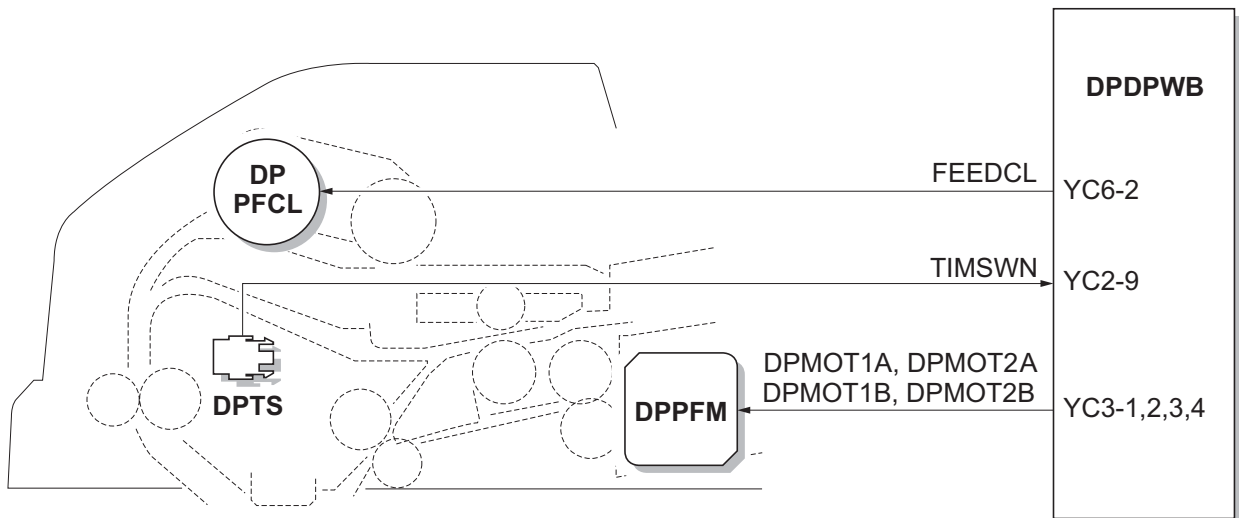

Figure 2-1-30 Original conveying section block diagram

(3) Original switchback/eject sections

The original switchback/eject sections consists of the parts shown in figure. An original of which scanning is complete is ejected to the original eject table by the eject roller. In the case of duplex switchback scanning, an original is conveyed temporarily to the switchback tray and conveyed again to the original conveying section by the switchback roller.

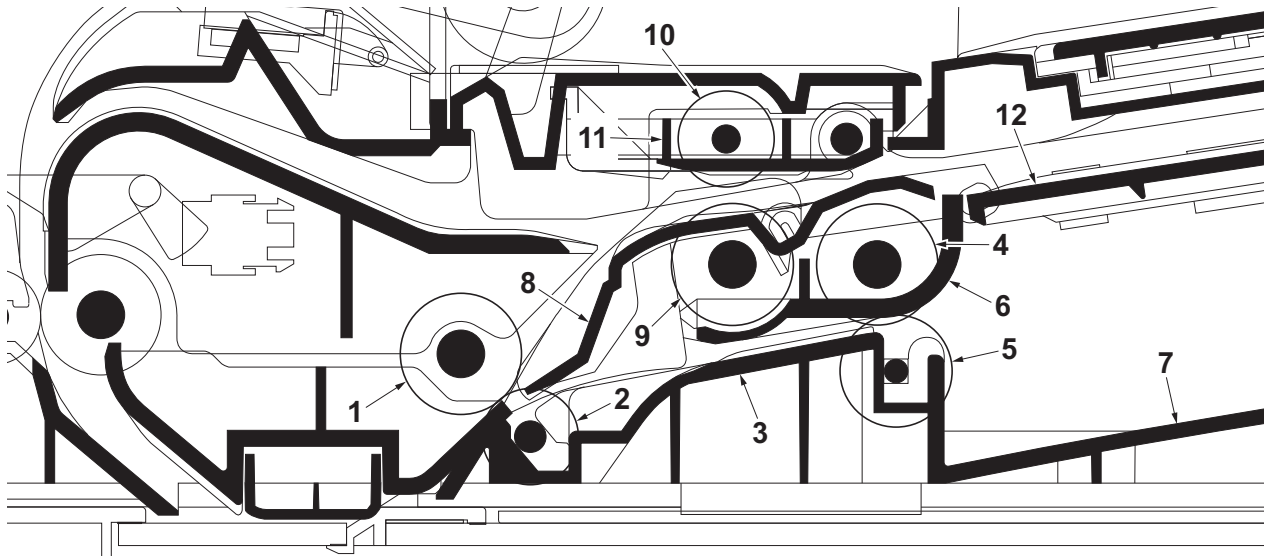

Figure 2-1-31 Original switchback/eject sections

- | | |
|-----------------------|-----------------------------|
| 1. Conveying roller B | 7. Original eject table |
| 2. Conveying pulley | 8. Switchback guide |
| 3. DP base | 9. Switchback roller |
| 4. Eject roller | 10. Switchback pulley |
| 5. Eject pulley | 11. Switchback pulley mount |
| 6. PF housing | 12. Switchback tray |

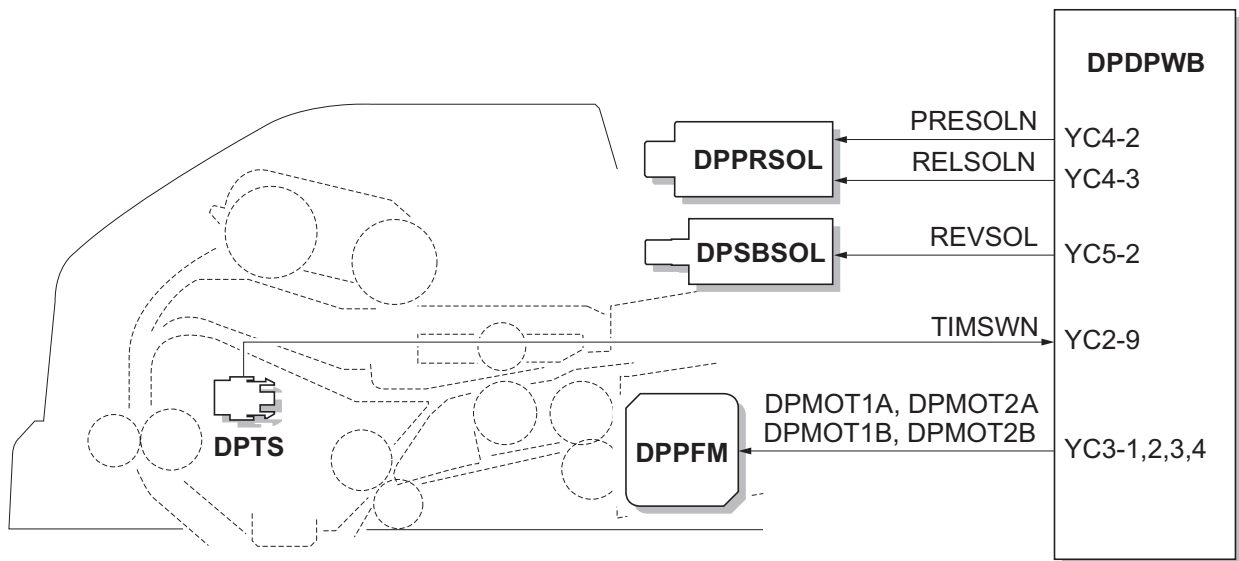

Figure 2-1-32 Original switchback/eject sections block diagram

This page is intentionally left blank.

2-2-1 Electrical parts layout

(1) PWBs

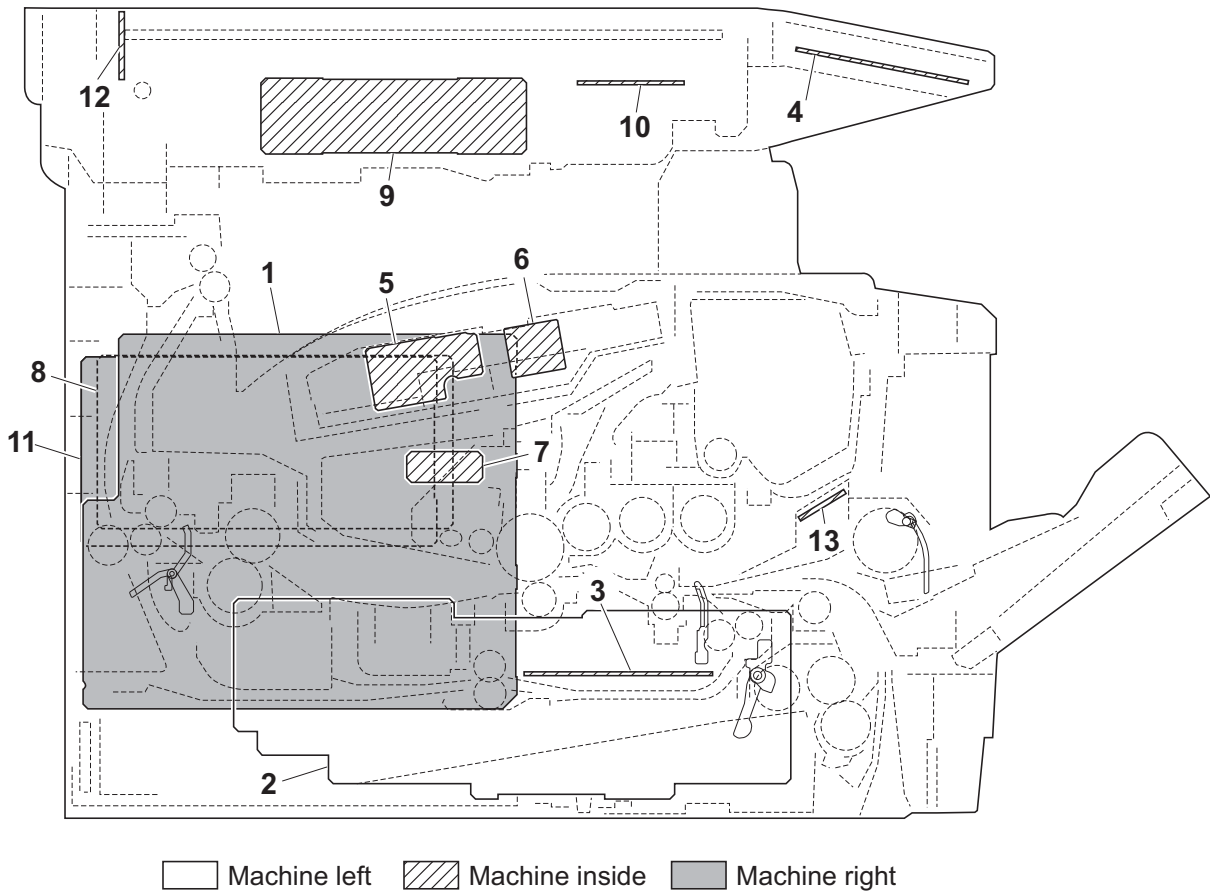

Figure 2-2-1 PWBs

- | | |
|--------------------------------------|--|
| 1. Control PWB (CONPWB)..... | Main controller: Controls the software such as the print data processing and provides the interface with computers.
Engine: Controls machine hardware such as high voltage/bias output control, paper conveying system control, and fuser temperature control, etc. |
| 2. Power source PWB (PSPWB) | After full-wave rectification of AC power source input, switching for converting to 24 V DC for output. Controls the Fuser heater. |
| 3. High voltage PWB (HVPWB) | Generates main charging, developing bias and transfer bias. |
| 4. Operation panel PWB (OPPWB) | Consists the LCD, LED indicators and key switches. |
| 5. APC PWB (APCPWB) | Generates and controls the laser beam. |
| 6. PD PWB (PDPWB) | Controls horizontal synchronizing timing of laser beam. |
| 7. Zener PWB (ZEPWB) | Adjusts the drum surface potential. |
| 8. Scanner PWB (SCPWB)..... | Controls the scanner section. |
| 9. CCD PWB (CCDPWB)..... | Reads the image of originals. |
| 10. LED drive PWB (LEDDRPWB) | Controls the exposure lamp. |
| 11. FAX control PWB (FCPWB)..... | Modulates, demodulates, compresses, decompresses and smoothes out image data, and converts resolution of image data. |
| 12. LED PWB (LEDPWB) | Exposes originals. |
| 13. RFID PWB (RFPWB)..... | Reads the container information. |

List of correspondences of PWB names

No.	Name used in service manual	Name used in parts list
1	Control PWB	PARTS MAIN PWB ASSY FS SP
1	Control PWB	PARTS MAIN PWB ASSY FS SP EU
2	Power source PWB	PARTS SWITCHING REGULATOR 120V SP
2	Power source PWB	PARTS SWITCHING REGULATOR 230V SP
3	High voltage PWB	HIGH VOLTAGE UNIT
4	Operation panel PWB	PARTS PANEL PWB ASSY SP
5	APC PWB	-
6	PD PWB	-
7	Zener PWB	-
8	Scanner PWB	PARTS SCANNER PWB ASSY SP
9	CCD PWB	-
10	LED drive PWB	-
11	FAX control PWB	PARTS MAIN FAX ASSY U SP
11	FAX control PWB	PARTS MAIN FAX ASSY E SP
12	LED PWB	-
13	RFID PWB (RFPWB)	PARTS PWB RFID ASSY SP

(2) Switches and sensors

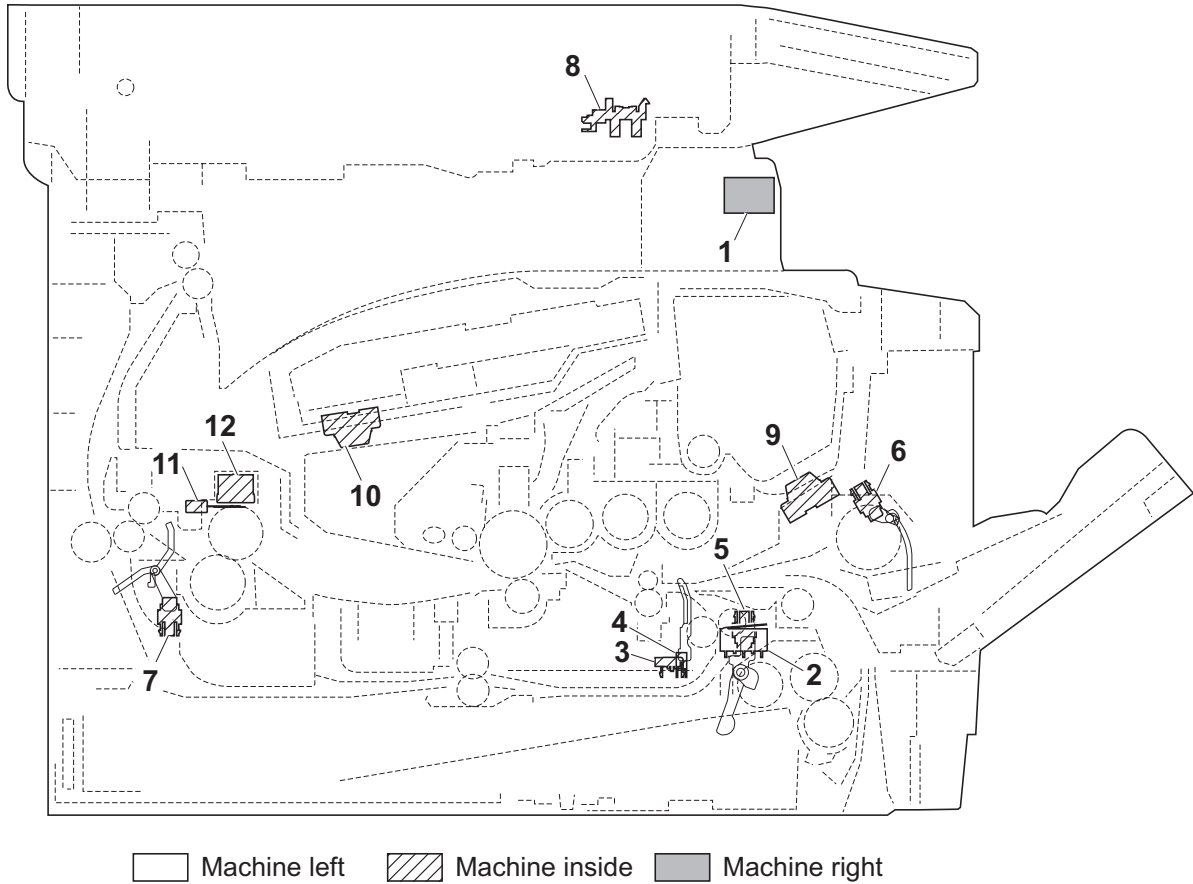

Figure 2-2-2 Switches and sensors

- | | |
|-------------------------------------|---|
| 1. Power switch (MSW)..... | Switches of main body operation. |
| 2. Interlock switch (ILSW) | Shuts off 24 V DC power line when the front cover is opened. |
| 3. Cassette switch (COCSW)..... | Detects open/close cassette. |
| 4. Registration sensor (RS)..... | Detects the timing of primary paper feed. |
| 5. Paper sensor (PS) | Detects the presence of paper in the cassette. |
| 6. MP paper sensor (MPPS) | Detects the presence of paper on the MP tray. |
| 7. Exit sensor (ES) | Detects paper jam in the fuser or duplex conveying section. |
| 8. Home position sensor (HPS) | Detects the ISU in the home position. |
| 9. Toner sensor (TS) | Detects the quantity of toner in a toner container. |
| 10. Waste toner sensor (WTS)..... | Detects when the waste toner reservoir (Drum unit) is full. |
| 11. Fuser thermistor (FTH) | Measures the heat roller temperature. |
| 12. Fuser thermostat (FTS)..... | Shuts off the power source to the Fuser heater when the heat roller reaches extremely high temperature. |

(3) Other electrical components

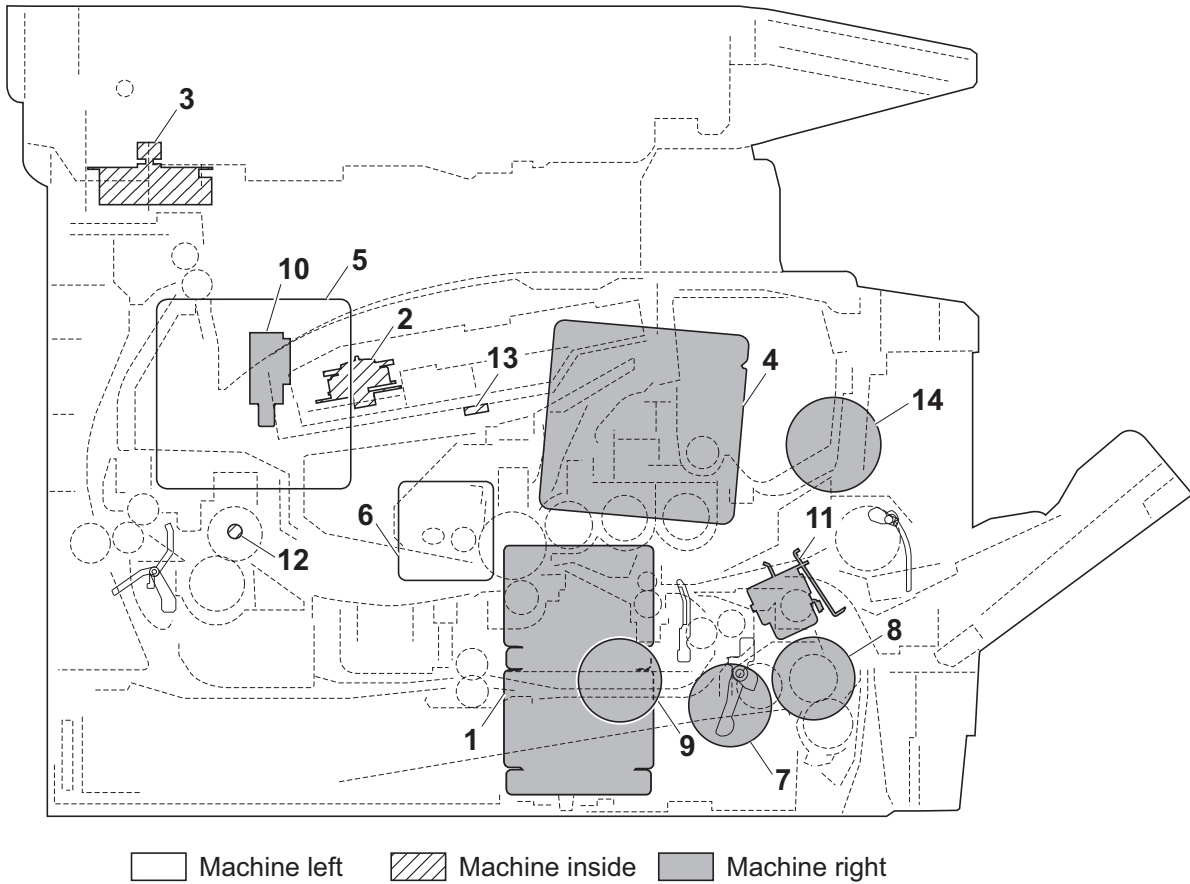

Figure 2-2-3 Other electrical components

- 1. Main motor (MM)..... Drives the paper feed/conveying section and fuser unit.
- 2. Polygon motor (PM)..... Drives the polygon mirror.
- 3. ISU motor (ISUM) Drives the ISU.
- 4. Right cooling fan motor (RFM)..... Cools the interior of machine.
- 5. Left cooling fan motor (LFM)..... Cools the interior of machine.
- 6. Power source fan motor (PSFM) Cools the interior of machine.
- 7. Registration clutch (RCL)..... Controls the secondary paper feed.
- 8. Paper feed clutch (PFCL) Controls the paper cassette paper feed.
- 9. Developing clutch (DEVCL) Controls the toner feed.
- 10. Duplex solenoid (DUCL) Controls the paper conveying at the duplex conveying section.
- 11. MP paper feed solenoid (MPPFSOL) ... Controls the MPF bottom plate of the MP tray.
- 12. Fuser heater (FH) Heats the heat roller.
- 13. Cleaning lamp (CL)..... Eliminates the residual electrostatic charge on the drum.
- 14. Speaker (SP)..... Outputs buzzer, monitoring and speaker sounds.

(4) Document processor

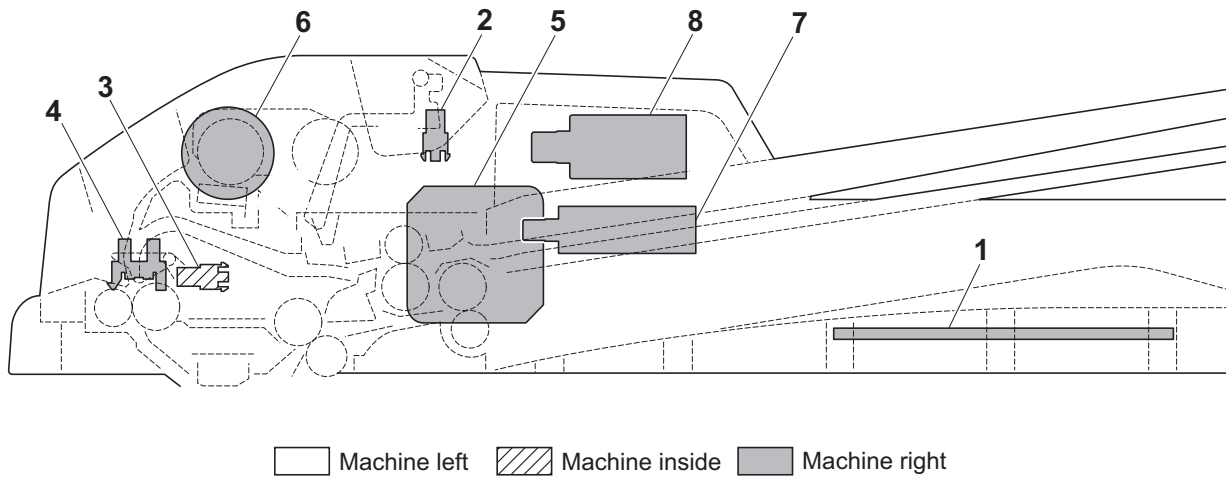

Figure 2-2-4 Document processor

- 1. DP drive PWB (DPDPWB)..... Consists the solenoids and clutch driver circuit and wiring relay circuit.
- 2. DP original sensor (DPOS) Detects the presence of an original.
- 3. DP timing sensor (DPTS)..... Detects the original scanning timing.
- 4. DP open/close sensor (DPOCS)..... Detects the opening/closing of the DP.
- 5. DP paper feed motor (DPPFM)..... Drives the original feed section.
- 6. DP paper feed clutch (DPPFCL)..... Controls the drive of the forwarding pulley and feed pulley.
- 7. DP switchback solenoid (DPSBSOL).... Operates the switchback guide.
- 8. DP pressure solenoid (DPPRSOL) Operates the switchback pulley.

List of correspondences of PWB names

No.	Name used in service manual	Name used in parts list
1	DP drive PWB	PARTS DRIVER PWB ASSY SP

This page is intentionally left blank.

2-3-1 Power source PWB

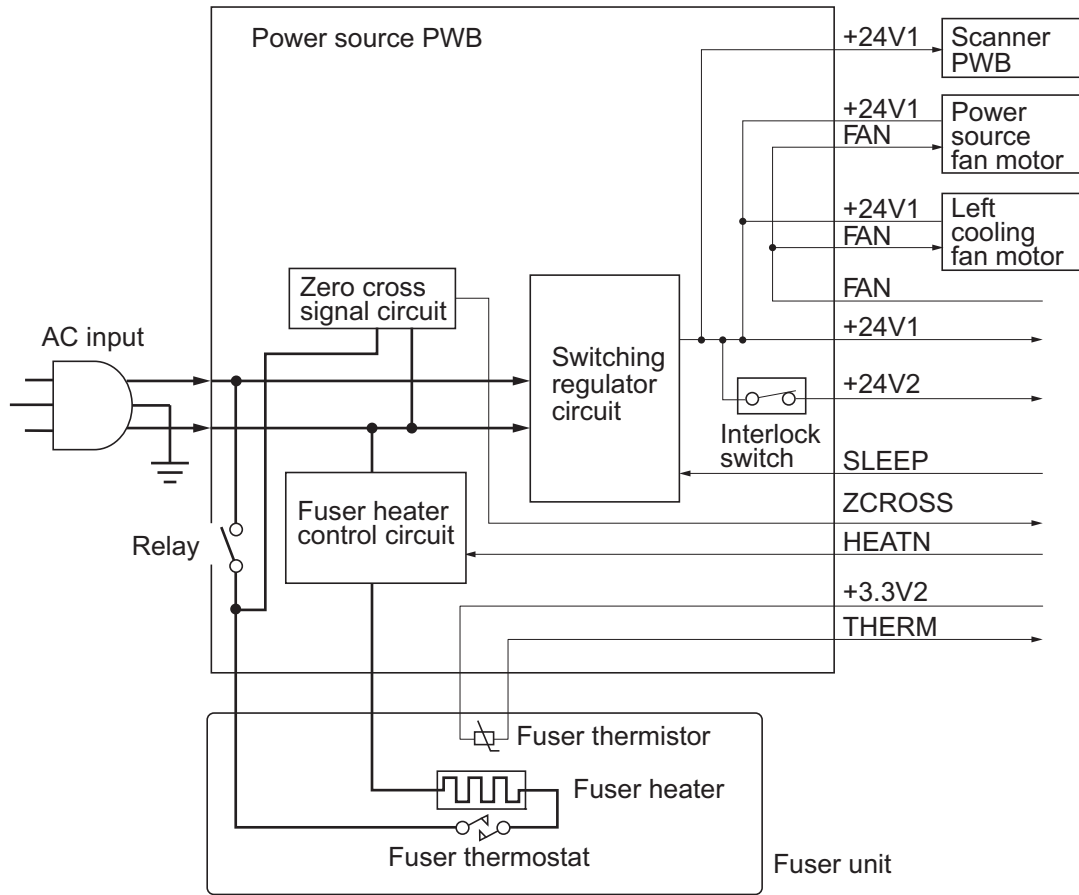

Figure 2-3-1 Power source PWB block diagram

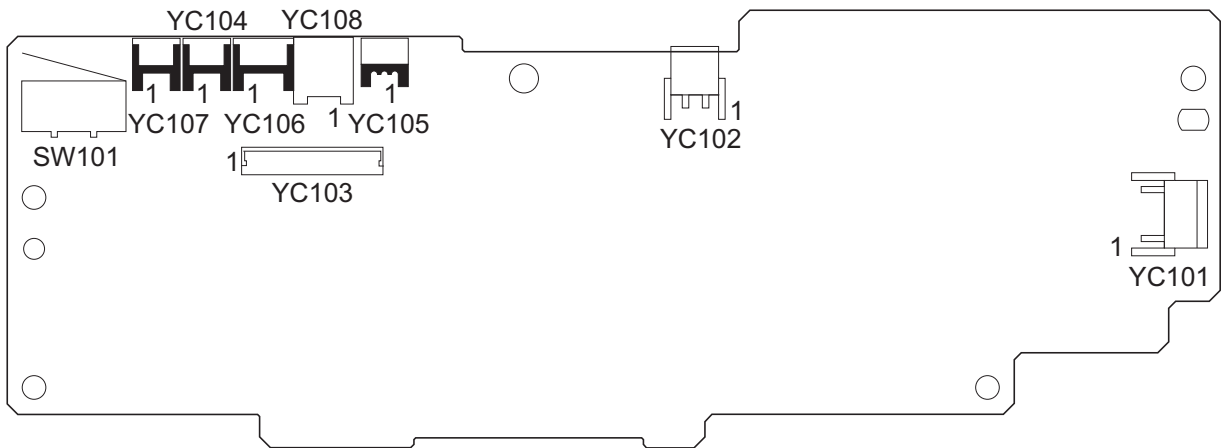

Figure 2-3-2 Power source PWB silk-screen diagram

Connector	Pin	Signal	I/O	Voltage	Description
YC101 Connected to the AC inlet	1	NEUTRAL	I	120 V AC 220 - 240 V AC	AC power input
	2	LIVE	I	120 V AC 220 - 240 V AC	AC power input
YC102 Connected to the Fuser heater	1	LIVE	O	120 V AC 220 - 240 V AC	Fuser heater output
	2	NEUTRAL	O	120 V AC 220 - 240 V AC	Fuser heater output
YC103 Connected to the high voltage PWB	1	+24V1	O	24 V DC	24 V DC power source
	2	SGND	-	-	Ground
	3	FAN	I	0/24 V DC	Left cooling fan motor: On/Off
	4	THERM	O	Analog	Fuser thermistor detection voltage
	5	+3.3V1	I	3.3 V DC	3.3 V DC power source
	6	HEATN	I	0/3.3 V DC	Fuser heater: On/Off
	7	SLEEP	I	0/3.3 V DC	Sleep mode signal: On/Off
	8	ZCROSS	O	0/3.3 V DC (pulse)	Zero cross signal
	9	+24V2	O	24 V DC	24 V DC power source (via interlock switch)
	10	+24V2	O	24 V DC	24 V DC power source (via interlock switch)
	11	PGND	-	-	Ground
	12	PGND	-	-	Ground
YC104 Connected to the left cooling fan motor	1	+24V1	O	24 V DC	24 V DC power source
	2	FAN	O	0/24 V DC	Left cooling fan motor: On/Off
YC105 Connected to the fuser thermistor	1	+3.3V1	O	3.3 V DC	3.3 V DC power source
	2	N.C.	-	-	Not used
	3	THERM	I	Analog	Fuser thermistor detection voltage
YC106 Connected to the scanner PWB	1	+24V1	O	24 V DC	24 V DC power source
	2	N.C.	-	-	Not used
	3	GND	-	-	Ground

Connector	Pin	Signal	I/O	Voltage	Description
YC107	1	+24V1	O	24 V DC	24 V DC power source
Connected to the power source fan motor	2	FAN	O	0/24 V DC	Power source fan motor: On/Off
YC108	1	-	-	-	Frame ground (Control PWB)
Connected to the ground terminals	2	-	-	-	Frame ground (Frame)
	3	-	-	-	Frame ground (Frame)

2-3-2 Control PWB

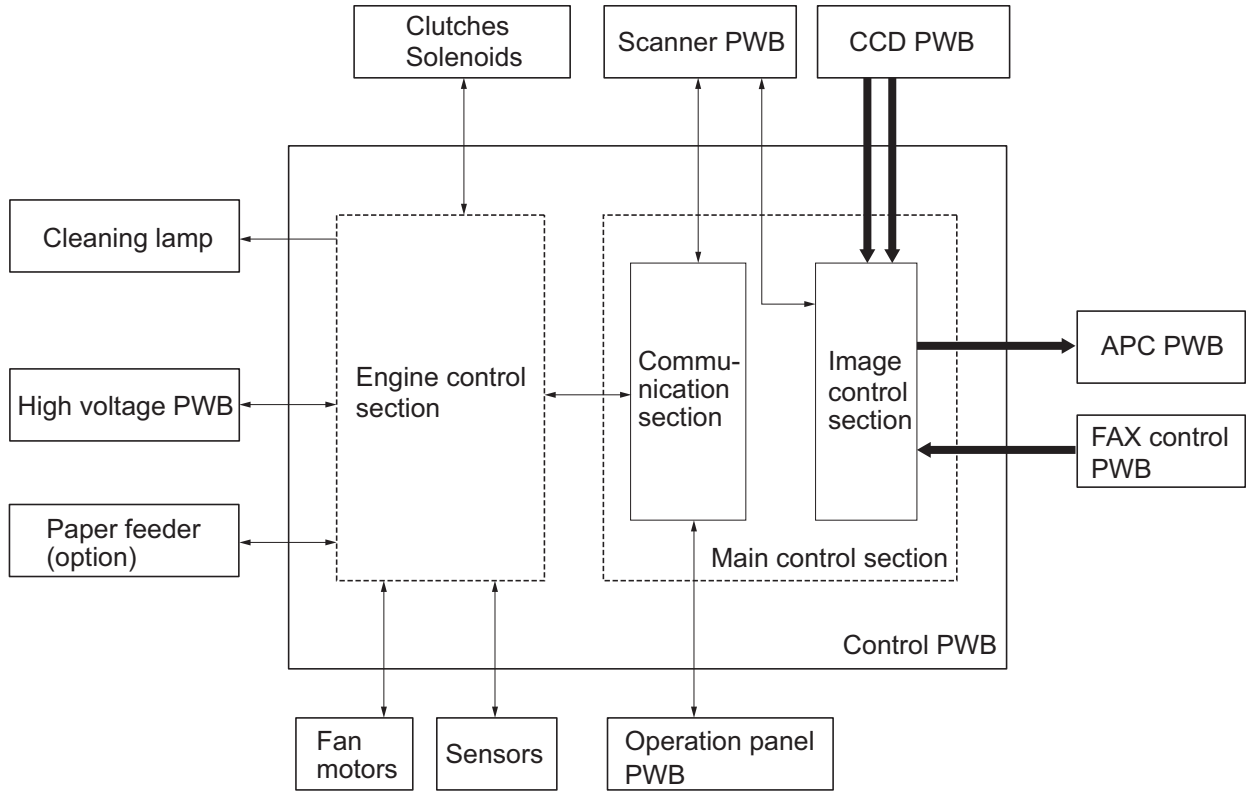

Figure 2-3-3 Control PWB block diagram

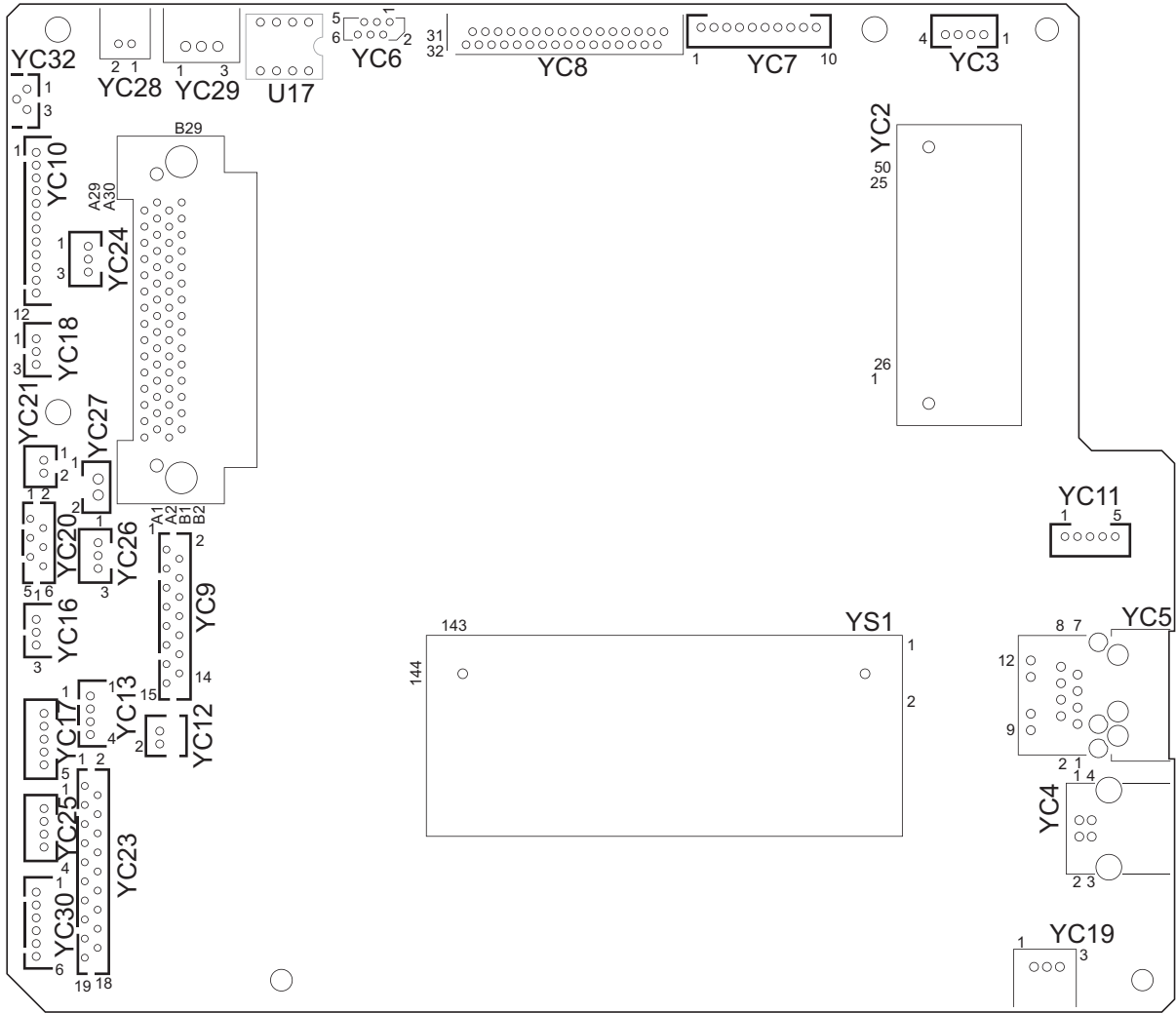

Figure 2-3-4 Control PWB silk-screen diagram

Connector	Pin	Signal	I/O	Voltage	Description
YC6 Connected to the scanner PWB	1	+12V	O	12 V DC	12 V DC power source
	2	GND	-	-	Ground
	3	HPSW	O	0/3.3 V DC	Home position sensor: On/Off
	4	GND	-	-	Ground
	5	NC	-	-	Not used
	6	LAMP	I	0/24 V DC	Exposure lamp drive signal
YC7 Connected to the operation panel PWB	1	GND	-	-	Ground
	2	PANCTS	I	0/3.3 V DC (pulse)	Transmitting enable signal
	3	PANRTS	O	0/3.3 V DC (pulse)	Receiving enable signal
	4	+3.3V1	O	0/3.3 V DC	Home position sensor: On/Off
	5	PANRXD	I	0/3.3 V DC (pulse)	Operation panel PWB receiving data
	6	PANTXD	O	0/3.3 V DC (pulse)	Operation panel PWB transmitting data
	7	FPRSTN	O	3.3/0 V DC	Operation panel PWB reset signal
	8	GND	-	-	Ground
	9	POWERKEY	I	3.3/0 V DC	Power key input signal
	10	+5V1	O	5 V DC	5 V DC power source
YC8 Connected to the CCD PWB	1	LAMP	O	0/24 V DC	Exposure lamp drive signal
	2	NC	-	-	Not used
	3	GND	-	-	Ground
	4	GND	-	-	Ground
	5	HPSW	I	0/3.3 V DC	Home position sensor: On/Off
	6	+3.3V1	O	3.3 V DC	3.3 V DC power source
	7	NC	-	-	Not used
	8	CCDRSN	O	LVDS	CCD reset signal (-)
	9	CCDRSP	O	LVDS	CCD reset signal (+)
	10	NC	-	-	Not used
	11	CCDCLPP	O	LVDS	CCD reset signal (-)
	12	CCDCLPN	O	LVDS	CCD reset signal (+)
	13	NC	-	-	Not used
	14	CCDPH1N	O	LVDS	CCD shift register clock signal (-)
	15	CCDPH1P	O	LVDS	CCD shift register clock signal (+)
	16	NC	-	-	Not used
	17	CCDPH2P	O	LVDS	CCD shift register clock signal (-)
	18	CCDPH2N	O	LVDS	CCD shift register clock signal (+)
	19	NC	-	-	Not used
	20	CCDSH	O	LVDS	CCD shift gate signal (-)

Connector	Pin	Signal	I/O	Voltage	Description
YC8	21	CCDSW	O	LVDS	CCD color/BW change signal (+)
Connected to the CCD PWB	22	GND	-	-	Ground
	23	CCDDATAR	I	LVDS	CCD image output signal (Red)
	24	GND	-	-	Ground
	25	CCDDATAG	I	LVDS	CCD image output signal (Green)
	26	GND	-	-	Ground
	27	CCDDATAB	I	LVDS	CCD image output signal (Blue)
	28	GND	-	-	Ground
	29	+12V	O	12 V DC	12 V DC power source (For exposure lamp)
	30	GND	-	-	Ground
	31	+5V1	O	5 V DC	5 V DC power source
	32	+5V1	O	5 V DC	5 V DC power source
	YC9	1	GND	-	-
Connected to the scanner PWB	2	+3.3V1	O	3.3 V DC	3.3 V DC power source
	3	CPUCLK	I	0/3.3 V DC (pulse)	Serial communications clock signal
	4	CPUSI	I	0/3.3 V DC (pulse)	Serial communications data input
	5	CPUSO	O	0/3.3 V DC (pulse)	Serial communications data output
	6	CPUSEL	I	0/3.3 V DC	Communications select signal
	7	CPURDY	O	0/3.3 V DC	Communications ready signal
	8	OVMONOUT	O	0/3.3 V DC	Communications ready signal
	9	PAGESET	O	0/3.3 V DC	Vertical synchronizing monitor signal
	10	SEGSO	I	0/3.3 V DC	Vertical synchronizing signal
	11	SSCKN	O	0/3.3 V DC (pulse)	Serial communications clock
	12	SEGSi	O	0/3.3 V DC (pulse)	Serial communications data input
	13	SSBSY	I	0/3.3 V DC	Impossible transmission/Completion notice signal
	14	SSDIR	I	0/3.3 V DC	Serial communications T/R switching signal
	15	SEGIR	I	0/3.3 V DC	Serial communications interruption demand signal

Connector	Pin	Signal	I/O	Voltage	Description
YC10	1	+24V3	O	24 V DC	24 V DC power source
Connected to the laser scanner unit	2	GND	-	-	Ground
	3	PLGDRN	O	0/3.3 V DC	Polygon motor: On/Off
	4	PLGRDY	I	0/3.3 V DC	Polygon motor ready signal
	5	PLGCLK	O	0/3.3 V DC (pulse)	Polygon motor clock signal
	6	PDN	I	0/3.3 V DC (pulse)	Horizontal synchronizing signal
	7	GND	-	-	Ground
	8	VDON	O	0/3.3 V DC (pulse)	Video data signal (+)
	9	VDOP	O	0/3.3 V DC (pulse)	Video data signal (-)
	10	OUTPEN	O	0/3.3 V DC	Laser output enable signal
	11	SAMPLEN	O	0/3.3 V DC	Sample/hold timing switching signal
	12	+3.3V1	O	3.3 V DC	3.3 V DC power source
YC12	1	OUT-	O	Analog	Speaker sound signal (-)
Connected to the speaker	2	OUT+	O	Analog	Speaker sound signal (+)
YC16	1	PILED	O	3.3 V DC	3.3 V DC power source
Connected to the MP paper sensor	2	GND	-	-	Ground
	3	HANDSN	I	0/3.3 V DC	MP paper sensor: On/Off
YC17	1	+24V3	O	24 V DC	24 V DC power source
Connected to the main motor	2	GND	-	-	Ground
	3	MMOTRDYN	I	0/3.3 V DC	Main motor ready signal
	4	MMOTCLK	O	0/3.3 V DC (pulse)	Main motor clock signal
	5	REMOTEN	O	0/3.3 V DC	Main motor: On/Off
YC18	1	PILED	O	3.3 V DC	3.3 V DC power source
Connected to the paper sensor	2	GND	-	-	Ground
	3	PAPER	I	0/3.3 V DC	Paper sensor: On/Off
YC19	1	PILED	O	3.3 V DC	3.3 V DC power source
Connected to the exit sensor	2	GND	-	-	Ground
	3	EXITN	I	0/3.3 V DC	Exit sensor: On/Off

Connector	Pin	Signal	I/O	Voltage	Description
YC20 Connected to the registration clutch, paper feed clutch and developing clutch	1	+24V3	O	24 V DC	24 V DC power source
	2	REGDRN	O	0/24 V DC	Registration clutch: On/Off
	3	+24V3	O	24 V DC	24 V DC power source
	4	FEDDRN	O	0/24 V DC	Paper feed clutch: On/Off
	5	+24V3	O	24 V DC	24 V DC power source
	6	DLPDRN	O	0/24 V DC	Developing clutch: On/Off
YC21 Connected to the MP paper feed solenoid	1	+24V3	O	24 V DC	24 V DC power source
	2	MPFDRN	O	0/24 V DC	MP paper feed solenoid: On/Off
YC23 Connected to the high voltage PWB	1	+24V1	I	24 V DC	24 V DC power source
	2	+3.3V1	O	3.3 V DC	3.3 V DC power source
	3	ZCROSS	I	0/3.3 V DC (pulse)	Zero cross signal
	4	FAN	O	0/24 V DC	Left cooling fan motor: On/Off
	5	HEATN	O	0/3.3 V DC	Fuser heater: On/Off
	6	SLEEP	O	0/3.3 V DC	Sleep mode signal: On/Off
	7	MHVDR	O	0/3.3 V DC	Main charger output signal: On/Off
	8	RTHVDR	O	0/3.3 V DC	Transfer (reverse) bias output signal: On/Off
	9	PSEL1	O	0/3.3 V DC	Transfer (reverse) bias control signal: On/Off
	10	HVCLK	O	0/3.3 V DC (pulse)	Developing bias clock signal
	11	REGN	I	0/3.3 V DC	Registration sensor: On/Off
	12	TCNT	O	PWM	Transfer current control signal
	13	MCNT	O	PWM	Main charger output control signal
	14	THVDR	O	0/3.3 V DC	Transfer bias output signal: On/Off
	15	CASE	I	Analog	Cassette switch: On/Off
	16	THERM	I	Analog	Fuser thermistor detection voltage
	17	+24V3	O	24 V DC	24 V DC power source
	18	SGND	-	-	Ground
	19	SEPA	-	-	-
YC24 Connected to the waste toner sensor	1	+3.3V1	O	3.3 V DC	3.3 V DC power source
	2	TNFULL	I	0/3.3 V DC	Waste toner full detection signal
	3	SGND	-	-	Ground

Connector	Pin	Signal	I/O	Voltage	Description
YC25 Connected to the high voltage PWB	1	+24V2	I	24 V DC	24 V DC power source
	2	+24V2	I	24 V DC	24 V DC power source
	3	PGND	-	-	Ground
	4	PGND	-	-	Ground
YC26 Connected to the toner sensor	1	+3.3V1	O	3.3 V DC	3.3 V DC power source
	2	EMPTY	I	0/3.3 V DC	Toner quantity detection signal
	3	SGND	-	-	Ground
YC27 Connected to the right cooling fan motor	1	+24V1	O	24 V DC	24 V DC power source
	2	FAN	O	0/24 V DC	Right cooling fan motor: On/Off
YC28 Connected to the eraser lamp	1	ERASER	O	0/24 V DC	Eraser lamp: On/Off
	2	ERASRW	O	24 V DC	24 V DC power source
YC29 Connected to the duplex solenoid	1	DUDR1	O	0/24 V DC	Duplex solenoid (activate): On/Off
	2	COMMON	O	24 V DC	24 V DC power source
	3	DUDR2	O	0/24 V DC	Duplex solenoid (return): On/Off
YC30 Connected to the optional paper feeder (PF main PWB)	1	+24V3	O	24 V DC	24 V DC power source
	2	PGND	-	-	Ground
	3	PFSI	I	0/3.3 V DC (pulse)	Serial communication data input signal
	4	PFSO	O	0/3.3 V DC (pulse)	Serial communication data output signal
	5	PSEL	O	0/3.3 V DC	Paper feeder selection signal
	6	+3.3V1	O	3.3 V DC	3.3 V DC power source
YC32 Connected to the power switch	1	POWERSW	I	0/3.3 V DC	Power switch: On/Off
	2	NC	-	-	Not used
	3	GND	-	-	Ground

2-3-3 Scanner PWB

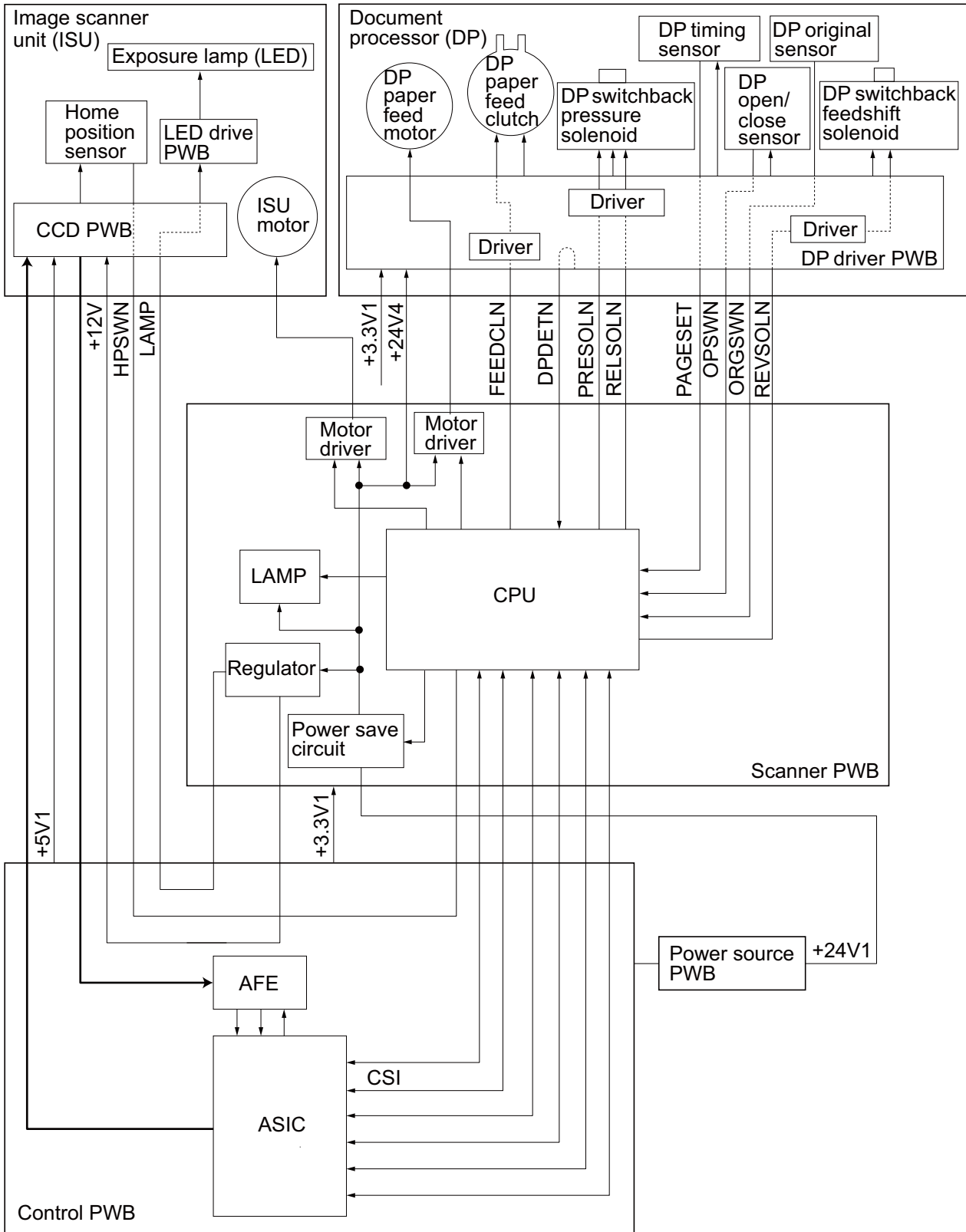

Figure 2-3-5 Scanner PWB block diagram

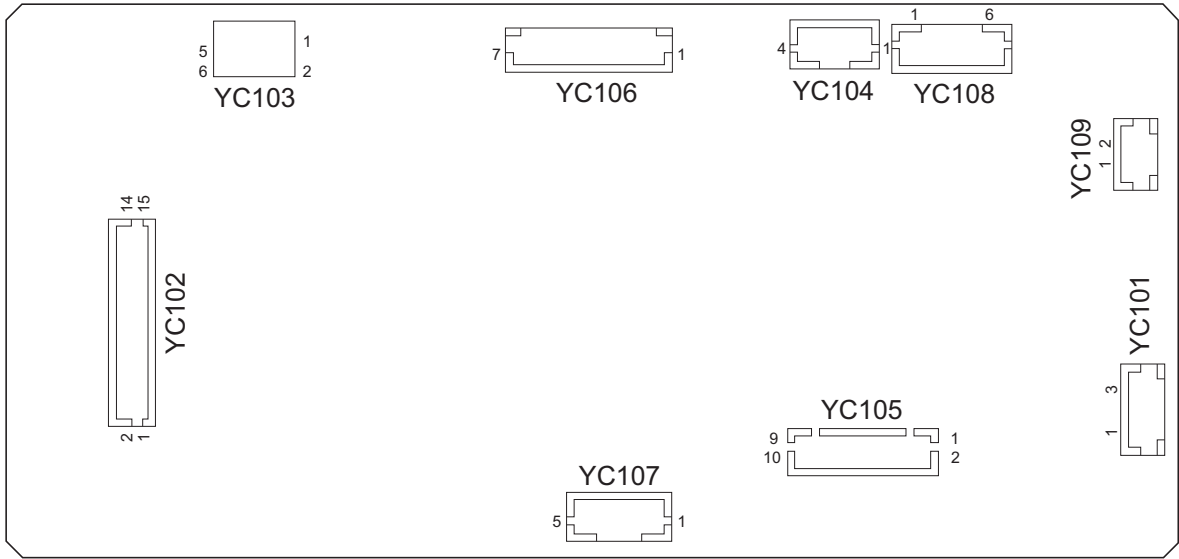

Figure 2-3-6 Scanner PWB silk-screen diagram

Connector	Pin	Signal	I/O	Voltage	Description
YC101 Connected to the power source PWB	1	+24V1	O	24 V DC	24 V DC power source
	2	N.C.	-	-	Not used
	3	GND	-	-	Ground
YC102 Connected to the control PWB	1	SEGIR	O	0/3.3 V DC	Serial communications interruption demand
	2	SSDIR	O	0/3.3 V DC	Serial communications trans./recep. change
	3	SSBSY	O	0/3.3 V DC	Impossible transmission/Completion notice
	4	SEGSi	I	0/3.3 V DC (pulse)	Serial communications data output
	5	SSCKN	I	0/3.3 V DC (pulse)	Serial communications clock
	6	SEGSO	O	0/3.3 V DC	Vertical synchronizing signal
	7	PAGESET	I	0/3.3 V DC	Vertical synchronizing monitor signal
	8	OVMONOUT	I	0/3.3 V DC	Communications ready signal
	9	CPURDY	I	0/3.3 V DC	Communications ready signal
	10	CPUSEL	O	0/3.3 V DC	Communications select signal
	11	CPUSO	I	0/3.3 V DC (pulse)	Serial communications data input
	12	CPUSI	O	0/3.3 V DC (pulse)	Serial communications data output
	13	CPUCLK	O	0/3.3 V DC (pulse)	Serial communications clock signal
	14	+3.3V1	I	3.3 V DC	3.3 V DC power source
	15	GND	-	-	Ground

Connector	Pin	Signal	I/O	Voltage	Description
YC103	1	+12V	I	12 V DC	12 V DC power source
Connected to the control PWB	2	GND	-	-	Ground
	3	HPSW	I	0/3.3 V DC	Home position sensor: On/Off
	4	GND	-	-	Ground
	5	NC	-	-	Not used
	6	LAMP	I	0/24 V DC	Exposure lamp drive signal
YC104	1	SCMOT1A	O	0/24 V DC (pulse)	ISU motor drive pulse
Connected to the ISU motor	2	SCMOT2A	O	0/24 V DC (pulse)	ISU motor drive pulse
	3	SCMOT1B	O	0/24 V DC (pulse)	ISU motor drive pulse
	4	SCMOT2B	O	0/24 V DC (pulse)	ISU motor drive pulse
YC105	1	+3.3V1	O	3.3 V DC	3.3 V DC power source
Connected to the DP driver PWB	2	GND	-	-	Ground
	3	TIMSWN	I	0/3.3 V DC	DP timing sensor: On/Off
	4	ORGSWN	I	0/3.3 V DC	DP original sensor: On/Off
	5	OPSWN	I	0/3.3 V DC	DP open/close sensor: On/Off
	6	DPDETN	I	0/3.3 V DC	DP installation detection signal
	7	RELSOLN	O	0/24 V DC	DP switchback pressure solenoid: (Release) On/Off
	8	PRESOLN	O	0/24 V DC	DP switchback pressure solenoid (Press.): On/Off
	9	REVSOL	O	0/24 V DC	DP switchback feedshift solenoid: On/Off
	10	FEEDCL	O	0/24 V DC	DP paper feed clutch: On/Off
YC108	1	MOT1A	O	0/24 V DC (pulse)	DP paper feed motor drive pulse
Connected to the DP driver PWB	2	MOT2A	O	0/24 V DC (pulse)	DP paper feed motor drive pulse
	3	MOT1B	O	0/24 V DC (pulse)	DP paper feed motor drive pulse
	4	MOT2B	O	0/24 V DC (pulse)	DP paper feed motor drive pulse
	5	+24V4	O	24 V DC	24 V DC power source
	6	GND	-	-	Ground
YC109	1	+24V4	O	24 V DC	24 V DC power source
Connected to the DP driver PWB	2	GND	-	-	Ground

2-3-4 DP drive PWB

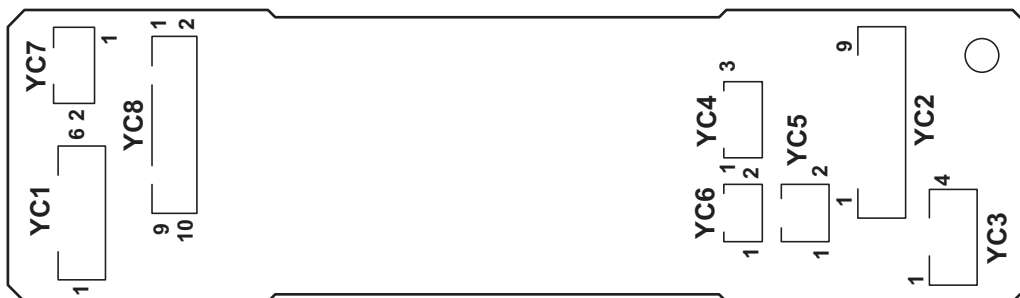

Figure 2-3-7 DP drive PWB silk-screen diagram

Connector	Pin	Signal	I/O	Voltage	Description
YC1 Connected to scanner PWB	1	MOT1A	I	0/24 V DC (pulse)	DPPFM drive control signal
	2	MOT2A	I	0/24 V DC (pulse)	DPPFM drive control signal
	3	MOT1B	I	0/24 V DC (pulse)	DPPFM drive control signal
	4	MOT2B	I	0/24 V DC (pulse)	DPPFM drive control signal
	5	+24V4	I	24 V DC	24 V DC power from MPWB
	6	GND	-	-	Ground
YC2 Connected to DP open/close sensor, DP original sensor and DP timing sensor	1	PILED	O	3.3 V DC	3.3 V DC power to DPOCS
	2	GND	-	-	Ground
	3	OPSWN	I	0/3.3 V DC	DPOCS: On/Off
	4	PILED	O	3.3 V DC	3.3 V DC power to DPOS
	5	GND	-	-	Ground
	6	ORGSWN	I	0/3.3 V DC	DPOS: On/Off
	7	PILED	O	3.3 V DC	3.3 V DC power to DPTS
	8	GND	-	-	Ground
	9	TIMSWN	I	0/3.3 V DC	DPTS: On/Off
YC3 Connected to DP paper feed motor	1	DPMOT1A	O	0/24 V DC (pulse)	DPPFM drive control signal
	2	DPMOT2A	O	0/24 V DC (pulse)	DPPFM drive control signal
	3	DPMOT1B	O	0/24 V DC (pulse)	DPPFM drive control signal
	4	DPMOT2B	O	0/24 V DC (pulse)	DPPFM drive control signal
YC4 Connected to DP pressure solenoid	1	+24V4	O	24 V DC	24 V DC power to DPPRSOL
	2	PRESOLN	O	0/24 V DC	DPPRSOL: ON (Press)/Off
	3	RELSOLN	O	0/24 V DC	DPPRSOL: On (Release)/Off
YC5 Connected to DP switch-back solenoid	1	+24V4	O	24 V DC	24 V DC power to DPSBSOL
	2	REVSOL	O	0/24 V DC	DPSBSOL: On/Off
YC6 Connected to DP paper feed clutch	1	+24V4	O	24 V DC	24 V DC power to DPPFCL
	2	FEEDCL	O	0/24 V DC	DPPFCL: On/Off
YC7 Connected to scanner PWB	1	+24V4	I	24 V DC	24 V DC power from SCPWB
	2	GND	-	-	Ground

Connector	Pin	Signal	I/O	Voltage	Description
YC8	1	+3.3V	I	3.3 V DC	3.3 V DC power from MPWB
Connected to scanner PWB	2	GND	-	-	Ground
	3	TIMSWN	O	0/3.3 V DC	DPTS: On/Off
	4	ORGSWN	O	0/3.3 V DC	DPOS: On/Off
	5	OPSWN	O	0/3.3 V DC	DPOCS: On/Off
	6	DPDETN	O	0/3.3 V DC	DP set signal
	7	RELSOLN	I	0/24 V DC	DPPRSOL: On (Release)/Off
	8	PRESOLN	I	0/24 V DC	DPPRSOL: ON (Press)/Off
	9	REVSOL	I	0/24 V DC	DPSBSOL: On/Off
	10	FEEDCL	I	0/24 V DC	DPPFCL: On/Off

2-4-1 Appendixes

(1) Wiring diagram

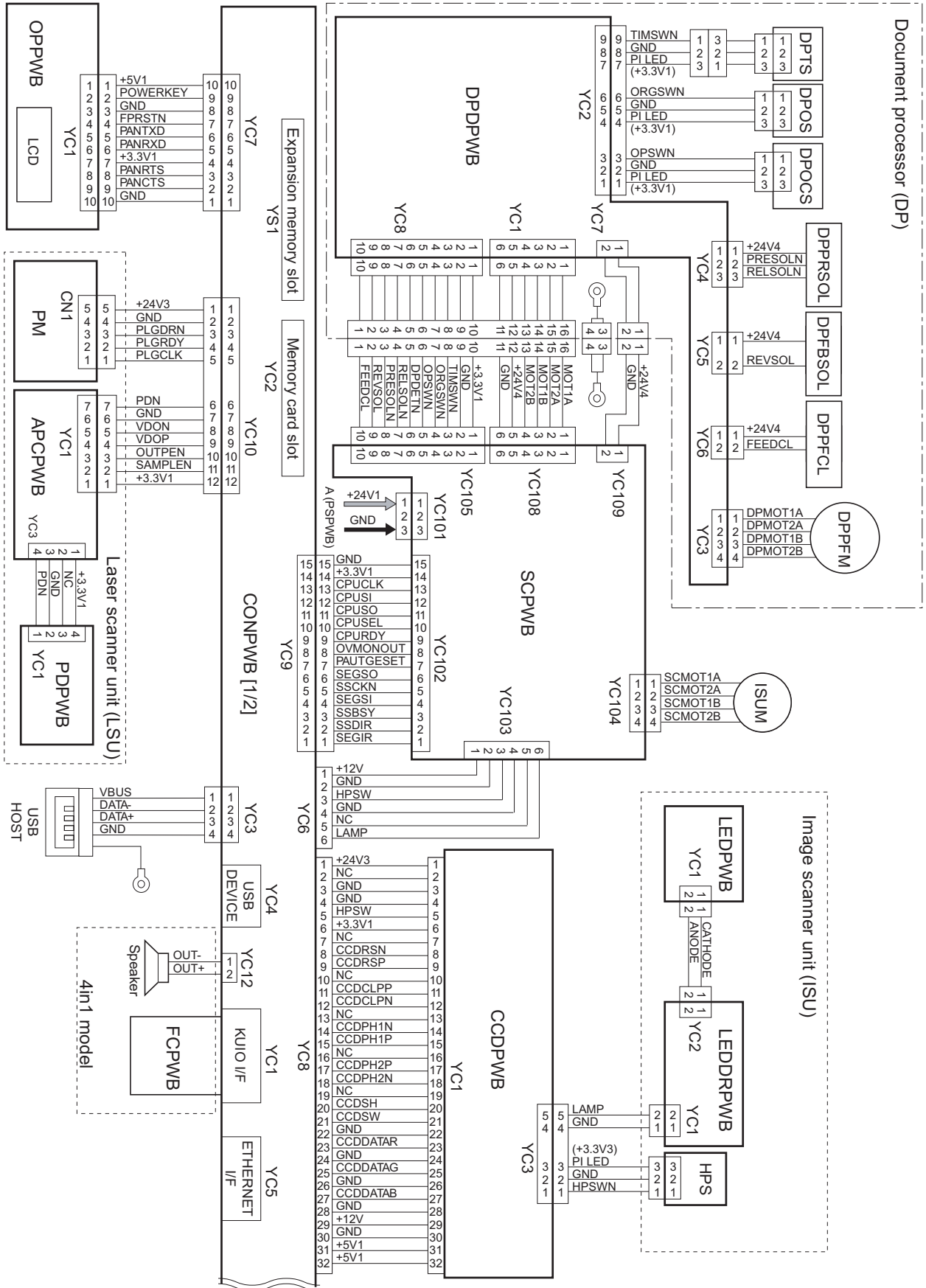

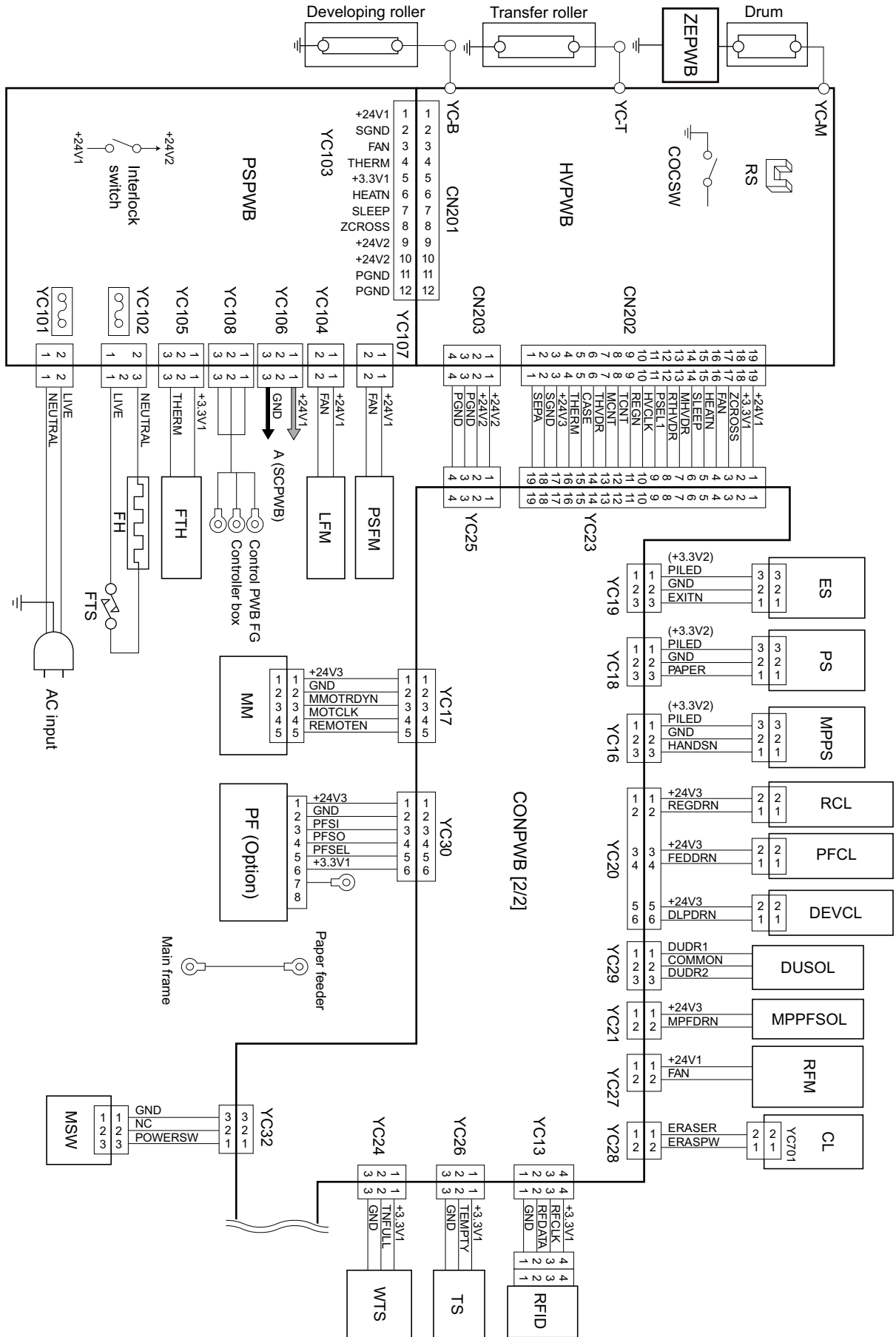

(2) Repetitive defects gauge

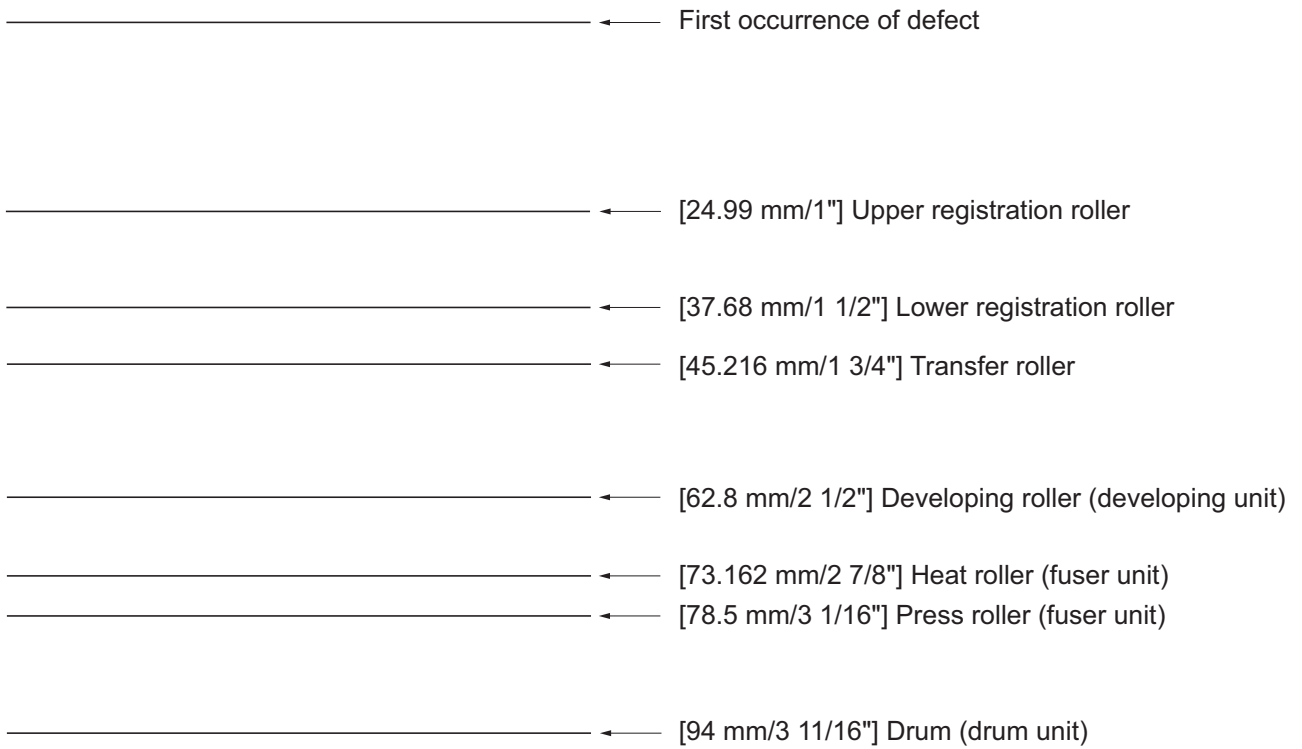

(3) Maintenance parts list

Maintenance part name		Part No.	Alternative part No.
Name used in service manual	Name used in parts list		
Maintenance kit (For 30ppm, 100,000page)	MK-1130/MAINTENANCE KIT (OPTION) DK-150 DV-132(U)	1702MJ0NL0	072MJ0NL
	MK-1132/MAINTENANCE KIT (OPTION) DK-150 DV-130(E)	1702MJ0KL0	072MJ0KL
	MK-1134/MAINTENANCE KIT (OPTION) DK-150 DV-134(AO)	1702MJ0AS0	072MJ0AS
Maintenance kit (For 35ppm, 100,000page)	MK-1140/MAINTENANCE KIT (OPTION) DK-150 DV-132(U)	1702ML0NL0	072ML0NL
	MK-1142/MAINTENANCE KIT (OPTION) DK-150 DV-130(E)	1702ML0KL0	072ML0KL
	MK-1144/MAINTENANCE KIT (OPTION) DK-150 DV-134(AO)	1702ML0AS0	072ML0AS

(4) Firmware Environment Commands

The printer maintains a number of printing parameters in its memory. These parameters may be changed permanently with the FRPO (Firmware RePrOgram) commands.

This section provides information on how to use the FRPO command and its parameters using examples.

Using FRPO Commands for Reprogramming Firmware

The current settings of the FRPO parameters are listed as optional values on the service status page.

Note: Before changing any FRPO parameter, print out a service status page, so you will know the parameter values before the changes are made. To return FRPO parameters to their factory default values, send the FRPO INIT (FRPO-INITialize) command.(!R! FRPO INIT; EXIT;)

The FRPO command is sent to the printer in the following sequence:

!R! FRPO parameter, value; EXIT;

Example: Changing emulation mode to PC-PR201/65A

!R! FRPO P1, 11; EXIT;

FRPO Parameters

Environment	Parameter	Values	Factory setting
Top margin	A1	Integer value in inches	0
	A2	Fraction value in 1/100 inches	0
Left margin	A3	Integer value in inches	0
	A4	Fraction value in 1/100 inches	0
Page length	A5	Integer value in inches	13
	A6	Fraction value in 1/100 inches	61
Page width	A7	Integer value in inches	13
	A8	Fraction value in 1/100 inches	61
Default pattern resolution	B8	0: 300 dpi 1: 600 dpi	0
Copy count	C0	Number of copies to print:1-999	1
Page orientation	C1	0: Portrait 1: Landscape	0
Default font No. *	C2	Middle two digits of power-up font	0
	C3	Last two digits of power-up font	0
	C5	First two digits of power-up font	0
PCL font switch	C8	0:HP compatibility mode (Characters higher than 127 are not printed.) 32:Conventional mode (Characters higher than 127 are printed. Supported symbol sets: ISO-60 Norway [00D], ISO-15 Italian [00I], ISO-11 Sweden [00S], ISO-6 ASCII [00U], ISO-4 U.K. [01E], ISO-69 France [01F], ISO-21 Germany [01G], ISO-17 Spain [02S], Symbol [19M] ^a)	0
Total host buffer size	H8	0 to 99 in units of the size defined by FRPO S5	5
Form feed time-out value	H9	Value in units of 5 seconds (0 to 99).	6
KIR mode	N0	0: Off 2: On	2

Environment	Parameter	Values	Factory setting
Duplex binding	N4	0: Off 1: Long edge 2: Short edge	0
Sleep timer time-out time	N5	1 to 240 minutes [0: Off]	15
Ecoprint level	N6	0:Off 2:On	0
Printing resolution	N8	0: 300dpi 1: 600dpi 3: 1200dpi	1
Default emulation mode	P1	0: Line Printer 1: IBM Proprinter X24E 2: Diablo 630 5: Epson LQ-850 6: PCL 6 9: KPDL	9 (U.S.A) or 6 (Euro and other)
Carriage-return action *	P2	0: Ignores 0x0d 1: Carriage-return 2: Carriage-return+linefeed	1
Linefeed action *	P3	0: Ignores 0x0d 1: Linefeed 2: Linefeed+carriage-return	1
Automatic emulation sensing (For KPDL3)	P4	0:AES disabled 1:AES enabled	1 (U.S.A) or 0 (Euro and other)
Alternative emulation (For KPDL3)	P5	Same as the P1 values except that 9 is ignored.	6
Automatic emulation switching trigger (For KPDL3)	P7	0: Page eject commands 1: None 2: Page eject and Prescribe EXIT 3: Prescribe EXIT 4: Formfeed (^L) 6: Page eject, Prescribe EXIT and formfeed 10: Page eject commands; if AES fails, resolves to KPDL	11 (U.S.A) or 10 (Euro and other)
Command recognition character	P9	ASCII code of 33 to 126	82 (R)

Environment	Parameter	Values	Factory setting
Default paper size	R2	0: Size of the default paper cassette (See R4.) 1: Monarch (3-7/8 × 7-1/2 inches) 2: Business (4-1/8 × 9-1/2 inches) 3: International DL (11 × 22 cm) 4: International C5 (16.2 × 22.9 cm) 5: Executive (7-1/4 × 10-1/2 inches) 6: US Letter (8-1/2 × 11 inches) 7: US Legal (8-1/2 × 14 inches) 8: A4 (21.0 × 29.7 cm) 9: B5 (18.2 × 25.7 cm) 13: A5 14: A6 (10.5 × 14.8 cm) 15: B6 (12.8 × 18.2 cm) 16: Commercial #9 (3-7/8 × 8-7/8 inches) 17: Commercial #6 (3-5/8 × 6-1/2 inches) 18: B5 (17.6 × 25 cm) 19: Custom (11.7 × 17.7 inches)f 20: B4→A4 reduces 21: A3→A4 reduces 22: A4→A4 98% reduces 23: Stock form→A4 reduces 31: Hagaki (10 × 14.8 cm)f 32: Ofuku-Hagaki (14.8 × 20 cm)f 33: Officio II 40: 16K 42: 21.6 x 34 cm 50: Statement 51: Folio 52: Youkei 2 53: Youkei 4	0
Default cassette	R4	0: Multi-purpose tray 1 1: Cassette 1 2: Cassette 2 3: Cassette 3	1
MP tray paper size	R7	Same as the R2 values except: 0	6 (U.S.A) or 8 (Euro and other)
Daisywheel data length	R8	7:7-bit 8:8-bit	7
A4/letter equation	S4	0:Off 1:On	1
Host buffer size	S5	0: 10kB (x H8) 1: 100kB (x H8) 2: 1024kB (x H8)	1
RAM disk size	S6	1 to 1024 MB	400

Environment	Parameter	Values	Factory setting
RAM disk mode	S7	0: Off 1: On	0
Cassette 1 paper size	T1	4: International C5 (16.2 × 22.9 cm) 5: Executive (7-1/4 × 10-1/2 inches) 6: US Letter (8-1/2 × 11 inches) 7: US Legal (8-1/2 × 14 inches) 8: A4 (21.0 × 29.7 cm) 9: B5 (18.2 × 25.7 cm) 13: A5 14: A6 (10.5 × 14.8 cm) 18: B5 (17.6 × 25 cm) 19: Custom (11.7 × 17.7 inches)f 33: Officio II 40: 16K 42:216x340 50: Statement 51: Folio	6 (U.S.A) or 8 (Euro and other)
Cassette 1 paper size	T2	4: International C5 (16.2 × 22.9 cm) 5: Executive (7-1/4 × 10-1/2 inches) 6: US Letter (8-1/2 × 11 inches) 7: US Legal (8-1/2 × 14 inches) 8: A4 (21.0 × 29.7 cm) 9: B5 (18.2 × 25.7 cm) 13: A5 18: B5 (17.6 × 25 cm) 19: Custom (11.7 × 17.7 inches)f 33: Officio II 40: 16K 42:216x340 51: Folio	6 (U.S.A) or 8 (Euro and other)
Cassette 1 paper size	T3	Same as above.	6 (U.S.A) or 8 (Euro and other)
Wide A4	T6	0:Off 1:On	0
Line spacing *	U0	Lines per inch (integer value)	6
Line spacing *	U1	Lines per inch (fraction value)	0
Character spacing *	U2	Characters per inch (integer value)	10
Character spacing *	U3	Characters per inch (fraction value)	0

Environment	Parameter	Values	Factory setting
Country code	U6	0: US-ASCII 1: France 2: Germany 3: UK 4: Denmark 5: Sweden 6: Italy 7: Spain 8: Japan 9: US Legal 10: IBM PC-850 (Multilingual) 11: IBM PC-860 (Portuguese) 12: IBM PC-863 (Canadian French) 13: IBM PC-865 (Norwegian) 14: Norway 15: Denmark 2 16: Spain 2 17: Latin America 21: US ASCII (U7=50 SET) 77: HP Roman-8 (U7=52 SET)	41
Code set at power up in daisywheel emulation	U7	0: Same as the default emulation mode (P1) 1: IBM 6: IBM PC-8 50: US ASCII (U6=21 SET) 52: HP Roman-8 (U6=77 SET)	53
Font pitch for fixed pitch scalable font	U8	Integer value in cpi: 0 – 99	10
	U9	Fraction value in 1/100 cpi: 0 – 99	0
Font height for the default scalable font *	V0	Integer value in 100 points: 0–9	0
	V1	Integer value in points: 0–99	12
	V2	Fraction value in 1/100 points: 0, 25, 50, 75	0
Default scalable font *	V3	Name of typeface of up to 32 characters, enclosed with single or double quotation marks	Courier
Default weight (courier and letter Gothic)	V9	0: Courier = darkness Letter Gothic = darkness 1: Courier = regular letter Gothic = darkness 4: Courier = darkness Letter Gothic = regular 5: Courier = regular letter Gothic = regular	5

Environment	Parameter	Values	Factory setting			
Paper type for the MP tray	X0	1: Plain 1	1			
		2: Transparency				
		3: Preprinted				
		4: Label				
		5: Bond				
		6: Recycle				
		7: Vellum				
		9: Letterhead				
		10: Color				
		11: Prepunched				
		12: Envelope				
		13: Cardstock				
		16: Thick				
		17: High Quality				
		21: Custom1				
		22: Custom2				
		23: Custom3				
		24: Custom4				
		25: Custom5				
		26: Custom6				
		27: Custom7				
		28: Custom8				
		Paper type for paper cassettes 1		X1	1: Plain	1
					3: Preprinted	
					5: Bond	
					6: Recycled	
					9: Letterhead	
					10: Color	
11: Prepunched						
17: High Quality						
21: Custom1						
22: Custom2						
23: Custom3						
24: Custom4						
25: Custom5						
26: Custom6						
27: Custom7						
28: Custom8						

Environment	Parameter	Values	Factory setting
Paper type for paper cassettes 2 to 4	X2	1: Plain	1
	X3	3: Preprinted	
		5: Bond	
		6: Recycled	
		9: Letterhead	
		10: Color	
		11: Prepunched	
		17: High Quality	
		21: Custom1	
		22: Custom2	
		23: Custom3	
		24: Custom4	
		25: Custom5	
		26: Custom6	
27: Custom7			
28: Custom8			
PCL paper source	X9	0: Performs paper selection depending on media type. 1: Performs paper selection depending on paper sources.	0
Automatic continue for 'Press GO'	Y0	0:Off 1:On	0
Automatic continue timer	Y1	number from 0 to 99 in increments of 5 seconds	6 (30secs)

Environment	Parameter	Values	Factory setting
Error message for device error	Y3	0:Not Detect 1:Detect	127
Duplex operation for specified paper type (Prepunched, Preprinted and Letter-head)	Y4	0:Off 1:On	0
Default operation for PDF direct printing	Y5	0: Enlarges or reduces the image to fit in the current paper size. Loads paper from the current paper cassette. 1: Through the image. Loads paper which is the same size as the image. 2: Enlarges or reduces the image to fit in the current paper size. Loads Letter, A4 size paper depending on the image size. 3: Through the image. Loads Letter, A4 size paper depending on the image size. 8: Through the image. Loads paper from the current paper cassette. 9: Through the image. Loads Letter, A4 size paper depending on the image size. 10: Enlarges or reduces the image to fit in the current paper size. Loads Letter, A4 size paper depending on the imagesize.	0

- a. Characters higher than 127 are printed regardless of the C8 value. However, setting C8 to 0 does not print character code 160.

*. Ignored in some emulation modes.

INSTALLATION GUIDE FOR PAPER FEEDER

PF-120

安装手册
 インストールガイド
 Installation Guide
 Guide d'installation
 Guía de instalación
 Installationsanleitung
 Guida all'installazione

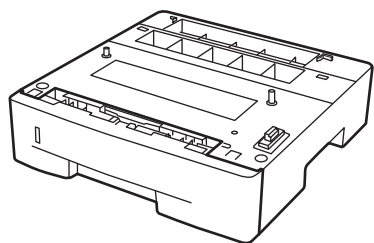

[120 V specifications only]

NOTICE

This accessory is for use only with the following Applicant's Listed Machine. Refer to the supplied guide to install the accessory in the field.

Machine: FS-1030MFP, FS-1130MFP, FS-1035MFP, FS-1135MFP

PF-120的安装
 PF-120の設置
 Installation of PF-120
 Installation de PF-120

Instalación de PF-120
 Installation von PF-120
 Installazione di PF-120

1

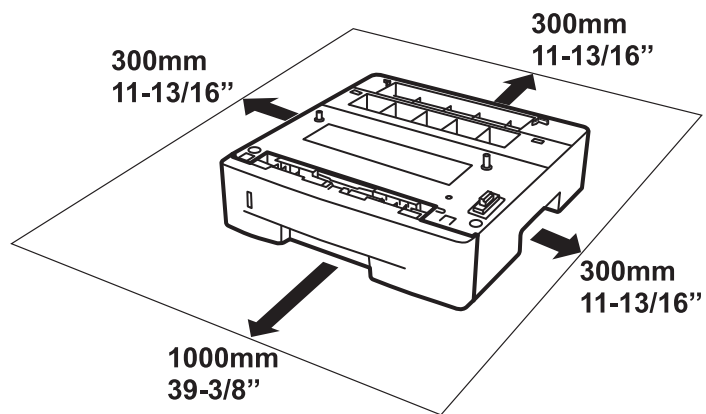

2

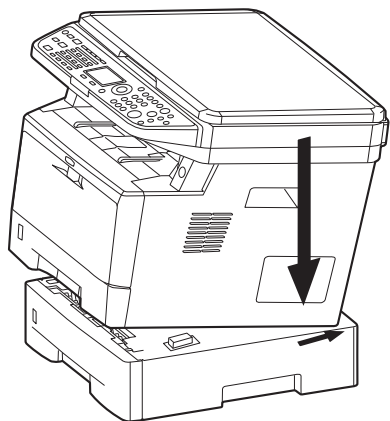

3

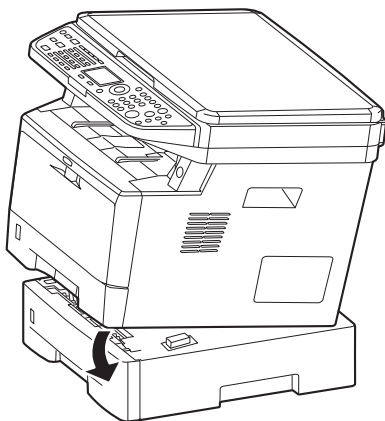

4

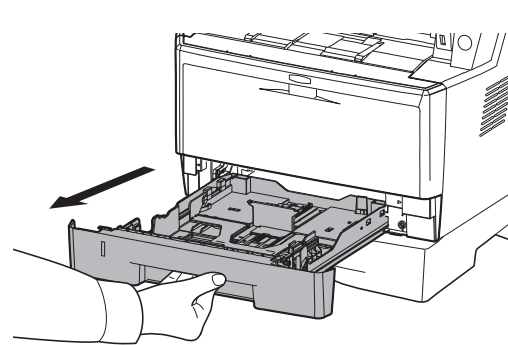

5

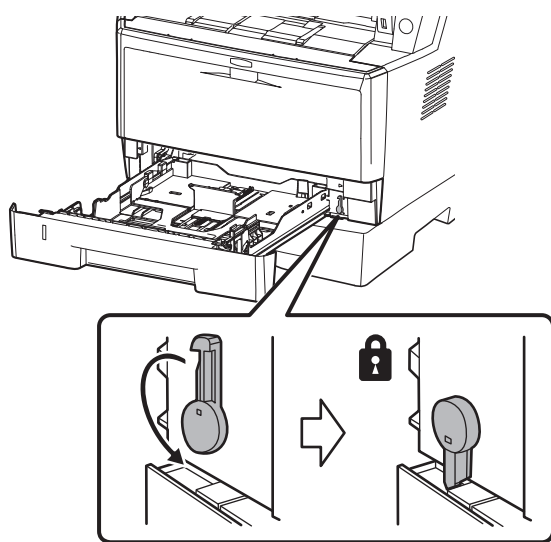

6

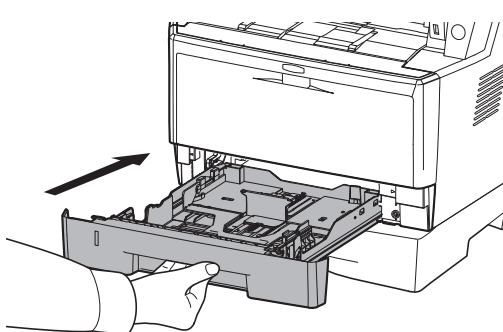

7

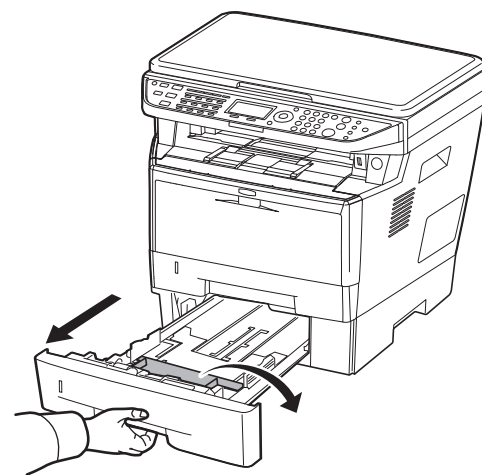

纸张大小的调整
用紙サイズの調整

8

Adjustment of paper size

Ajustement de format papier

Ajuste del tamaño del papel

Justage des Papierformats

Registrazione del formato carta

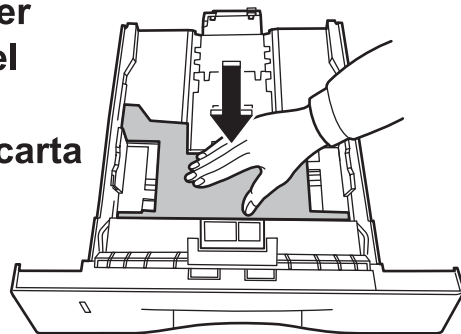

9

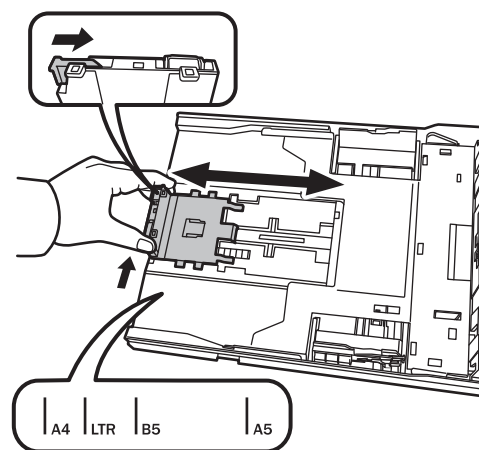

10

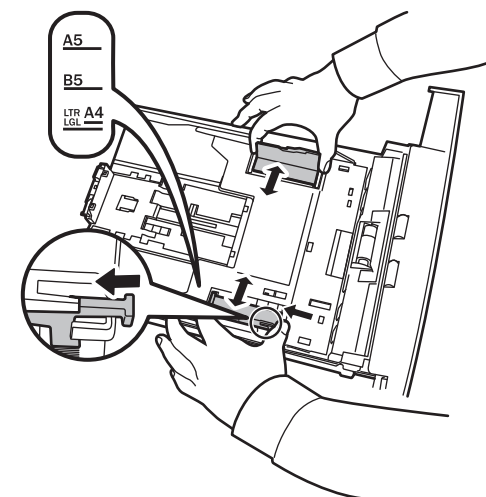

Folio / Oficio II

(1)

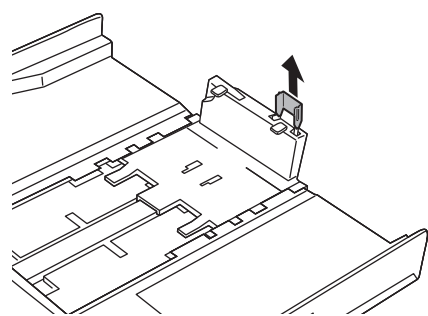

(2)

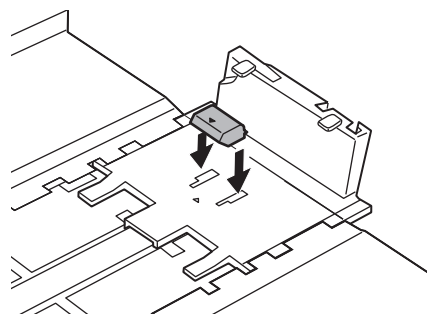

(3)

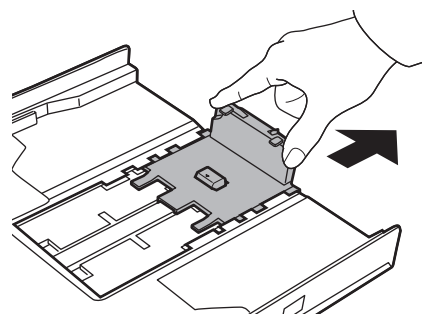

Legal

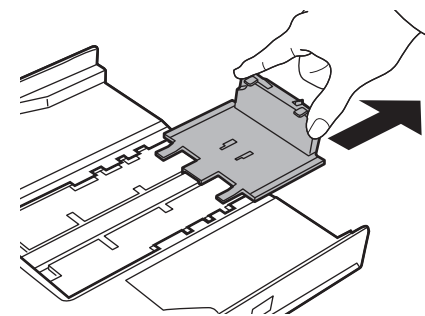

装紙

用紙のセット

Loading paper

Papier de chargement

Papel del cargamento

Ladenpapier

Carta da caricamento

11

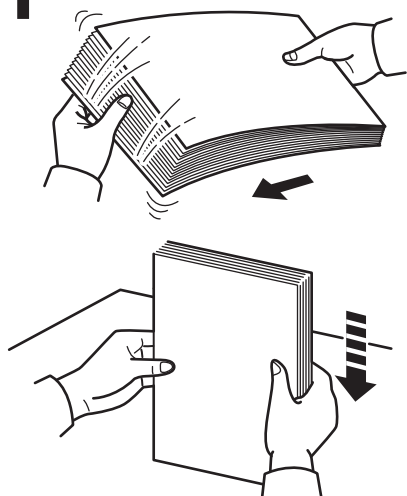

12

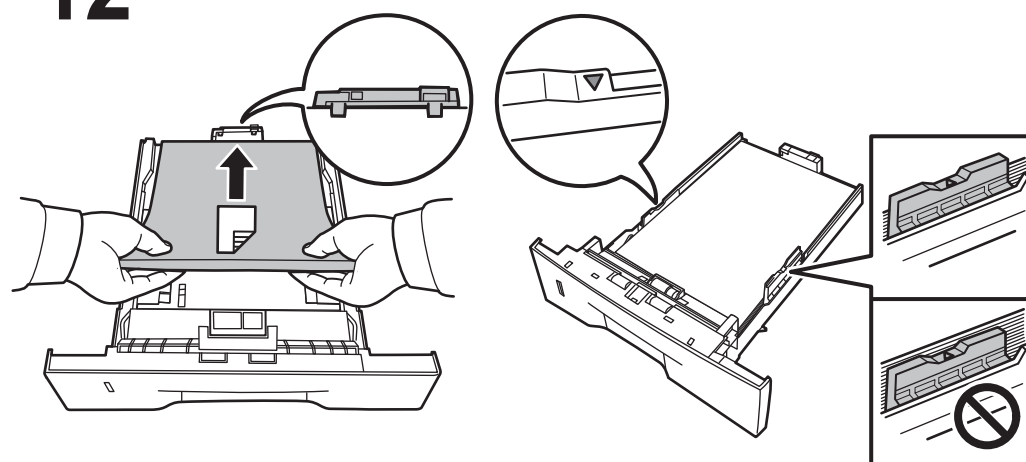

13

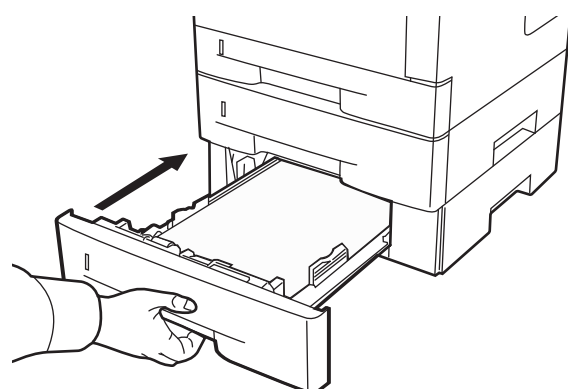

取出卡紙

紙づまりの処理

Removing Paper Jams

Solution pour les bouchages papier

Eliminación de los atascos de papel

Entfernen von Papierstaus

Rimozione degli inceppamenti carta

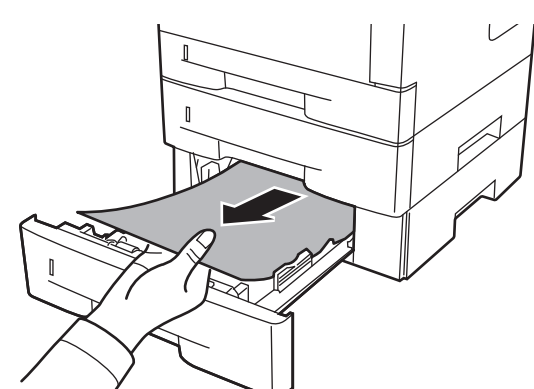

关于纸张的规格，请参阅机器的操作手册。

用紙の仕様については、本体使用説明書を参照してください。

For paper specification, refer to the machine's Operation Guide.

Avec les spécifications de papier, référez-vous au guide de l'opération de machine.

Para la especificación de papel, refiera a la guía de la operación de máquina.

Für Papierspezifikation beziehen Sie sich den auf Führer Rechneroperation.

Per la specifica di carta, riferiscasi alla guida di funzionamento della macchina.

KYOCERA MITA EUROPE B.V.

Bloemlaan 4, 2132 NP Hoofddorp,
The Netherlands
Phone: +31.20.654.0000
Home page: <http://www.kyoceramita-europe.com>
Email: info@kyoceramita-europe.com

KYOCERA MITA NEDERLAND B.V.
Beechavenue 25, 1119RA Schiphol-Rijk
The Netherlands
Phone: +31.20.58.77.200

KYOCERA MITA (UK) LTD
8 Beacontree Plaza
Gillette Way Reading Berks RG2 0BS,
U.K.
Phone: +44.1189.311.500

KYOCERA MITA ITALIA S.p.A.
Via G. Verdi, 89 / 91, 20063 Cernusco s/N
Milano, Italy
Phone: +39.02.92179.1

S.A. KYOCERA MITA BELGIUM N.V.
Sint-Martinusweg 199-201, 1930 Zaventem,
Belgium
Phone: +32.2.720.9270

KYOCERA MITA FRANCE S.A.
Espace Technologique de St Aubin
Route de l' Orme
91195 Gif-sur-Yvette CEDEX, France
Phone: +33.1.6985.2600

KYOCERA MITA ESPAÑA S.A.
Edificio Kyocera, Avda de Manacor No. 2,
28290 Las Matas (Madrid),
Spain
Phone: +34.91.631.8392

KYOCERA MITA FINLAND OY
Atomitie 5C, 00370 Helsinki,
Finland
Phone: +358.9.4780.5200

KYOCERA MITA (SCHWEIZ)
Hohlstrasse 614, 8048 Zürich
Switzerland
Phone: +41.44.908.4949

KYOCERA MITA DEUTSCHLAND GMBH
Otto-Hahn-Str. 12 D-40670 Meerbusch,
Germany
Phone: +49.2159.918.0

KYOCERA MITA GMBH AUSTRIA
Eduard-Kittenberger-Gasse 95,
1230 Wien,
Austria
Phone: +43.1.86338

KYOCERA MITA SVENSKA AB
Esbogatan 16B 164 75 Kista,
Sweden
Phone: +46.8.546.55000

KYOCERA MITA NORGE
Postboks 150 Oppsal, NO 0619 Oslo
Olaf Helsetsvetvei 6, NO 0694 Oslo,
Norway
Phone: +47.22.62.73.00

KYOCERA MITA DANMARK A/S
Ejby Industrivej 60, DK-2600 Glostrup,
Denmark
Phone: +45.7022.3880

KYOCERA MITA PORTUGAL LDA.
Rua do Centro Cultural, 41 (Alvalade) 1700-106 Lisboa,
Portugal
Phone: +351.21.843.6780

KYOCERA MITA SOUTH AFRICA (PTY) LTD.
49 Kyalami Boulevard,
Kyalami Business Park Midrand,
South Africa
Phone: +27.(0)11.540.2600

KYOCERA MITA AMERICA, INC.

Headquarters:
225 Sand Road,
Fairfield, New Jersey 07004-0008,
U.S.A.
Phone: (973) 808-8444

KYOCERA MITA AUSTRALIA PTY. LTD.
Level 3, 6-10 Talavera Road, North Ryde,
N.S.W. 2113 Australia
Phone: (02) 9888-9999

KYOCERA MITA NEW ZEALAND LTD.
1-3 Parkhead Place, Albany
P.O. Box 302 125 NHPC, Auckland,
New Zealand
Phone: (09) 415-4517

KYOCERA MITA Asia Limited

16/F., Mita Centre,
552-566, Castle Peak Road,
Tsuen Wan, New Territories, Hong Kong
Phone: (852)-2610-2181

KYOCERA MITA Corporation

2-28, 1-chome, Tamatsukuri, Chuo-ku
Osaka 540-8585, Japan
Phone: (06) 6764-3555
<http://www.kyoceramita.com>

©2011 KYOCERA MITA Corporation

 **KYOCERA** is a trademark of Kyocera Corporation

KYOCERA MITA AMERICA, INC.

Headquarters:

225 Sand Road,
Fairfield, New Jersey 07004-0008
TEL : (973) 808-8444
FAX : (973) 882-6000

New York Branch:

30-30 47th Avenue
Long Island City, NY 11101
TEL : (718) 289-2500
FAX : (718) 289-2501

Northeastern Region:

225 Sand Road,
Fairfield, New Jersey 07004-0008
TEL : (973) 808-8444
FAX : (973) 882-4401

Midwestern Region:

201 Hansen Court Suite 119
Wood Dale, Illinois 60191
TEL : (630) 238-9982
FAX : (630) 238-9487

Western Region:

14101 Alton Parkway,
Irvine, California 92618-7006
TEL : (949) 457-9000
FAX : (949) 457-9119

Southeastern Region:

3100 Breckinridge Blvd. NW Building 100,
Suite 105 Duluth, Georgia 30096
TEL : (770) 729-9786
FAX : (770) 729-9873

Southwestern Region:

2825 West Story Road,
Irving, Texas 75038-5299
TEL : (972) 550-8987
FAX : (972) 570-4704

National Operation Center & National Training Center:

2825 West Story Road,
Irving, Texas 75038-5299
TEL : (972) 659-0055
FAX : (972) 570-5816

Latin America Division:

8240 N.W. 52nd. Terrace Dawson Building,
Suite 108 Miami, Florida 33166
TEL : (305) 421-6640
FAX : (305) 421-6666

KYOCERA MITA CANADA, LTD.

6120 Kestrel Road, Mississauga,
Ontario L5T 1S8, Canada
TEL : (905) 670-4425
FAX : (905) 670-8116

KYOCERA MITA MEXICO, S.A. DE C.V.

Av. 16 de Septiembre #407
Col. Santa Inés,
Azcapotzalco México,
D.F. 02130, México
TEL : (55) 5383-2741
FAX : (55) 5383-7804

KYOCERA MITA Brazil Ltda.

Av. Tambore, 1180 Mob.B-09 CEP 06460-000
Tambore-Barveri-SP,
Brazil
TEL : (55) 11-4195-8496
FAX : (55) 11-4195-6167

KYOCERA MITA Asia Limited

16/F., Mita Centre,
552-566, Castle Peak Road,
Tsuen Wan, New Territories, Hong Kong
Phone: (852)-2610-2181

KYOCERA MITA (Thailand) Corp., Ltd.

335 Ratchadapisek Road, Bangsue,
Bangkok, 10800, Thailand
Phone: (66)-2-586-0333

KYOCERA MITA Singapore Pte Ltd.

121 Genting Lane, 3rd Level,
Singapore 349572
Phone: (65)-6741-8733

KYOCERA MITA Hong Kong Limited

16/F., Mita Centre,
552-566, Castle Peak Road,
Tsuen Wan, New Territories,
Hong Kong
Phone: (852)-2429-7422

KYOCERA MITA Taiwan Corporation

6F., No.37, Sec. 3, Minquan E. Rd.,
Zhongshan Dist., Taipei 104, Taiwan R.O.C.
Phone: (886)-2-2507-6709

KYOCERA MITA Korea Co., Ltd.

18F, Kangnam bldg, 1321-1,
Seocho-Dong, Seocho-Gu, Seoul, Korea
Phone: (822)-6933-4050

KYOCERA MITA India Private Limited

First Floor, ORCHID CENTRE
Sector-53, Golf Course Road, Gurgaon 122
002, India
Phone: (91)-0124-4671000

©2011 KYOCERA MITA Corporation

 is a trademark of Kyocera Corporation